



ENGINEERING DESIGN MANUAL

EGLIN AFB, FLORIDA



March 2025

This document serves as a fundamental document guiding the design and construction of civil engineer projects on Eglin Air Force Base. The purpose of this document is to ensure construction agents and contractors know the minimum standards for designing and constructing facility projects on Eglin. If there is a difference between Eglin-specific standards and higher headquarters standards (eg, National Electric Code, Air Force Instructions, Department of Defense Directives, etc), the more restrictive standard will take precedence. Though the information contained in this document is expansive, it is not meant to replace good engineering judgment, which will be determined by the 96th Civil Engineer Group Facility Project or Capital Project Project Manager.

SUMMARY OF CHANGES

This document has been substantially revised and must be reviewed thoroughly. A significant number of administrative changes were made throughout this document, including the renumbering of several paragraphs. Many references were added and updated to remain in compliance with various codes. The requirement for all project reviewers to submit their comments into Dr Checks was added. Letters from Headquarters, Air Force Civil Engineer Center, were added which state specific infrastructure systems to be used on Eglin Air Force Base. Two appendices have had extensive rewrites. One is Appendix 12, *Eglin Specific Fire Suppression Requirements*, and the other is Appendix 14, *Eglin Specific Electrical / Electronic Requirements (Including Fire Alarms)*.

ERIC B. RUSHING, PE
Chief, Engineering Division
96th Civil Engineer Group

Table of Contents

Chapter 1 - General Instructions	5
Chapter 2 - Specifications	15
Chapter 3 - Site Development	19
Chapter 4 - Survey and Mapping	32
Chapter 5 - Geotechnical	42
Chapter 6 - Landscaping, Irrigation, Planting and Turfing	63
Chapter 7 - Water, Wastewater and Environmental Protection	68
Chapter 8 - Architecture	73
Chapter 9 - Structural	88
Chapter 10 - Plumbing	96
Chapter 11 - Heating, Ventilating and Air Conditioning	102
Chapter 12 - Fire Suppression System	109
Chapter 13 - Other Mechanical Systems and Equipment	113
Chapter 14 - Electrical and Electronic Systems	120
Chapter 15 - Corrosion Control and Cathodic Protection Systems	137
Chapter 16 - Telecommunications	152
Chapter 17 - Cost Estimates	153
Chapter 18 - Antiterrorism/Force Protection (AT/FP)	174
Appendix	179
Appendix 1 – Eglin Specific General Requirements	180
Appendix 2 – Eglin Specific Specification Requirements	180
Appendix 3 – Eglin Specific Site Development Requirements	180
Appendix 4 – Eglin Specific Survey and Mapping Requirements	181
Appendix 5 – Eglin Specific Geotechnical Requirements	182
Appendix 6 – Eglin Specific Landscaping, Irrigation, Planting and Turfing Requirements	182

Appendix 7 – Eglin Specific Water, Wastewater and Environmental Protection Requirements	183
Appendix 8 – Eglin Specific Architectural Requirements	183
Appendix 9 – Eglin Specific Structural Requirements	194
Appendix 10 – Eglin Specific Plumbing Requirements	194
Appendix 11 – Eglin Specific HVAC Requirements, Including DDC	195
Appendix 12 – Eglin Specific Fire Suppression Requirements	207
Appendix 13 – Eglin Specific Other Mechanical Systems and Equipment Requirements	216
Appendix 14 – Eglin Specific Electrical / Electronic Requirements (Including Fire Alarms)	216
Appendix 15 – Eglin Specific Corrosion Control and Cathodic Protection Requirements	246
Appendix 16 – Eglin Specific Telecommunications Requirements	246
Appendix 17 – Eglin Specific Cost Estimate Requirements	246
Appendix 18 – Eglin Specific Antiterrorism / Force Protection	246
Appendix 19 – Eglin Energy Conservation Requirements	255
Appendix 20 – Eglin Specific Termiticide Information	257
Appendix 21 – Eglin Specific Airfield Criteria	258

Chapter 1 - General Instructions

1.1 GENERAL

1.1.1 Purpose

This Eglin Air Force base Design Manual prescribes standard procedures and instructions to accomplish the required design, drawings, specifications, project definition narrative, design analysis, cost estimates, and related support tasks for Military projects. This manual is written with the purpose of assisting designers with a consistent logical approach to performing design and developing design related documents. The organization of this manual is such that design procedures at various submittal stages are presented at the beginning of each Chapter with technical requirements presented last. Eglin specific technical requirements are presented in the appendices.

1.1.2 Statement of Work (SOW)

- (a) The Statement of Work (SOW) will provide project specific execution criteria in conformance with the current version of this Eglin Air Force Base (AFB) Design Manual.
- (b) A SOW will be issued to the Architect-Engineer (A-E) prior to conduct of the pre-design conference. A-E attendance at the pre-design conference is considered essential in ensuring an understanding by the A-E of project, user, and installation requirements.
- (c) As issued, the SOW will take precedence over the standard procedures and instructions in this manual. The A-E shall document any conflicts between this manual and the SOW in writing and bring them to the immediate attention of the Contracting Officer (CO).
- (d) The A-E shall furnish sufficient technical, supervisory, and administrative personnel to ensure satisfactory accomplishment of the work specified in the SOW, including accomplishment of work by agreed milestone dates and progress schedule. Additionally, the A-E shall furnish all services, materials, supplies, equipment, investigations, studies, and travel required in connection with the SOW.
- (e) The A-E shall accept directions only from the Contracting Officer (CO) or the Contracting Officer's Representative (COR). Requests or desires of the users or using agency made directly to the A-E shall be immediately brought to the CO's attention. Any changes to the project scope or other provisions of the SOW must be authorized in writing by the CO.
- (f) A-E Actions required prior to SOW approval.
 - (1) The A-E shall use those individuals designated in their SF330 submission. If any of these individuals are changed, the CO shall be notified in writing. The SF330 shall be resubmitted with these personnel changes and those person's individual qualifications. Government approval for these changes is required.
 - (2) Needs List. Throughout the life of the project, the A-E shall furnish a "needs" list every two weeks until all open issues are resolved. The needs list

shall also be included in each formal submittal. The needs list shall be an itemized list of design data required by the A-E to advance the design in a timely manner. This list will be maintained on a continuous basis with satisfied action items checked off and new action items added as required. Action items in the needs list will include a sequence number, description of action item, name of individual or agency responsible for satisfying the action item, and remarks.

- (3) Site investigations must be sufficiently thorough to ensure that design details are compatible with the project site. Siting or orientation shall not be changed without approval of Eglin AFB. At the Final Design submittal stage, the A-E shall make a plan-in-hand site visit to ensure that the final design accurately reflects existing site conditions. Any changes in site conditions that were made by the government during the design period shall be annotated and brought to the attention of the CO for direction.
- (4) Should the project cost estimate exceed the funding limitation, the A-E shall make recommendations for reducing the project scope and/or identifying optional bid items of work. Upon receiving written approval from the CO, the A-E shall modify the contract drawings and specifications to incorporate all changes as necessary to reduce the base bid cost estimate below the funding limitation. If any criteria provided to the A-E during design prevents him from meeting the cost limitations, the A-E shall notify the CO immediately. The A-E shall list the specific criteria and explain the negative impact on the design cost.
- (5) The A-E shall not correspond either in writing or verbally, with any prospective bidder during the advertisement period. All requests for information (RFI) from a prospective bidder shall be submitted in writing to the CO.
- (6) During the construction period the A-E shall furnish advice as may be requested. During the construction period, limited construction phase services may be required. If construction phase services are required, appropriate modifications to the contract will be made.
- (7) The A-E shall review and approve construction contractor product submittals before submittals to the government as a part of their fees. These submittals will comply with the requirements outlined in the plans and specifications.

1.1.3 Acronyms and Abbreviations

Acronyms and abbreviations are generally written out on first use in each chapter.

1.1.4 Discipline Coordination

- (a) Individual design team members are responsible for coordinating their efforts with those of other design team disciplines.
- (b) The A-E shall prepare a written record of each site visit, meeting, or conference, either telephonic or in person, and shall furnish this record within five working days

to the CO with copies to all parties involved. The written record shall include the subject, the names of the participants, an outline discussion, and the recommendations or conclusions reached.

- (c) The A-E shall include a Design Analysis containing government review comments and their resolutions.

1.2 APPLICABLE PUBLICATIONS

Applicable publications are listed in various chapters of this manual. The most recent editions of the cited publications at the start of Concept Design for D-B-B or Interim Design for D-B will be referenced and incorporated (as appropriate) in work prescribed by this manual. The publications cited in individual chapters, but referred to thereafter by basic designation only, form a part of this manual. The publications are supplemented by the Unified Facilities Guide Specifications (UFGS) to form design criteria. Unless specifically stated otherwise in this manual or the SOW, the designer shall be responsible for obtaining all publications applicable to the design of the project including, but not limited to, the cited publications. The recommended source for many publications is the Whole Building Design Guide (WBDG) which contains United States Army Corps of Engineers (USACE) technical Manuals (TM), Unified Facilities Criteria (UFC), Engineering Regulations (ER), Engineering Technical Letters (ETL), American Society of Heating Refrigerating and Air-Conditioning (ASHRAE), Illumination Engineering Society (IES), and industry and other government standards. The WBDG is at the following web site:

<http://www.wbdg.org>

For A-E projects, additional project specific customer and user requirements or additional publications and references may be listed in the SOW.

1.3 INSTRUCTIONS

1.3.1 Pre-Design Conference

The CO shall request that the designers attend a pre-design conference at the project site and participate in discussions prior to the preparation of a fee proposal and negotiations for a project designed by an A-E. During these discussions, all aspects of the required effort, which shall affect the designer's effort, will be addressed.

- (a) A-E Design. The A-E will be responsible for recording minutes from the pre-design conference. The A-E designer shall be furnished a draft SOW which will contain project specific design criteria and instructions. After the pre-design conference, the A-E designer shall receive a request to furnish a fee proposal for accomplishing the work agreed upon during the conference.

1.3.2 Charrette

Charrette conduct will be determined during the pre-design conference. The requirements will be specified in the SOW.

1.3.3 Life, Health, and Safety Standards

The most recent version of the Unified Facilities Criteria (UFC) will be used as the basis of design of facilities unless specifically exempted by the customer and documented. In addition, the most recent version of NFPA 101 Life Safety Code and other NFPA Codes shall be incorporated into the design as appropriate. UFC 1-200-

01 will be used by all designers as the basis of determination of code requirements (changes mandated in use of codes in UFC 1-200-01 will be adjusted based on the use of the most recent UFC and NFPA codes until UFC 1-200-01 is updated). The facilities, systems, and equipment design standards of the Occupational Safety and Health Act, Code of Federal Regulations, Title 29, Chapter XVII, Parts 1910 and 1926, as applicable, shall be incorporated by the designer into all design and analyses. Other customer-specific health and safety regulations will be determined during the pre-design conference and incorporated in the design effort. Any problem in incorporating these standards due to conflicts with other technical criteria shall be promptly submitted to the CO for resolution.

1.3.4 Design for the Physically Handicapped

Unless specifically stated otherwise in the SOW, all facilities shall be designed to be accessible to and usable by handicapped persons in accordance with the Consolidated American Disabilities Act - Architectural Barriers Act (ADA-ABA).

1.3.5 Topographic Surveys, Easements, and Utilities

Unless otherwise specified during the pre-design conference, topographic, hydrographic, and utility surveying and mapping data will be funded and obtained. Chapter 4 SURVEY AND MAPPING provides specific instructions. Specific requirements for A-E designs will be included in the SOW. Subsurface utility investigation using Ground Penetrating Radar (GPR) or other means of determining the three-dimensional location of underground utility lines will be specifically addressed in the SOW.

1.3.6 Foundation Investigation

Unless otherwise determined during the pre-design conference, foundation investigations shall be completed and funded (including soil and rock borings, sampling, laboratory testing, and pile load tests, where applicable), as well as test such as percolation tests for septic tanks, soil resistivity tests for grounding and cathodic protection systems and infiltrometer test for storm water detention ponds. Chapter 5 GEOTECHNICAL provides specific instructions. Specific requirements for A-E designs will be included in the SOW.

1.3.7 Environmental Regulatory Permits

Responsibilities for environmental permits include:

- (a) The designer shall contact the appropriate Federal, State, local, and interstate pollution and environmental control agencies to determine the permits required and procedures and documentation necessary to obtain them. A written record of each such contact shall be prepared and furnished within five working days to the CO with copies to all parties involved.
- (b) Where formal documents are required to be submitted to obtain permits, the designer shall prepare all such documents and provide them in a "ready-for-signature" condition. This includes necessary copies of the plans, specifications, design analysis, and other required supporting documents. After review by Eglin Environmental and comment incorporation, the corrected documents will be signed by the appropriate official and submitted to the appropriate agency. Permit requirements shall be ascertained and documented by the designer during the Concept Design stage.
- (c) The designer shall provide the following information and data for each required

permit with the Concept Submittal:

- (1) Permitting Authority (State, local, etc.)
 - (2) Type of permit required (construction, operation, etc.)
 - (3) Procedure and time necessary to complete the permit application.
 - (4) Fees required.
 - (5) Statement that the project is covered by variances or that permits are not required. If a variance is required, the procedures for obtaining the variance shall be provided. If a permit is not required, reasons and supporting justification (i.e. cite state, local, and/or other regulations) shall be furnished.
 - (6) An evaluation of all State and/or local regulations to determine if monitoring devices are needed. Where required, monitoring devices shall be included in the project design.
- (d) The designer shall provide the completed permit applications not later than the Interim submittal or 60 days prior to the Final submittal, whichever is earliest. Permit applications shall be ready for signature by the appropriate official and submission to the approving authority.
- (e) With the Final submittal, the designer shall provide supporting documents, plans, and specifications. The designer shall also have accomplished the necessary coordination to obtain permit application approvals.

1.3.8 Sustainable Design

Sustainable Design is an integrated approach to planning, designing, building, operating, and maintaining facilities in a collaborative and holistic manner among all stakeholders. It is meant to provide resource efficient, environmentally friendly and healthy facilities with emphasis on renewable energy and recycled materials. The project specific criteria and rating level will be determined during the pre-design conference. The SOW will identify requirements for A-E projects.

1.3.9 Anti-Terrorism/Force Protection

Anti-Terrorism/Force Protection is an inherent part of all projects. See Chapter 18 ANTI-TERRORISM/FORCE PROTECTION for specific requirements.

1.4 DEFINITIONS

1.4.1 Design Analysis

- (a) The design analysis shall be provided with each submittal including Ready-To-Advertise (RTA) (unless it is determined during the pre-design conference that it is not required at a specific design submittal phase).
- (b) At RTA, the design analysis is not a contract document, but rather a final documentation of the basis of design for the AF Project Manager (PM), and digital

archival document for Eglin CE. The design analysis shall be developed from Concept Design to include a discussion of any new or unfamiliar products, critical product features, critical milestones that may require designer consultation, items of particular customer interest revealed in design meetings, shop drawings of particular interest or criticality, anticipated difficult construction features.

- (c) The design analysis is a written explanation of the project design and is expanded and revised for each sub mission. The design analysis shall contain a summary of the criteria for and the history of the project design, including criteria designated by the customer, letters, codes, references, conference minutes, review comments and resolution, and pertinent research. The justification for each major selection and design decision shall be clearly stated. Design calculations, computerized and manual, shall be included in the design analysis in digital format. Narrative descriptions of design solutions shall also be included. Diagrams and sketches to convey design concepts may be provided to illustrate all written material. Design phase review comments and the specific actions (annotations) taken in response to each comment from the preceding design phase review shall be included with each submission of the design analysis. Specific requirements for the design analysis are provided in other chapters of this manual.

1.4.2 Drawings

1.4.2.1 Drawings are required in each design submittal. The drawings at each submittal stage shall be complete, thoroughly checked, and coordinated. Specific drawing requirements are defined below and in other chapters of this manual.

1.4.2.2 As-Built Drawings

1.4.2.2.1 Submittal Requirements

- (a) The Contractor shall coordinate with the Eglin AFB 96 CEG drafting section, through the COR, for the version of AutoCAD to provide.
- b) The contractor shall provide 2 CD ROMs with AutoCAD and individual PDFs for each drawing. Individual PDF file name shall be the project number and index sheet number. Example “24CB48_A101”. Submittals are to be to the COR not later than ten (10) calendar days after project completion date.
- c) The drawing title blocks shall be in a uniform format to match the requirements as presented in the solicitation drawings. Scaled drawings shall provide a bar scale and shall be in feet not meters.
- d) All final As-builts shall include the assigned building number in the title block and Air Force FTFA project number. Each sheet shall be annotated in bold letters near the title block with the date the as-builts were accepted (i.e. AS-BUILT DRAWING 12 APR 2012).
- e) The As-built DWG files shall have no x-ref reference files attached as all shall be bound into the file to make one AutoCAD DWG file, which also shall be purged and created with standard AutoCAD pen table. Provide all image files that may be used on any of the sheets.

- f) The As-built DWG files shall have the Design model physical features such as floor plans and civil site plans in Model Space. Sheet features such as title blocks, notes, north arrows, and scale bar shall be in the Layout View (Paper Space).
- g) Drawings submitted for approval as As-builts shall have all changes incorporated into the final drawings. Drawings shall be free of revision clouds, hand-written notes, scanned in change orders, etc.
- h) Revision symbols shall be accompanied with an entry in the sheet's revision block. Revision block entries shall consist of a brief description of the change along with the change order number.

1.4.2.2.2 AutoCAD drawings shall have correct geometry:

- a) Civil discipline and all other site plan AutoCAD drawings shall have corrected spatial projection to one of the following:
 1. North American Datum 1983 Florida State Plane North FIPS 0903 Feet (AutoCAD Code FL83-NF)
 2. Universal Transverse Mercator 1984, Zone 16 North (AutoCAD Code UTM84-16N)
- b) Segmented lines and arcs are to be made continuous and free of self-overlapping sections, thus decreasing files size, and increasing efficiency within the AutoCAD platform. Area features such as building footprints, parking lots, roadways, and airfield pavements shall be true polyline polygons. Adjacent polygons shall not have gaps or overlaps.

1.4.2.2.3 Building Information Models (BIM)

- a) Any Building Information Models (BIM) developed for a project shall be supplied in accordance with section I.5&6 of the U.S. Air Force Building Information Modeling Minimum Requirements (current version): <http://wbdg.org> in a Model Archive as part of the final as-built submittal consisting of two sets of files:
 1. The first set shall be a collection of individual Models as received from the Model Element Author(s).
 2. The second set of files shall consist of the aggregate of those individual Models in a format suitable for archiving and viewing. The aggregate model shall also be submitted in a DWG file format.

1.4.3 Specifications

The Uniform Facilities Guide Specifications (UFGS) 48 Division format is mandatory. The specifications shall be developed in accordance with guidance provided below and in other chapters in this manual.

1.4.4 Design Build (DB)

The purpose of the design-build process is to reduce risks to the owner by assigning all responsibilities to one

single entity. It also provides shorter deadlines because you can overlap the design and construction process.

1.4.5 Design Bid Build (DBB)

There are three major parts of the DBB process.

Design: The design process involves working with an architect or engineer to design a feasible plan that can be taken to contractors during the bidding process.

Bid: The process of bidding out projects involves either “open” or “select” bidding. Open bidding is open to all contractors, while select bidding is only open to certain pre-selected contractors. Bids are analyzed by the Government for acceptability and award.

Build: The construction process is when the actual project is underway, and all the appropriate subcontractors are working on their particular tasks. The general contractor works as a go-between for subcontractors and owners, ensuring projects are on track and in budget every step of the way. They oversee resolving any issues that arise and keeping the project owner up to date with progress.

Note: In DBB projects entities are separate, this means that the designer and the construction contractor will not be working together. Therefore, it is critical that the final design is 100% in accordance with all applicable specifications.

1.5 SUBMITTAL REQUIREMENTS

1.5.1 General

Requirements for each submittal are generally described below. Additional requirements are contained in other chapters of this manual. Specific instruction for A-E design projects for number of copies, addressing, and other instructions are provided in the SOW. Covers for all submittals shall be white with black letterings. Submittals shall not include the solicitation number on the drawings, specs or covers. Submittal milestones may be altered as seen fit by the Eglin CE Project Manager and Contracting Officer.

1.5.2 Project Definition (10-15%)

This submittal represents approximately 10 to 15% of the design effort and shall be used to document and validate project requirements and the construction costs. The submittal shall include preliminary schematic plans, a narrative describing each aspect of the project including a parametric cost estimate. This level of design effort equates to the final report prepared to document charrette completion.

1.5.3 Concept Design (30-35%)

This submittal represents approximately 30-35% of the design effort and shall be of sufficient detail to show how the user’s functional and technical requirements will be met, indicate the designers’ approach to the solution of the technical problems, show compliance with design criteria or provide justification of non-compliance, and provide a valid ROM estimate of cost. The Concept Design consists of:

- (a) Design Analysis:
 - (1) Design narrative, notes, and design calculations for all disciplines.
 - (2) Intended (outline) specification list.

- (3) Environmental permitting memorandums.
- (b) Concept drawings.
- (c) Bidding schedule with Bid Options identified when applicable.
- (d) Concept ROM cost estimate.
- (e) Required information and data for each required permit.
- (f) Annotated project definition review comments.

1.5.4 Interim Design (50-60%)

This submittal, if required, is intended to ensure that funding limitations are not being exceeded and that the drawings, design analysis, specifications, and cost estimate are proceeding in a timely manner and that the design criteria and previous review comments are being correctly interpreted. Redlined, marked-up specifications shall be submitted at this design phase. The Interim Design shall consist of:

- (a) Design Analysis developed to approximately 60% completion including Bid Options where applicable.
- (b) Approximately 60% complete drawings including those addressing construction phasing.
- (c) Detailed cost estimate developed to approximately 60% completion including Bid Options where applicable.
- (d) Redlined, marked-up specifications.
- (e) Annotated Concept review comments.
- (f) Completed permit applications (if an Interim submittal was not required, the completed permit applications are required 60 days prior to the Final submittal).

1.5.5 Final Design (Unreviewed 100%)

This submittal represents a 100% complete design except for the incorporation of any review comments resulting from the review of the submittal. The Final design shall consist of:

- (a) Design Analysis with all items 100% complete. It shall include all back-up material previously submitted and revised as necessary, all design calculations, all explanatory material giving the design rationale for any design decisions which would not be obvious to an engineer reviewing the Final drawings and specifications.
- (b) 100% complete drawings including those addressing project construction phasing.
- (c) Specifications. Redlined, marked-up specifications if an Interim submittal was not made. Final edited specifications if an Interim submittal was made.
- (d) Bid Schedule and Explanation of Bid Items. Identify Bid Options where applicable.

- (e) Detailed 100% complete cost estimate.
- (f) Annotated Interim review comments.
- (g) All supporting documentation required for permit application approvals.

1.5.6 Ready-To-Advertise (RTA) (Reviewed 100%)

This submittal represents a complete design (design analysis, specifications, and drawings) including annotated design submittal review comments that answer and/or incorporate review comments resulting from the review of the Final design submittal.

Chapter 2 - Specifications

2.1 GENERAL

2.1.1 Purpose

This chapter provides guidance for the preparation of contract specifications. Architect-Engineer (A-E) designers shall use the Unified Facilities Guide Specifications (UFGS) on all projects unless specifically directed otherwise.

2.1.2 Automated Specifications

- (a) The Unified Facilities Guide Specifications (UFGS) in the Construction Specification Institute (CSI), Masterformat 2004 numbering system shall be used. These specifications consist of a total of 48 divisions versus the old numbering system of 16 divisions.
- (b) The designer shall not mismatch or combine the old 16 division specifications with the new 48 division system. Any such combining of the two systems will not be accepted and will be returned to the designer for a complete resubmittal of the project specifications.
- (c) It is highly recommended designers use SpecsIntact software as its automated specification system. This software is available for free on several sites on the internet. The following internet addresses contain necessary software, help manuals, and Unified Facilities Guide Specifications (UFGS):

SpecsIntact Software Support Unit Home Page

<http://specsintact.ksc.nasa.gov/>

Whole Building Design Guide Home Page

<http://www.wbdg.org>

- (d) Upon accessing the Whole Building Design Guide (WBDG) website, a list containing UFGS guide specification will be shown. These lists provide a divisional breakdown for the guide specifications. To retrieve the required guide specification, click on the Division in which the specification is located (i.e., Division 2; Section 02 41 00 – Demolition). Specifications downloaded from the WBDG site page are in a compressed (zipped) format as well as Adobe .pdf format. To manipulate and use these files, you must “unzip” them prior to opening the file for use.

2.1.3 Scope

The designer is responsible for the accurate preparation and coordination of the technical specifications.

2.1.4 Quality of Work

Specifications prepared by the designer shall be accurate, clear, and precise and should not be subject to interpretation. The specifications shall be specific, free of ambiguities, and well-coordinated with the drawings. The designer shall be solely responsible for insuring the relevancy and accuracy of cross-references between technical sections of the specifications.

2.2 OUTLINE SPECIFICATIONS

The designer shall submit a list of specifications with the Concept design analysis submittal. The list of specifications will support the various types of construction intended and described in the design analysis and provide a description of any specifications which must be developed for the project.

2.3 TECHNICAL SPECIFICATIONS

2.3.1 Generating Original Specifications

- (a) Designer developed specifications may only be used when UFGS specifications are not available. The original specifications must match the UFGS specifications in format and document arrangement. Designer developed specifications shall be prepared in accordance with UFC 1-300-02, Unified Facilities Guide Specifications (UFGS) Format Standard using SPECSINTACT (SI), the automated system for preparing standardized facility construction specifications. UFC 1-300-02 requires that each UFGS carry an identifying document section number in accordance with the Construction Specifications Institute (CSI) MasterFormat (MF). The UFGS specification utilize a 14 character designation of MF 2004 section numbers in the format: “NN NN NN.NN NN”, where Ns are numbers. CSI has named, numbered or otherwise reserved to the 4th level. The SI steering committee has agreed that the 5th level double digit designator would replace the former suffixes used to denote sections that are not currently unified: “A” or “10” for Army, “N” or “20” for Navy, “F” or “30” for Air Force. An example of the five-level numbering system agreed for the UFGS is as follows:

- Level 1 – **31 00 00** Earthwork
- Level 2 – **31 41 00** Shoring
- Level 3 – **31 41 16** Sheet Piling
- Level 4 – **31 41 16.11**
 - For activity or project specific use
 - For multiple contracts or alternate systems
 - For very unique narrow scope UFGS (minimal)
 - Level 5 – **31 41 16.11 10** Designation for non-unified sections
 - 10 Army
 - 20 Navy
 - 30 Air Force
 - 40 NASA
 - 50 – 90 other Future participating agencies

- (b) “Functional or descriptive specifications” are normally prepared using industry standards, manufacturer’s data, and other available information. These specifications shall be developed by listing parameters, methods, techniques, salient features, and other requirements that several manufacturers can satisfy. These specifications shall list the essential features, requirements, minimum functions, and other factors to clearly indicate the type and quality of item(s) required. Specifications shall not be developed around a single manufacturer.

- (c) Sole Source Specifications:

Sole source specifications are to be avoided. The use of trade names and proprietary

items and the drafting of a specification by adopting a manufacturer's description of a particular article or procedure shall be avoided. There may be instances, however, when only one manufacturer will satisfy the job conditions. For example, in rehabilitation work, updating a particular piece of mechanical equipment may require new parts from the manufacturer of that particular piece of equipment. In this case, specifying the "Brand" or "manufacturer's" name would be acceptable provided that "Sole Source Approval" is received from higher authority.

(d) "Or Approved Equal" Specifications:

Experience indicates that a "trade name or approved equal" description is appropriate only as a last resort and should be used with great care and discretion. When this approach is used, the contract provisions will include those salient features of the item specified upon which equality will be determined.

2.3.2 Tailoring and Coordinating of Specifications

- (a) Each specification used in the preparation of project specifications shall be tailored to fit the requirements of the project. Where entire paragraphs are not applicable, they must be deleted. Paragraphs describing systems or materials not used in the construction of the project shall be deleted. When necessary to add requirements, they must be consistent with the other requirements of the specification and must not unnecessarily restrict products that can be furnished. Prior to marking up each specification for the Interim (if this submittal is required) and Final design submittal, the designer shall review all notes attached at the beginning of the specifications. Prior to submitting the Ready To Advertise (RTA) specifications, the designer must execute the bracket verification tool if using SpecsIntact software. A complete error free report will be required before submission of the RTA specifications.
- (b) Each specification used in the preparation of project specifications shall be coordinated with other specification sections included in the project and with the project drawings. Duplication of requirements in other sections or on the drawings should be avoided. Cross-referencing of requirements will be done only when necessary to avoid misunderstanding. If the specification states "as shown" or similar wording, the requirement must be shown on the drawings. If the drawings reference the specifications, the specifications must cover the reference. If a specification references another specification, the referenced specification must be included in the project. Prior to submitting the Ready To Advertise (RTA) specifications, the designer must execute the section verification tool within the SpecsIntact software. A complete error free report will be required before submission of the RTA specifications. The designer shall insure that specifications and drawings are properly used; specifications to establish requirements such as quality and workmanship, and drawings to establish requirements such as layouts and dimensions.

2.3.3 Tailoring Specification Shop Drawing Submittals

- (a) The shop drawings typically listed in each UFGS specification are intended to cover most circumstances for a variety of projects. Not all shop drawings listed in the specification need to be included in every project. During the editing of the Shop Drawing Submittal portion of each specification, the designer should carefully consider which Shop Drawing Submittals are required from an Engineering Verification and Quality Control perspective. All submittals that are not necessary

should be deleted whether listed for “Government Approval” or “For Information Only”.

- (b) Submittals Requiring Government Approval. Shop drawings and product data submittals requiring government approval, should be limited to major pieces of equipment or systems requiring review by the designer, color selection, testing reports, etc. For each submittal that requires Government Approval, provide the desired reviewer designation “CD” for “Construction Division”, “ED” for “Engineering Division”. “ED” should be used for all submittals that are an extension of the design.

2.4 SPECIFICATION SUBMITTALS

2.4.1 Interim Submittal Specifications

If this submittal is prepared, redlined, marked-up specifications will be provided to allow reviewers to evaluate choices made by the designers. The Statement of Work (SOW) shall identify the recipients of the hardcopies.

2.4.2 100% Unreviewed Submittal Specifications

- (a) If an interim submittal is not made, 100% Unreviewed Final Submittal specifications will be provided in redlined, marked-up format in hardcopy. If an Interim submittal is made, the designer shall submit full edited specifications at the 100% Unreviewed Final Submittal Design review stage in hardcopy.
- (b) Boiler Plate (Front-end contract clauses) will be furnished by the government to the A-E for inclusion in the 100% Unreviewed Final Submittal.

2.4.3 Ready-To-Advertise (RTA) Submittal Specification

Following the 100% Unreviewed Final Submittal review, review comments will be provided to the designer. The designer shall incorporate the comments into the specifications and prepare the final specification.

Chapter 3 - Site Development

3.1 GENERAL

3.1.1 SCOPE

This chapter states the criteria, requirements, and guidance for civil engineering design. The design shall be accomplished in accordance with appropriate technical publication documents and the basic requirements furnished in the project Statement of Work (SOW).

3.1.2 QUALITY OF DESIGN

It is the purpose of Eglin Air Force Base to obtain excellent siting and civil design resulting in efficient, economical, and effective long-term paving, grading and drainage conditions.

3.2 APPLICABLE PUBLICATIONS

UFC	Unified Facilities Criteria (UFC) including UFC Series 3-200: Civil/Geotechnical/Landscape Architecture shall be utilized to provide planning, design, construction, sustainment, restoration, and modernization for Department of Defense (DoD) Projects.
AASHTO	A Policy on Geometric Design of Highways and Streets, American Association of Highway Transportation Officials
ASHRAE	American Society of Heating, Refrigerating and Air-Conditioning Engineers
IES	Illumination Engineering Society
USDOT	Manual of Uniform Traffic Control Devices (MUTCD) for Streets and Highways, United States Department of Transportation.
NPDES	State specific requirements documents and publications for National Pollutant Discharge Elimination System (NPDES) construction permits and best management plans.

3.3 PROJECT DEFINITION (10-15% Design)

The designer shall develop a narrative and conceptual site plan which describe and present the conceptual site features based on the project requirements. The narrative shall discuss siting requirements and site concerns including wetlands, Installation Restoration Program (IRP) sites, and soil and groundwater contamination. The conceptual site plan should be an efficient layout with emphasis given to user requirements. The conceptual site plan shall show building locations, parking areas, roads, limits of paving and hardstands, conceptual storm water management device locations, and pedestrian access points. The plan shall be developed to a point such that a preliminary cost estimate may be prepared.

3.4 CONCEPT DESIGN REQUIREMENTS (30-35% Design)

3.4.1 Concept Design Analysis

Provide information regarding the following as applicable:

3.4.1.1 General

- (a) General overview of major site features planned, such as building orientation, drainage patterns, parking provisions, traffic circulation, provisions for the handicapped, security requirements, airfield pavements work, etc.
- (b) Provide a description of the location of any wetlands, as defined by Federal and/or State criteria, historically significant areas, and areas with potential endangered species of wildlife within the project area. Describe and define IRP sites. All areas shall be defined by qualified professionals and flagged in the field. The project topographic survey shall label and present the defined areas. Geometric coordinates shall be clearly shown on the design drawings for all environmental areas such as an IRP site or wetland boundaries.
- (c) Provide applicable State/Local flood requirements.
- (d) Discuss existing site features including general topography, acreage, boundaries, adjacent site usage, etc.
- (e) Impacts of new construction on existing facilities. For projects with critical phasing requirements, such as airfields or projects with major impacts to existing facilities, present a preliminary phasing discussion. This preliminary phasing plan shall also be presented in plan form and shall fully discuss anticipated lengths of construction, alternate phasing schemes, and project cost impacts.

3.4.1.2 Removals

- (a) Provide preliminary discussion of any items requiring removal or relocation.
- (b) Discuss the methods and location of the disposition of waste or salvage materials.

3.4.1.3 Geometry

- (a) Provide rationale for siting of major site elements.
- (b) Airfields: Provide list of specific clearances based on airfield criteria and list manual(s) for all portions of the new work.
- (c) Work other than Airfields: Provide setback requirements or specific clearance requirements for major features of work such as buildings, parking areas from streets, hardstands, etc.

3.4.1.4 Storm Drainage

- (a) Provide a summary of specific Federal, State, and/or Local storm water permit requirements for water quality/quantity for the project including fees for permit applications and the name of the agency to which the permit application check will be written. Discuss the impacts on the site design. If no storm water permits or requirements are required, provide a statement to that effect. Provide documentation from the appropriate regulatory agency and regulators name if applicable.

- (b) Discuss the preliminary storm water design scheme and discuss impacts on the existing storm drainage system.
- (c) Provide preliminary sizes and location of storm drainpipes and collection/discharge devices.
- (d) Provide preliminary size and preliminary calculations for the required storm water treatment/storage ponds. Discuss impacts on the project site.
- (e) Provide preliminary Pre and Post construction discharge values for the applicable storm event.
- (f) Discuss the proposed storm drainpipe materials.

3.4.1.5 Grading

- (a) Discuss existing site features affecting grading such as buildings, streets, curbs, walks, fences, water courses, ponds, elevation of high ground water, rock outcrops, etc.
- (b) Provide minimum elevation to provide flood protection (if applicable)
- (c) Planned finished floor elevation (F.F.E.). Planned building shall not be inundated by flood waters created during the 100-year frequency storm event.
- (d) Cut and Fill requirements and rough estimate quantities.
- (e) Discuss minimum and maximum slopes to be used in the design for embankments, ditches, pipes, etc. Unless structural stabilization is provided, maximum slopes for pervious surfaces is 3 horizontal:1 vertical.

3.4.1.6 Pavement Structure Design

- (a) Vehicular Pavements Thickness Design.
 - i. Provide specific design values for which pavement thickness is based including number, type, and maximum weights of vehicles, category of traffic, class road or street, and resulting design index.
 - ii. Flexible Pavements – Flexible pavements shall be designed in accordance with the current version of the Florida Department of Transportation (FDOT) Flexible Pavement Design Manual.
 - iii. Rigid Pavement – Rigid Pavements shall be designed in accordance with the current version of the FDOT Rigid Pavement Design Manual.
- (b) Discuss the proposed base course type and select sub grades. Provide intended compaction requirements. All non-airfield pavements shall be designed in accordance with Florida Department of Transportation Design requirements.

3.4.1.7 Roads and Streets, and Parking Areas

- (a) Provide AASHTO design vehicle for which turning movements are to be provided for and corresponding minimum turning radius.
- (b) Provide project design speed.
- (c) Provide minimum degree of curvature and control grades per FDOT standards.
- (d) Provide applicable site and stopping distance requirements per FDOT standards.
- (e) Provide lane and shoulder widths per FDOT standards.
- (f) Provide cross-slopes for lanes and shoulders per FDOT standards.
- (g) Provide embankment slopes.
- (h) Provide requirements for sidewalks, guardrails, traffic signs and markings, fencing, etc.
- (i) Provide traffic control devices in accordance with the latest issue of the Manual on Uniform Traffic Control Devices (MUTCD)

3.4.1.8 Parking and Open Storage Areas

- (a) Discuss the types of vehicles to be accommodated.
- (b) Discuss means of determining the required number of parking spaces.
- (c) Parking stalls shall be 9' wide x 20' long.
- (d) Discuss the number, size and location of required handicapped parking stalls and associated accessible routes to buildings being served. Parking spaces shall be designed in accordance with the current ABA Standards for Accessible Design.
- (e) Provide general location of storage areas.
- (f) Provide location(s) of ingress/egress.
- (g) Provide pedestrian access to facility being served and within the parking area.
- (h) Use of 90°, 60°, or 45° parking is permitted.

3.4.1.9 Miscellaneous Site Features

- (a) Sidewalks – width and location. Sidewalk width shall take into consideration, overhang from adjacent vehicles.
- (b) Fencing – justification, type, size and location of vehicular and pedestrian gates.
- (c) Dumpster Locations – quantity of dumpsters, location, screening.

3.4.1.10 National Pollutant Discharge Elimination System (NPDES) Construction Permit.

Provide specific requirements for State and/or Federal NPDES construction permit for the project. If the project is exempt, state so.

3.4.1.11 Erosion and Sediment Control Plan

Describe the intended plan for the design of sediment and erosion control for the project. The project design engineer's responsibility for the development of the Erosion and Sediment Control plan is to provide general guidelines only and to serve as a basis in obtaining an NPDES permit. The ultimate responsibility for developing and implementing the Erosion and Sediment Control plan is the construction General Contractor's (GC). The GC shall modify and update his plan to coincide with construction schedule and activities.

3.4.1.12 Outline Specifications

Provide a list of all Unified Facilities Guide Specifications that the designer intends to prepare to use for the project.

3.4.2 Concept Drawings

The following are typical construction drawing sheets. This is a guide only. These sheets may not all be applicable to the project and may be omitted. Additional sheets may also be added if appropriate.

Title Sheet and Index
Project Location and Vicinity Maps
Project Symbols, Legends and Abbreviations Sheet
General Site Overview Plan
Geometric Layout Plan
Grading and Storm Drain Plan
Demolition and Removal Plan
Centerline Profile Sheets
Typical Sections Sheet
Composite Utility Plan
Existing Site Topography Survey and Utilities Plan
Special Project Phasing Requirements

3.4.2.1 Title Sheet and Index

- (a) Provide Project Title
- (b) Plan Sheet Index

3.4.2.2 Location and Vicinity Map

- (a) Indicate project site. Provide preliminary borrow and spoil areas, haul routes, and contractor's access to the site.
- (b) Provide State Vicinity Map
- (c) Provide Location Map for local access to the site.

- 3.4.2.3 Project Symbols, Legends, and Abbreviations Sheet
- (a) Provide graphic symbols legends (see Tri-Service Standards)
 - (b) Provide preliminary list of abbreviations used in plan assembly.
- 3.4.2.4 Provide General Site Overview Plan
- (a) Show the overall site plan of planned work (scale may be determined by the designer to best fit project requirements).
 - (b) Annotate major items of work, significant removals, and/or phasing.
 - (c) Site topography with major existing features, buildings, and/or roads shall be presented with the new work.
- 3.4.2.5 Geometric Layout Plan
- (a) Provide an overall site plan showing total development.
 - (b) Show the proposed geometry of the site plan using a minimum scale of 1" = 30' unless otherwise approved by the Contracting Officer.
 - (c) Use graphic symbols and/or line work to distinguish between new and existing site work.
 - (d) Provide sufficient geometric information to adequately locate all new major site elements.
 - (e) Identify the coordinate system used. Include a North arrow.
 - (f) Provide centerline stationing for all roads, streets, parking areas, runways, taxiways, etc.
- 3.4.2.6 Grading and Storm Drainage Plan
- (a) Show the complete drainage concept using finished contours and slope arrows where applicable.
 - (b) Use a minimum scale of 1" = 30' unless otherwise approved.
 - (c) Show and identify all existing buildings and facilities on plan.
 - (d) Show the proposed finished floor elevation and critical spot elevations.
 - (e) Provide control monument data, and list vertical and horizontal data for each.
 - (f) Reflect existing utilities with the topography. If necessary for clarity, show removals, relocations, and new work for utilities on separate plans.

- (g) All contour intervals shall be 1-foot.

3.4.2.7 Demolition and Removal Plan

- (a) Indicate items to be demolished and/or removed.
- (b) Pavement structures: Indicate pavement layer thickness for removal depths if information is available.
- (c) Drawing scale shall match the geometric layout and grading plans scales.

3.4.2.8 Centerline Profile

- (a) Roads and Streets: Provide preliminary centerline profile. Show existing ground line and preliminary new finish grade with percent new grades and vertical curve data indicated.

3.4.2.9 Typical Sections (New Work) for Roadways and Parking areas

- (a) Roadways: Provide preliminary typical sections presenting each different roadway type or width. Indicate lane widths, shoulder widths, curb and gutter, and cross-slope.
- (b) Parking Areas: Provide preliminary typical pavement sections for various parking areas.

3.4.2.10 Composite Utility Plan

Present the new and existing site features with all utilities underground and overhead shown.

3.4.2.11 Existing Site Topographical Survey and Utilities Plan

Present the site topographical survey.

3.4.2.12 Project Construction Phasing Plan

Present the preliminary project phasing requirements. Show impacts to existing facilities and the preliminary plan of each construction phase.

3.5 INTERIM DESIGN REQUIREMENTS (50-65%)

Advance from concept into design. Comply with comments from the concept review.

3.5.1 Design Analysis

Update and expand the Concept Design Analysis to support the submittal and include the following as applicable:

3.5.1.1 Storm Drainage Design

- (a) Complete storm drainage design-calculations consistent with the requirements of the applicable UFC(s), state requirements, federal requirements, and based on the design values established in the Concept Design Analysis.
- (b) Provide a map outlining drainage areas affecting new construction.
- (c) Use the General Instructions Relative for the Water Storage, Distribution, and Transmission, with Change 2 found in UFC 3-230-01.
- (d) Provide complete calculations for sizing retention and/or detention ponds. Provide calculations verifying compliance with all State regulations. Coordinate calculations with applicable State Regulatory Agencies. Provide documentation of coordination meetings.
- (e) Provide watertight joints for drainage pipe under all pavements when the pipe is placed in a non-cohesive soil. Provide soil-tight joints at all other locations.

3.5.1.2 Pavement Design

- (a) Complete flexible and/or rigid pavement design calculations consistent with the requirements of the applicable UFC's, FDOT Design Manuals, and the U.S. Army Pavement-Transportation Computer Assisted Structural Engineering (PCASE) pavement design software program.
- (b) Present complete calculations for pavement options to be allowed.
- (c) Provide materials to be used in pavement structure and their thickness.
- (d) Provide the minimum compaction requirements.

3.5.2 Interim Drawings

Although it is intended that major items of work be shown separately, different items may be shown on the same sheet provided that the presentation is sufficiently clear to permit legible reproduction at half-scale.

3.5.2.1 Location and Vicinity Maps

Update from 35% as required.

3.5.2.2 Project Symbols, Legends and Abbreviations Sheet

- (a) Update from 35% as necessary, provide graphic symbols for all items used in plan assembly.
- (b) Provide a list of all abbreviations used in plan assembly.

3.5.2.3 Demolition and Removal and/or Relocation Plan

- (a) Indicate all items of site work which shall require removal or relocation.
- (b) Provide dimensioning for removal items such as pavements, curbs, sidewalks, etc.

3.5.2.4 General Site Overview Plan

This sheet may be omitted for small projects where the complete site can be presented on one geometric layout sheet(s). For larger projects, update this sheet from the 35% to present the 65% design.

3.5.2.5 Geometric Layout Plan

- (a) Complete the geometric layout of all items of new work using offset dimensions from existing structures or use coordinates for locating new work. Coordinates shall be to the one-hundredth (0.01) of a foot.
- (b) Include on the plan sheet information on specific items of work.
- (c) Provide locations of soil boring locations and designation.
- (d) Complete the legend to include all items and symbols shown on the plans. Symbols should be consistent between successive drawings.
- (e) Show on the plan the construction centerline, right-of-way limits, and all critical topographical features such as fences, buildings, streams, railroads, etc.
- (f) Locate or make reference to monuments and benchmarks for horizontal and vertical control.
- (g) Provide layout survey information necessary for establishment of the survey centerline, new structures, building column lines, runway centerlines, etc., including coordinates or computed bearings, radii, curve data, super-elevation requirements, pavement widening requirements, points of intersection of centerlines, etc.
- (h) When super-elevation is required, include in the plan a diagrammatic profile of how the super-elevation is obtained and tables of shoulder slopes versus cross slopes for the super-elevated section.
- (i) Unless otherwise shown on the demolition and removal plan, note on the plan the size and type of all existing structures and the manner in which they are to be utilized, removed, or otherwise affected by new work.
- (j) If widening of the pavement is required in curves, provide sufficient data to facilitate the construction.

3.5.2.6 Grading and Storm Drainage Plan

- (a) Indicate all items of work superimposed on the existing topography.
- (b) Indicate the proposed contours for new grading and provide spot elevations as required to facilitate field layout. All contours shall be 1-foot intervals.
- (c) Layout the new storm drainage system using the symbols presented in the legend.
- (d) Identify drainage structures with number designations corresponding to those used in the storm drainage schedule to be included in the drawings.

- (e) Indicate the finished floor elevations of new buildings.
- (f) Locate or refer to monuments and benchmarks for horizontal and vertical control.
- (g) Present clearing and grubbing limits.

3.5.2.7 Centerline Profile Sheets

- (a) Roads, Streets, & parking Areas: Update from the 35%: present the interim design profile for centerlines. Show existing ground line and interim new finish grade with percent new grades and vertical curve data indicated.
- (b) Unless otherwise approved, use a 10:1 vertical to horizontal exaggeration or as appropriate to terrain as approved. Indicate and label beginning and ending points.
- (c) Provide elevations at points where changes of grade occur.
- (d) Indicate the percentage of slope for all grade lines. Provide special information pertaining to the profile and affecting the design such as curb grades, gutter grade, drainage structure inverts and top elevations, etc.
- (e) Provide centerline grade elevations at each 50-foot station.
- (f) Show new and existing drainage and sanitary structures on the profile.

3.5.2.8 Storm Drain Profiles

Provide interim design profiles for all storm drains and roadway culverts. Show existing ground line and interim new finish grade. Indicate invert elevations of all drainage structures, storm drainpipes with size(s) and invert elevations, and new or existing structures or utilities crossing above or below the new storm drain.

3.5.2.9 Typical Sections (New Work) for Roadways & Parking Areas

- (a) Roadways: Update preliminary typical sections present each different roadway type or width. Indicate lane widths, shoulder widths, curb and gutter, and cross- slope.
- (b) Parking Areas: Update preliminary typical sections for various parking areas.
- (c) Present typical pavement structure diagrams or show layers on typical section.
- (d) Define on typical section, the various layers of new work: stripping, unclassified excavation, compacted fill, shoulder build-up, pavement section, pavement widths, shoulder widths, ditch widths, earthwork slopes, seeding, sodding, and all special requirements as necessary for the specific project.

3.5.2.10 Concrete Joint Plans

- (a) Concrete Joint Layout plans: Provide a joint layout plan for each concrete apron, hardstand, road, pavement, etc. Joint plan shall clearly indicate the required joint type for all joints as well as specific slabs which require reinforcement. The scale of

layout plans shall be enlarged to clearly show all details for layout and grading. Typical scale shall be 1" = 10' or 1" = 20' or unless otherwise approved.

- (b) Concrete Joint Grading Plans: Provide a joint grading plan for all concrete pavements, hardstand, road, pavement, etc. Grade for each joint intersection shall be provided on the plan at the specific joint. Only joints with grades which can be linearly interpolated, may be omitted. Sufficient grades must be provided to facilitate calculation of all joints on the plan. Scale of the grading plan shall be as described in 4.5.2.10(a) above.
- (c) Concrete Joint Details: Provide details of all joint types as applicable to the project. Provide detail of joint sealant.
- (d) Sidewalk Joint Layout: Provide details of sidewalk joints for entrances at buildings, handicapped ramps, and circular drives, etc. as applicable.

3.5.2.11 Construction Details and Special Plans

Plans shall include the following:

- (a) Minimum paving and compaction requirements not otherwise presented by the typical sections.
- (b) Typical sections through the building site as required for clarity.
- (c) Storm Drainage Details: inlets, manholes, pipe bedding, headwalls, special structures, and pipe drainage structure schedule(s) as required.
- (d) Parking Layout(s)
- (e) Super-elevation and widening details.
- (f) Pavement Marking and Signage:
 - i. Marking and signage plans for vehicle traffic shall be based on the criteria presented in the current issue of the MUTCD and FDOT Standard Drawings and Specifications.
- (g) Sidewalk, curb, curb and gutter, ditch(s), pedestrian ramps, miscellaneous ramps, drives, hardstands, brick paving, etc.
- (h) Enlargement sheets; to present all construction details clearly, provide enlargement plans or details as necessary.
- (i) Traffic Control Plans. On projects which interface with existing streets or roadways which will remain open to traffic during construction activities, a Traffic Control Plan shall be developed and presented in the plan assembly. The plan shall be in accordance with the MUTCD.

3.5.2.12 Composite Utility Plan

- (a) Update the preliminary new and existing site plan with all utilities underground and overhead shown.
- (b) Coordinate and resolve utility conflicts as necessary.

3.5.2.13 Existing Site Topographical Survey and Utilities Plan

- (a) Present the site topography survey.
- (b) Present any special notes and locations of IRP sites, wetlands, or other environmentally sensitive areas. Present any archeological or culturally significant areas.

3.5.2.14 Preliminary Best management Practices Plan (Erosion and Sediment Control Plan)

- (a) For all projects with land disturbance, provide a Best Management Practices (BMP) Plan. The plan shall be prepared by a Professional Engineer registered in the State of Florida. The plan shall present the preliminary “best management practices” both temporary and permanent, anticipated to control sedimentation and erosion throughout the life of the project. The General Contractor (GC) shall be responsible for retaining a qualified professional to modify and update the BMP Plan as necessary through the phases of construction to coordinate with construction activities controlled by the GC. The GC is responsible for obtaining any required NPDES permits and for adhering to all requirements of that permit including periodical inspections, reports, and logging of all modifications.

3.6 FINAL DESIGN (UNREVIEWED 100%)

This submittal may also be referred to as the 95% Design. Advance design of all plan and details sheets to completion. Present the complete design for layout, grading, materials, marking, demolition and removal, drainage, erosion control, traffic control, and construction phasing information with complete construction details. Resolve or comply with comments from the previous reviews.

3.6.1 Final Design Analysis

3.6.1.1 Update previously prepared analysis to support final plans and specifications. Any required permit application packages shall be included as an appendix in the Final Design Analysis.

3.6.2 Final Drawings

- (a) Add general notes to drawings as required.
- (b) Insure correct cross-referencing among site drawings for appropriate details, sections, match lines, etc.
- (c) Eliminate all conflicts (horizontal and vertical) among site plans and architectural, structural, and utilities plans.

3.7 READY-TO-ADVERTISE SUBMITTAL REQUIREMENTS (100% REVIEWED)

3.7.1 RTA Design Analysis

Complete analysis supporting the requirements of the project.

3.7.2 RTA Design Drawings and Specification

Complete thoroughly checked drawings and specifications, with all comments from the final review incorporated. Any required permit application changes, permit approval letters, and/or any requirements that apply to project construction shall be included as an appendix in the specifications.

Chapter 4 - Survey and Mapping

4.1 GENERAL

This chapter presents general requirements for surveying and mapping and the processing of the data that may be required for the work necessary in the design and advance planning of assigned projects. All labor, materials, and equipment necessary to perform site surveying and mapping services are required. Adequate professional supervision and quality control to assure the accuracy, quality, and completeness of the site surveys is required.

4.2 APPLICABLE PUBLICATIONS

USACE, Mobile District, Manual of Instructions for Geodesy, Cartography, Hydrography and Photogrammetry

EM-385-1-1 Safety and Health Requirements Manual

ERDC/ITL TR-01-6 Architect/Engineer/Contractor (A/E/C) Computer Aided Design and Drafting (CADD) Standards

EM 1110-1-1000 Photogrammetric Manual

EM 1110-1-1003 NAVSTAR Global Positioning System Manual

EM 1110-1-1004 Geodetic and Control Surveying

EM 1110-1-1005 Topographic Surveying

EM 1110-2-1003 Hydrographic Surveying

The referenced publications (Engineering Manuals (EM's), Technical Manuals (TM's), and other references) may be applicable for site surveying and mapping for design of assigned projects. The EM's listed take precedence over District Manuals.

The Manual of Instructions for Geodesy, Cartography, Hydrography and Photogrammetry for the Mobile District, dated January 1988, can be acquired from:

U. S. Army Engineer District, Mobile
Attention: CESAM-EN (Survey Unit)
Post Office Box 2288
Mobile, Alabama 36628-0001

4.3 PROJECT DEFINITION

4.3.1 General Statement of Surveying and Mapping Services. The designer shall submit a general statement (scope of work) as to what type surveying and mapping services will be required for the site plan. The following information is required:

- (a) Name and location of the project.
- (b) Type of surveying and/or mapping services (geodetic, topographic, hydrographic,

route location surveys, etc.).

- (c) English or metric surveys.
- (d) Site map to scale showing area to be surveyed (acres, length of route location survey, etc.). Scale required for the new survey (1"=30", 1"=50", 1"=100", 1"=200', etc.) and contour interval (1', 2', 5', etc.).
- (e) General description of utilities (above and/or underground) that will be located (if applicable), along with other special requirements or features that need to be identified such as trees or wetland areas.

4.3.2 Existing Horizontal and Vertical Site Control

Existing horizontal and vertical control shall be obtained from the Corps of Engineers at the following address:

U. S. Army Engineer District, Mobile
Attention: CESAM-EN (Survey Unit)
Post Office Box 2288
Mobile, Alabama 36628-0001

The Government will furnish all pertinent horizontal and vertical control data on file, if available. The following information is required:

- (a) Location and name of the project.
- (b) General site map showing location and coordinate values (NAD27 or NAD83) of the project area.

4.4 CONCEPT OF SURVEYING AND MAPPING SERVICES

The following surveying and mapping services may be necessary in the design and advance planning of assigned projects.

4.4.1 Geodetic and Control Surveys

These include surveys in which the figure and size of the earth are considered and is used for precise location of basic points suitable for controlling other surveys. These include all orders of horizontal and vertical control surveys, geodetic astronomy, gravity and magnetic surveys in accordance with the Standards and Specifications for Geodetic Control Networks published by the Federal Geodetic Control Committee. Conventional, electronic instrumentation, inertial, satellite and other survey methods, as applicable, may be utilized.

4.4.2 Topographic Engineering and Construction Surveys

These include acquisition of topographic surveying and mapping data representing three dimensional spatial relationships on the earth's surface. This data may be required for planning, cost estimating, engineering, design, construction, master planning, operations, and recording as-built conditions. Conventional and electronic instrumentation, remote sensing, inertial, satellite and other survey methods, as applicable, may be used.

4.4.3 Route Location Surveys

These include roads, railroads, levees, and channels, etc.

4.4.4 Quantity Surveys

These include preconstruction and/or final cross sections and computations of quantities.

4.4.5 Layout Surveys

These include staking of buildings, structures, utilities, roads, railroads, etc.

4.4.6 Hydrographic Engineering and Construction Surveying

These include surveys of channels, lakes, rivers, bays, and open coastal waters in support of engineering design, construction, operations and maintenance include acquisition of hydrographic and surveying and mapping data representing three dimensional spatial relationships on the earth's surface. This data may be required for planning, cost estimating, engineering, dredging, design, construction, sedimentation, master planning, operations, and as-built conditions. Conventional and electronic instrumentation, and remote sensing, inertial, satellite, side scan sonar, sub-bottom profiling, marine magnetometer, and other surveying methods, as applicable, may be utilized.

4.4.7 Precise Surveys

These include third order or better horizontal and vertical surveys required to monitor movement of structures or precise location of structures.

4.4.8 Boundary and Cadastral Surveying

These include property, boundary and easement surveys, etc. Conventional, electronic instrumentation, inertial, satellite, and other survey methods, as applicable, may be utilized.

4.4.9 Photogrammetric Services

These include acquisition of surveying and mapping data from measurement of photographs representing either three dimensional or planimetric spatial relationships on the earth's surface. Stereo plotting, bridging, photographic laboratory and reproduction services, acquisition of aerial photography, drafting and scribing, photogrammetric mapping to include film negatives, film and glass positives, photo indexes, photo enlargements, computations, scribecoats, compilation histories, and mapping on stable base materials may be required.

4.4.10 Supplemental Map Control (SMC)

This includes establishment of third order horizontal and vertical control on photo identifiable points for photogrammetric mapping.

4.4.11 Cartographic Surveying

These include acquisition and assimilation of topographic and/or hydrographic surveying and mapping data for preparation of maps, charts, and similar products for planning. Conventional and electronic instrumentation, inertial, satellite and other survey methods, as applicable, may be utilized.

4.4.12 Subsurface Utility Investigations

- (a) Where there are several known utilities and communication lines crossing the proposed construction site, a Subsurface Utility Investigation is recommended. Typically, Subsurface Utility Investigations are categorized based on the quality of information obtained in an ascending level as follows:

Quality Level D - A search of all reasonably accessible utility databases from surveys, Base As-Built drawings and Base maps, and public utility company drawings.

Quality Level C - A physical site investigation of aboveground infrastructure associated with utilities such as manholes, valve boxes, utility poles, etc, to access the general accuracy of surveys, Base As-Built drawings and Base maps, and public utility company drawings.

Quality Level B - involves the use of surface geophysical techniques to determine the existence and horizontal position of underground utilities and communication lines utilizing electromagnetic, two-dimensional ground penetrating radar (GPR), Computer Assisted Radar Tomography (CART), or other means.

Quality Level A - involves the use of nondestructive digging techniques, such as vacuum extraction, at critical points to determine the precise horizontal and vertical position of underground utilities, as well as the type, size, condition, material, and other characteristics.

- (b) The minimum acceptable Subsurface Utility Investigation shall be a Quality Level B. All subsurface utilities and communications lines shall be located to an accuracy of +/- 6-inches (0.15M). All subsurface utility information obtained during the investigation shall be shown on drawings containing the topographical survey.

4.4.13 Mapping and Charting

These include the preparation (i.e., design, compilation, digitizing, scribing, drafting, and printing) of map and chart products. These depict man-made and natural features of a part to the surface of the earth in their correct positions and at an established scale relative to a coordinate reference system. These maybe associated with engineering, land/boundary, geodetic and/or cartographic surveys. Conventional, electronic, or computer assisted design & CADD systems as applicable may be utilized.

4.4.14 Digital Data

A digital CADD file with the survey data is required in AutoCAD 2020. The designer shall store and maintain a copy of all electronically created digital files (CD's, tapes and disc) through the construction phase of the project. The CD's, tapes and disc shall be made available to the government upon request and shall be maintained with no additional cost to the Government. AutoCAD drawings shall be georeferenced. All external references shall be bound to individual drawing to which they pertain.

4.4.15 AutoCAD Layering Standard

The list of standard CADD layer names shown in **Exhibit 4-1** shall be utilized for topographical surveys. Where strict adherence to this naming standard is not possible, the layer names assigned shall easily identify those elements placed on that particular layer and follow the same layer naming logic.

4.5 MINIMUM TECHNICAL STANDARDS FOR SURVEYING AND MAPPING SERVICES

4.5.1 Registered Land Surveyor

All surveying and mapping services shall be accomplished under the direction/supervision of a Registered Land Surveyor in the State in which the project is located. Site plan mapping shall be signed and sealed with the following statement: "I HEREBY STATE THAT THIS SURVEY AND DRAWING(S) MEETS OR EXCEEDS THE MINIMUM TECHNICAL STANDARDS FOR THE PRACTICE OF LAND SURVEYING IN (insert State in which survey was performed)".

4.5.2 Horizontal and Vertical Datum

Unless otherwise stated within the Scope of Work, all horizontal data shall be referenced to NAD83 with a projection in the local state plane coordinate system. Unless otherwise stated within the Scope of Work, all vertical data shall be referenced to NAVD88. The use of a geoid model to convert from ellipsoid heights to orthometric heights is permissible only with the GEOID 03 model or a later version, unless a different model is explicitly state within the scope of work. The site survey shall be accomplished with no less than third (3rd) order accuracy and procedure. Assumed coordinates and vertical positions can be used only with the Government's permission. CADD drawings shall indicate what horizontal and vertical control datum were used for the site surveys.

4.5.3 Survey Monuments

A minimum of three (3) permanent survey control points shall be established on or adjacent to the design site. Survey control points must be established in areas that will not be disturbed prior to and during the construction phase of the project. Designation and date established shall be stamped on each survey control point. No less than third (3rd) order horizontal and vertical control shall be established on each survey control point. A detailed description with horizontal and vertical datum shall be indicated on the site plan survey and design drawings. The following are requirements for a survey monument:

- (a) Be composed of a durable ferrous or magnetic material with minimal length of eighteen (18) inches and cross-section area of material of 0.3 square inches.
- (b) Be identified with durable marker or cap bearing designation, date and Registration Number of the land surveyor in responsible charge.
- (c) Be detectable with conventional instruments for finding ferrous or magnetic objects.

4.5.4 Site Plan Drawing(s)

All permanent survey control points established on site shall be shown on the final design drawings. Inserts on the drawing and/or digital files shall show a detailed sketch of the location with description of the permanent control points established on site. Course chart on the drawings shall show coordinate and vertical values of each permanent monument. The following is an example of a course chart:

NAME OF PROJECT AND LOCATION

Designation Of Point	Type mark And date	Northing SPC w/zone NAD83 (ft)	Easting SPC w/zone NAD83 (ft)	Elevation NAVD 88 (ft)
21A-3B	CONC. MON, 1994	345,123.34	1,234,456.00	234.56 FT

21A-3C	REBAR	345,140.66	1,234,400.56	246.98 FT
BB-3	REBAR	345,340.45	1,234,645.14	250.42 FT
21A-3D	CONC. MON 1994	345,450.98	1,234,823.34	254.10 FT
212-3	3/4" IRON ROD	345,003.45	1,234,700.98	224.21 FT
212-4	3" PVC PIPE (WE)	256,234.67	1,989,067.00	225.90 FT

4.5.5 Compliance with Applicable Laws

All personnel shall strictly observe the laws of the United States or other governing body affecting operations at all sites. The personnel shall comply with all applicable laws under which they are operating including those concerning the inspection and operation of equipment and the licensing of engineers, land surveyors, pilots, mechanics, and other personnel. It is further understood and agreed that the designer assumes full responsibility for the safety of his employees, plant, and materials.

4.5.6 Security Clearance

Personnel working on military projects shall be capable of obtaining a temporary security clearance. The following information could be required if the project is in a restricted area: Full Name, Position, Social Security Number, Date of Birth, Place of Birth, Security Clearance, Citizenship, Driver's License Number and State of Driver's License. Include with this list the Name and Phone Number of a Point of Contact in case of an Emergency. It is the responsibility of the Designer to assure all personnel listed can obtain the clearance.

4.6 DESIGNER'S RESPONSIBILITY FOR UNSATISFACTORY SITE SURVEYS

If the site surveying and mapping services is found to be in error prior to and through the construction phase of the project, the designer shall be responsible for all cost in connection with correcting such errors. The designer shall be and shall remain responsible to the Government in accordance with applicable law for all damages to the Government caused by negligent performance of any services.

Exhibit 4-1 Standard AutoCAD Layers for Topographical Surveys

Below are AutoCAD layers used by the Mobile District's Site Development Section to aid the site designer in the development of site model files. The layering names follow the same basic scheme as dictated in the Tri-Service CADD Standard with the addition of the suffices "DM" for Demolition (removal), "EX" for existing features, and "NW" for new or proposed features. These layers allow easier manipulation of layers by other disciplines when using the Site Model File as a reference file to their designs. The surveyor has the liberty of creating additional layers, however, the Corps recommends that the same basic logic as represented in the Tri-Service Standard be used.

The color and line type of each drawing entity shall be drawn using the BY-LAYER setting. This will allow the color and line type to be easily manipulated to suit the District's or the Base's pen table.

C-ANNO-PATT	Miscellaneous Patterns, Hatching.
C-ANNO-DIMS	Dimension Lines, Arrowheads, and Text.
C-ANNO-KEYN	Keynotes with leader lines and arrowheads.
C-ANNO-NOTE	General Notes
C-ANNO-NPLT	Construction Lines, viewport windows.
C-ANNO-SYMB	Miscellaneous Symbols.
C-A NNO-TEXT	Miscellaneous Text, leader lines, and text.

C-A PRN-OTLN-DM	Apron outline.
C-APRN-OTLN-EX	
C-A PRN-OTLN-NW	
C-A PRN-TXT-DM	
C-APRN-TXT-EX	
C-A PRN-TXT-NW	
C-B LDG-OTLN-DM	Building and primary structure outlines
C-BLDG-OTLN-EX	
C-B LDG-OTLN-NW	
C-B LDG-TXT-DM	Building and primary structure text
C-BLDG-TXT-EX	
C-B LDG-TXT-NW	
C-C ONTMJ-LINE-DM	Major contour lines
C-CONTMJ-LINE-EX	
C-C ONTMJ-LINE-NW	
C-C ONTMJ-TEXT-DM	Major contour line text
C-CONTMJ-TEXT-EX	
C-C ONTMJ-TEXT-NW	
C-CONTMN-LINE-DM	Minor contour lines
C-CONTMN-LINE-EX	
C-CONTMN-LINE-NW	
C-CONTMN-TEXT-DM	Minor contour line text
C-CONTMN-TEXT-EX	
C-CONTMN-TEXT-NW	
C-E LEC-LINE-DM	Electrical lines (OH and UG)
C-ELEC-LINE-EX	
C-E LEC-LINE-NW	
C-E LEC-TXT-DM	Electrical line text
C-ELEC-TXT-EX	
C-E LEC-TXT-NW	
C-F ENC-LINE-DM	Fence lines
C-FENC-LINE-EX	
C-F ENC-LINE-NW	
C-F ENC-TXT-DM	Fence line text
C-FENC-TXT-EX	
C-F ENC-TXT-NW	
C-G AS-LINE-DM	Gas lines
C-GAS-LINE-EX	
C-G AS-LINE-NW	
C-G AS-TXT-DM	Gas line text
C-GAS-TXT-EX	
C-G AS-TXT-NW	
C-PAVE-JNT-DM	Pavement Joints
C-PAVE-JNT-EX	

C-PAVE-JNT-NW C-PAVE-TXT-DM C-PAVE-TXT-EX C-PAVE-TXT-NW	Pavement Joint Text (Elevations)
C-PKNG-OTLN-DM C-PKNG-OTLN-EX C-PKNG-OTLN-NW	Parking outline
C-PKNG-PVMK-DM C-PKNG-PVMK-EX C-PKNG-PVMK-NW	Parking pavement markings
C-PKNG-TXT-DM C-PKNG-TXT-EX C-PKNG-TXT-NW	Parking text.
C-R AIL-CNTL-DM C-RAIL-CNTL-EX C-R AIL-CNTL-NW	Railroad centerlines.
C-R AIL-OTLN-DM C-RAIL-OTLN-EX C-R AIL-OTLN-NW	Railroad outlines.
C-R AIL-TXT-DM C-RAIL-TXT-EX C-R AIL-TXT-NW	Railroad text.
C-R IPR-OTLN-DM C-RIPR-OTLN-EX C-R IPR-OTLN-NW	Riprap outline
C-R OAD-CNTR-DM C-ROAD-CNTR-EX C-R OAD-CNTR-NW	Road centerline.
C-R OAD-CURB-DM C-ROAD-CURB-EX C-R OAD-CURB-NW	Road curbs
C-R OAD-GARD-DM C-ROAD-GARD-EX	Road guardrails
C-R OAD-GARD-NW C-R OAD-OTLN-DM C-ROAD-OTLN-EX C-R OAD-OTLN-NW	Road outline
C-R OAD-TXT-DM C-ROAD-TXT-EX C-R OAD-TXT-NW	Road Text.
C-R UNW-CNTL-DM C-RUNW-CNTL-EX C-R UNW-CNTL-NW	Runway centerlines.
C-R UNW-OTLN-DM C-RUNW-OTLN-EX C-R UNW-OTLN-NW	Runway outline

C-R UNW-TXT-DM C-RUNW-TXT-EX C-R UNW-TXT-NW	Runway Text
C-S IGN-OTLN-DM C-SIGN-OTLN-EX C-S IGN-OTLN-NW	Signs
C-S IGN-TXT-DM C-SIGN-TXT-EX C-S IGN-TXT-NW	Sign Text
C-S NSW-LINE-DM C-SNSW-LINE-EX C-S NSW-LINE-NW	Sanitary Sewer lines.
C-S NSW-MNHL-DM C-SNSW-MNHL-EX C-S NSW-MNHL-NW	Sanitary Sewer Manholes.
C-S NSW-TXT-DM C-SNSW-TXT-EX C-S NSW-TXT-NW	Sanitary Sewer Text.
C-S TEAM-LINE-DM C-STEAM-LINE-EX C-S TEAM-LINE-NW	Steam lines
C-S TEAM-TXT-DM C-STEAM-TXT-EX C-S TEAM-TXT-NW	Steam line text
C-S TRM-HDWL-DM C-STRM-HDWL-EX C-S TRM-HDWL-NW	Storm water headwalls
C-S TRM-LINE-DM C-STRM-LINE-EX C-S TRM-LINE-NW	Stormwater lines.
C-S TRM-MNHL-DM C-STRM-MNHL-EX C-S TRM-MNHL-NW	Stormwater manholes.
C-S TRM-TXT-DM C-STRM-TXT-EX C-S TRM-TXT-NW	Stormwater text.
C-S URV-BND-LNS C-S URV-BND-TXT C-SURV-CNTL-PTS C-S URV-CNTL-TXT	Survey boundary lines. Survey boundary line text. Survey control points. Survey control text.
C-T AXI-CNTR-DM C-TAXI-CNTR-EX C-T AXI-CNTR-NW	Taxiway centerlines.
C-T AXI-OTLN-DM C-TAXI-OTLN-EX	Taxiway outlines.

C-T AXI-OTLN-NW C-T AXI-TXT-DM C-TAXI-TXT-EX C-T AXI-TXT-NW	Taxiway text.
C-T OPO-BORE C-T OPO-COOR C-T OPO-GRID C-TOPO-SPOT-DM C-TOPO-SPOT-EX C-T OPO-SPOT-NW C-T OPO-TXT-DM C-TOPO-TXT-EX C-T OPO-TXT-NW	Topographical Soil borings. Topographical coordinates Topographical grid tick marks Topographical spot elevations Topographical text.
C-VEG-OTLN-DM C-VEG-OTLN-EX C-VEG-OTLN-NW C-VEG-TXT-DM C-VEG-TXT-EX C-VEG-TXT-NW	Vegetation outline Vegetation text.
C-WALK-OTLN-DM C-WALK-OTLN-EX C-WALK-OTLN-NW C-WALK-TXT-DM C-WALK-TXT-EX C-WALK-TXT-NW	Walkways. Walkway text.
C-WATF-OTLN-DM C-WATF-OTLN-EX C-WATF-OTLN-NW C-WATF-TXT-DM C-WATF-TXT-EX C-WATF-TXT-NW C-WATR-HYDT-DM C-WATR-HYDT-EX	Water Feature outline. Water Feature text. Water hydrants
C-WATR-HYDT-NW C-WATR-LINE-DM C-WATR-LINE-EX C-WATR-LINE-NW C-WATR-TXT-DM C-WATR-TXT-EX C-WATR-TXT-NW	Water lines. Water line text.

Chapter 5 - Geotechnical

5.1 GENERAL

This chapter outlines the content of subsurface investigations, geotechnical design reports, geotechnical design analyses, and geotechnical data for inclusion in design and contract documents. A geotechnical design report is typically identified as a “Foundation Report” for projects that include structures as primary features but may otherwise be identified as a “Subsurface Investigation Report”. The term “Geotechnical Report” is used synonymously for both types of reports hereinafter. The geotechnical report shall be provided to all designers for use in design and incorporated in the various submittal stages. The Architect-Engineer (A-E) shall plan and perform such geotechnical subsurface investigation at the project site as required and provide to the designer a comprehensive Geotechnical Report as early in the design as practicable but not later than the Interim Design (50-65%) submittal. This chapter also lists the specific requirements of the submittal stages for geotechnical design features.

5.2 APPLICABLE PUBLICATIONS

5.2.1 American Society for Testing and Materials (ASTM) Specifications

Many of the "Guide Specifications" reference ASTM specifications. Most of the ASTM specifications that are usually referenced by geotechnical specifications can be found in Volume 04.08 of ASTM. Listed below are the most frequently used ASTM specifications.

C 117-95	Test Method for Material Finer Than 75-um (No. 200) Sieve in Material Aggregates for Washing
C 136-84	Method for Sieve Analysis of Fine and Coarse Aggregates
D 420-87	Recommended Practice for Investigating and Sampling Soil and Rock for Engineering Purposes
D 421-85	Practice for Dry Preparation of Soil Samples for Particle-Size Analysis and Determination of Soil Constants
D 422-63	Method for Particle-Size Analysis of Soils
D 653-90a	Terminology relating to Soil, Rock, and Contained Fluids
D 698-91	Test Method for Laboratory Compaction Characteristics of Soil Using Standard Effort (12,400 ft-lb/ft ³) (600kN-m-m/3)
D 1140-54	Test Method for Amount of Material in Soils Finer than the No. 200 (75- um) Sieve
D 1241	Specification for Materials for Soil-Aggregate Subbase, Base, and Surface Courses
D 1452-80	Practice for Soil Investigation and Sampling by Auger Borings (1990)

- D 1556-90 Test Method for Density and Unit Weight of Soil in Place by the Sand- Cone Method
- D 1557-91 Test Method for Laboratory Compaction Characteristics of Soil Using Modified Effort
- D 1586-84 Method for Penetration Test and Split-Barrel Sampling of Soils
- D 1587-83 Method for Thin-Walled Tube Sampling of Soils D 2113-83 Method for Diamond Core Drilling for Site Investigation (1987)
- D 2167-84 Test Method for Density and Unit Weight of Soil In-Place by the Rubber Balloon Method (1990)
- D 2216-90 Test Method for Laboratory Determination of Water (Moisture) Content of Soil and Rock
- D 2487-90 Classification of Soils for Engineering Purposes
- D 2488-90 Practice for Description and Identification of Soils (Visual-Manual Procedure)
- D 2922-91 Test Methods for Density of Soil and Soil-Aggregate in Place by Nuclear Methods (Shallow Depth)
- D 2937-83 Test Method for Density of Soil in Place by the Drive-Cylinder
- D 3017-78 Test Method for Moisture Content of Soil and Soil-Aggregate in Place by Nuclear Methods (Shallow Depth)
- D 3740-88 Practice for Evaluation of Agencies Engaged in Testing and/or inspection of Soil and Rock as Used in Engineering Design
- D 4043-91 Guide for Selection of Aquifer Test Method in Determining Hydraulic Properties by Well Techniques
- D 4044-91 Test Method (Field Procedure) for Instantaneous Change in Head (Slug Test) for Determining Hydraulic Properties of Aquifers.
- D 4318-84 Test Method for Liquid Limit, Plastic Limit, and Plasticity Index of Soils
- D 4428/4428M-91 Test Method for Cross-hole Seismic Testing
- D 4718-87 Practice for the Correction of Unit Weight and Water Content for Soils Containing Oversize Particles
- D 4829-88 Test Method for Expansion Index of Soils
- D 5299-99 Decommissioning of Groundwater Wells, Vadose Zone Monitoring Devices, Boreholes and Other Devices for Environmental Activities
- G 57-78 Method for Field Measurement of Soil Resistivity Using the Wenner Four-

Electrode Method (1984)

5.2.2 Government Technical Publications

Government engineering and technical manuals should be used in conjunction with the ASTMs for accomplishing foundation design as applicable for the project features.

Design manuals (DM), Engineer Manuals (EM), Technical Manuals (TM) and Technical Instructions (TI) to be used by the geotechnical discipline include but are not limited to the following:

DM-1110-1-1	Engineering and Design Geotechnical Manual for Surface and Subsurface Investigations (USACE South Atlantic Division manual)
EM 1110-1-1804	Geotechnical Investigations
EM 1110-1-1-1904	Settlement Analysis
EM 1110-1-1-1905	Bearing Capacity of Soils
EM 1110-1-2908	Rock Foundations
EM 1110-2-1902	Slope Stability
EM 1110-2-1906	Laboratory Testing
EM 1110-2-1913	Design and Construction of Levees
EM 1110-2-2906	Design of Pile Foundations
TM 5-818-1	Soils and Geology Procedures for Foundation Design of Buildings and Other Structures (Except Hydraulic Structures)
TM 5-818-5	Dewatering and Groundwater Control
TM 5-818-7	Foundations in Expansive Soils
TM 5-818-8	Engineering Uses of Geotextiles
TI 800-01	Design Criteria
TI-800-03	Design Build Instructions

See Chapter 3 Site Development and Chapter 9 Structural for additional publications to be used in the design of roads and buildings.

5.3 PROJECT DEFINITION (10-15%)

The Project Definition Submittal should have a geotechnical chapter that states the known general geology and physiology of the project site. The chapter should state the site's history and its status as a potential site of Hazardous and Toxic Waste (HTW) contamination. The chapter should identify any available and relevant existing subsurface data at the site and state whether additional subsurface investigation is required for the

design of the project. The chapter should describe and state the status of any ongoing subsurface investigation. The chapter should identify the entities responsible for providing any required additional subsurface investigation, the Geotechnical Report, and for providing the geotechnical specifications.

5.4 SUBSURFACE INVESTIGATION AND GEOTECHNICAL REPORT

5.4.1 Subsurface Investigation

Planning for, and implementation of, the subsurface investigation shall be performed by the entity tasked with performing the subsurface.

5.4.1.1 Planning

The subsurface investigation should be planned considering the regional geology, existing subsurface information at the site or its vicinity, the site history, and locations of project features. The history of the site should be considered to assess whether subsurface conditions may have changed since existing subsurface information was obtained. A preliminary boring location plan showing proposed locations of borings, test pits, resistivity tests, etc. should be prepared. Drilling instructions detailing the type and required depths of borings should be prepared. The method of locating borings should be planned and coordinated.

5.4.1.2 Boring Locations and Elevations

- (a) If the designer is tasked to perform the subsurface investigation, accurate determination of locations and elevations of borings including any required surveys shall be the designer's responsibility unless specifically otherwise stated in his statement of work. Locations of borings at their as-drilled locations shall be documented both using coordinates on the drilling logs and showing the locations on the boring location map. Datum and units of location coordinates and elevations shall be indicated on the boring logs and boring location map. All changes to proposed boring locations at any stage should be documented.
- (b) When topographic survey of site is conducted after preparation of preliminary boring location map and either before or concurrently with subsurface investigation, generally a copy of boring location map should be provided to surveyor and the surveyor's statement of work should require placement of stakes marked with boring name and ground surface elevation at the proposed boring locations and that coordinates and ground surface elevations at the staked locations be provided.
- (c) If borings on land are not staked out in advance by survey and if features, spot elevations, and elevation contours of sufficient detail and accuracy are shown on the boring location map, the proposed boring locations may be staked out based on offset distances from the boring locations to other surveyed features shown on the boring location map and ground surface elevations may be estimated from the elevations shown on the map. Otherwise, a new survey should be conducted for the purpose of staking out the borings and determining the coordinates and elevations at these locations.
- (d) For offshore borings in water too deep or rapid to stake out, location survey measurements shall be made while and after navigating to the required location. Ground surface elevations typically should be determined by correlation of water depth measurements at the boring locations and concurrent gage readings of the water

levels. The water depth, date, and time of measurement should be recorded on the boring log for all such water depth measurements. A minimum of two water measurements should be made, one at the beginning of the boring and a second at the end. If the sampling platform is influenced by the tide or is unstable, additional measurements shall be made and recorded periodically as necessary to calculate the correct sampling depths.

- (e) The method of locating borings shall be described in the Geotechnical Report.

5.4.1.3 Drilling and Sampling

A copy of the preliminary boring location plan and drilling instructions containing specific requirements for drilling, sampling, backfilling of boreholes, disposition of samples, etc. should be provided in the drilling contractor's or subcontractor's statement of work. Right-of-entry and drilling permits shall be obtained where required. No drilling shall be performed prior to obtaining utility clearance.

5.4.1.4 Laboratory Testing

Laboratory testing shall be performed on selected samples as needed to accurately characterize the subsurface conditions at the site and to determine parameters for design analysis. Tests shall be appropriate for the type of materials encountered in the borings.

5.4.1.5 Abandonment of Bore Holes

All soil or core borings shall be abandoned in accordance with the following:

- (a) Each hole shall be measured for depth before it is sealed to ensure freedom from obstructions that may interfere with effective sealing operations. Any obstruction shall be cleared before proceeding with borehole sealing operations.
- (b) All borings in a Karst terrain area shall be sealed by backfilling with concrete, grout, neat cement, or a bentonite/cement mixture.
- (c) All other borings greater than 12 feet deep shall be sealed by backfilling with concrete, grout, neat cement, or a bentonite/cement mixture.
- (d) All other borings 12 feet or less in depth shall be sealed by backfilling with concrete, grout, neat cement, or a bentonite/cement mixture or filled with soil or cuttings from the hole, tamped in place with the auger or bit.
- (e) All grout materials shall be pumped into the borehole from the bottom to the top by pressure grouting with the positive displacement method (tremie method).
- (f) Each grouted boreholes shall be given time to allow the backfill material to settle in the borehole. If the backfill material settles 2-feet or more below ground surface (BGS) then the contractor shall place more backfill material in the borehole to the top. If the backfill material is less than 2-feet BGS than the contractor may backfill the borehole using compacted native material.

5.4.2 Geotechnical Report

- (a) The Geotechnical Report shall be prepared by or under the direction of the geotechnical engineer or geologist responsible for the subsurface investigation. The Geotechnical Report shall present the results of the subsurface investigation including laboratory testing and shall offer recommendations for the design of structure foundations, pavements, and other geotechnical features. Specialty field tests such as pH measurements, resistivity tests, and percolation tests shall be included for use in design, if appropriate. The designer shall be responsible for selecting the structure foundation type based on the recommendations offered in the Geotechnical Report. The Geotechnical Report shall contain all the required data to design the foundation, to include items such as construction and permanent dewatering, pile driving, slope stabilization, etc. The geotechnical investigation shall adequately characterize the site geology and hydrogeology and shall provide all geotechnical data required to complete the project design. The Geotechnical Report may be submitted for review prior to the conventional submittal dates if time permits. The narrative portion of the Geotechnical Report and any sections or profiles containing interpretations of subsurface data should be included with design submittals but should not be included in contract documents.
- (b) The Geotechnical Report Checklist (**Exhibit 5-6**) should be used to verify that the report is complete regarding the items described in the checklist.

5.4.2.1

Structures

- (a) The Geotechnical Report shall recommend the type of foundation system to be used for each primary structure in the project. The designer shall prepare earthwork specifications for the structures. See requirements for shallow foundations and deep foundations below, and Chapter 9 STRUCTURAL for further design requirements.
- (b) If shallow foundations are recommended, the Geotechnical Report shall recommend the allowable bearing pressure, the depth of placement and bearing elevations for the footings, minimum footing widths, and minimum footing embedment depths. Requirements for measures such as soil stabilization, removal and replacement of unsatisfactory materials, surcharge fills, and capillary water barriers shall be addressed in the Geotechnical report if these measures are needed. The designer shall size all footings, grade beams, slabs, etc., utilizing the recommendations and restrictions presented in the Geotechnical Report. The designer shall be responsible for obtaining all geotechnical data required for the design of each type of foundation during the subsurface investigation if tasked to perform the subsurface investigation.
- (c) If deep foundations are recommended, the Geotechnical Report shall provide recommendations for the type of deep foundation system to be used (piling, caissons, etc.), elevation of top of sound rock if applicable, the size and length of the piling or caissons, required tip elevations, and the allowable bearing capacity. The designer shall determine the number of piles or caissons, actual spacing, and the pile cap design. The number and location of test piles and load tests to be specified in the construction contract should be recommended in the Geotechnical report.

5.4.2.2

Dewatering Systems

- (a) Groundwater levels at borings, soil classifications, and sieve analysis of aquifer samples shall be routinely conducted and included in the Geotechnical Report and

shall be used to determine routine requirements for temporary dewatering systems. More specialized investigation such as piezometer installation, field pumping tests, laboratory permeability tests may be used and are advisable if a large dewatering effort will be required. Based on the results of the geotechnical investigation, the designer shall determine project dewatering requirements. All the required information necessary for the design of the system (hydrogeologic data, geotechnical analyses of sediments, aquifer properties such as hydraulic conductivity, transmissivity, storage coefficient, etc.) shall be collected during the geotechnical investigation and presented in the Geotechnical report. The use of slug tests to determine aquifer characteristics shall not be acceptable for dewatering designs.

- (b) Short-term construction dewatering due to poor surface drainage, precipitation, or short duration work at or near the water table is generally considered a contractor responsibility. Using information from the Geotechnical Report, the designer should alert the contractor to any known conditions that shall require dewatering. When temporary construction dewatering shall be required due to a consistently high-water table or the effects of underlying artesian aquifers, the designer shall design and present a dewatering plan in sufficient detail that the contractor can bid on and install the dewatering system.
- (c) Design of long-term or permanent dewatering systems, including selection of well screen slot sizes, screen lengths, discharge pipe sizes, installation methods, etc. shall be the responsibility of the designer.

5.4.2.3 Earth Liners

The geotechnical investigation and report should provide the designer with the overall geologic conditions, the in situ and constructed permeabilities that can be obtained using native materials and stabilizing agents, liner types and thicknesses, and slope stabilization requirements. The designer shall be required to apply for all necessary permits. As part of the permitting process, he shall be required to determine the classification of the material to be contained, the permeability necessary to contain the material, and the size and functional configuration of the containment area. No earth liners shall be permitted when material to be retained has a pH below 5.

5.4.2.4 Cathodic Protection and Grounding Systems

The geotechnical investigation and report should include all pH tests, salinity tests, resistivity measurements, etc., required to design corrosion control and grounding systems. The raw field data shall be provided in the Geotechnical Report without interpretation or recommendations. The designer shall design all corrosion control and grounding systems required for the project and shall advise Eglin immediately if additional field data is required.

5.4.2.5 Permanent Water Well Design and Construction If required by his scope of work, the designer shall be required to determine the location of the well, verify the flow requirements, verify future demands based on facility estimates, and determine the pump size and type. All drilling and/or well construction shall be performed by a properly licensed driller if required by local or State regulations. The permanent well design shall be based on data collected from the installation and/or aquifer testing of a pilot well. Test well borings shall be continuously sampled and visually logged by a qualified geologist. Additionally, the borehole shall be geophysically logged to verify the visual log. Sediment samples from the anticipated production zone(s) shall be analyzed for grain size distribution and any other

required parameters to assist in the design of the well. The completed design shall specify casing sizes and lengths, grouted intervals, well screen slot size(s), screen length, filter pack gradation, centralizer locations, and testing requirements to ensure the straightness and plumbness of the borehole and completed well. All unused test holes or wells shall be grouted from the bottom to the top by pressure grouting with the positive displacement method (tremie method).

5.4.2.6 Pavements

The Geotechnical Report shall recommend for pavement subgrades the allowable design CBR and modulus of subgrade reaction parameters with the required compaction effort. Guidance shall be offered on the types of base course materials available in the area and design strengths. The designer shall prepare all earthwork specifications for pavement subgrades. The designer shall prepare all pavement material specifications with consultation from the Geotechnical Branch. See Chapter 3 titled SITE DEVELOPMENT, for deviations or exceptions.

5.4.2.7 General Earthwork and Special Features

The Geotechnical Report shall recommend undercutting requirements, fill and backfill placement procedures, types of compaction equipment to be used, and outline earthwork procedures for special features such as retaining walls, embankment construction, earth covering of structures, basements, buried and mounded tanks, utilities, etc. The designer shall consult with the geotechnical engineer or geologist responsible for the subsurface investigation, or his office in his absence, in the design and preparation of specifications for any special features with geotechnical aspects that are not included or adequately described in the Geotechnical Report.

5.4.3 Boring Logs

- (a) Logs of borings shall be provided as an appendix to the Geotechnical Report, design analysis, and contract specifications. ENG Form 1836 and ENG Form 1836A, modified to 8.5-inch x 11-inch page size as shown in **Exhibits 5-5** and **5-6**, shall be used for the first page and for continuation pages respectively for boring logs unless otherwise approved by Eglin PM. Adobe Acrobat Portable Document Format (PDF) files named “logs.pdf” and “tests.pdf” shall be provided for the appendices. General Notes, Soil Classification Legend, Rock Classification Legend, if applicable, and Abbreviations pages shall be included at the beginning of the logs.pdf file, followed by the boring location map, if applicable, and followed by the boring logs. For subsurface investigations conducted by the designer, his subcontractor, or by a contractor under Eglin’s direction, the designer or contractor shall, in addition to the required PDF files, provide complete and accurate boring log data in comma-separated-value (CSV) files.

5.4.4 Boring Location Map

Locations of borings, test pits, monitoring wells and piezometers shall be shown on boring location map(s) in the appendix with boring logs in file logs.pdf, on civil site plans, or in both the logs.pdf file and on civil site plans. Boring location maps shall be clearly legible when printed at 8.5-in. x 11-in. size if included in the log’s .pdf file.

5.4.5 Laboratory Test Data

Laboratory test data shall be provided as an appendix to the Geotechnical Report, design analysis, and contract specifications. Laboratory test data shall be provided in a Portable Document File (PDF) file named "tests.pdf". The designer or contractor shall, in addition to the required PDF files, provide laboratory test data in comma-separated values (CSV).

5.5 CONCEPT DESIGN (30-35%)

5.5.1 Design Analysis

- (a) Incorporate recommendations stated in the Geotechnical Report into the design.
- (b) Provide geotechnical design calculations using parameters outlined in the Report and include a copy of the Report in the design analysis.
- (c) Notify the Geotechnical branch of any conflicts between the Geotechnical Report and concept design. If the topographic surveys are to be performed by the designer, then an electronic file copy in a DGN format of the survey must be sent to the entity performing the geotechnical investigation, as soon as possible but no later than the date for the submittal of the 35% design.
- (d) Include boring logs and laboratory test data as an appendix.

5.5.2 Design Drawings

- (a) Locate soil borings, test pits, monitoring wells and piezometers on the civil site plan. Add the appropriate symbol to legend.
- (b) Add note to civil site plan: "For logs of borings and test data, see __." and reference the appendix that includes boring logs and test data.

5.6 INTERIM DESIGN (50-65%)

- (a) Comply with the accepted comments on the concept design.
- (b) Perform any Concept Design tasks that were not completed.
- (c) Provide redlined marked up specifications in accordance with Chapter 2, SPECIFICATIONS.

5.7 FINAL DESIGN (UNREVIEWED 100%)

5.7.1 General

- (a) Comply with comments on the interim review. Perform any Concept Design or Interim Design tasks that were not completed.
- (b) Provide redlined marked up specifications if not provided at the Interim submittal. Provide final edited specifications if an Interim submittal was prepared in accordance with Chapter 2, SPECIFICATIONS.
- (c) Include boring logs and laboratory test data as an appendix of the specifications. Show locations of borings, test pits, monitoring wells and piezometers either on a

page in the appendix with boring logs (file logs.pdf) and/or on civil site plans.

- (d) Use the Plans and Specifications Submittal Checklist (**Exhibit 5-6**) to verify that the submittal is complete regarding the items described in the checklist.

5.7.2 Design Analysis

- (a) Incorporate recommendations stated in the Geotechnical Report into the design.
- (b) Provide foundation design calculations using parameters outlined in the Report, and include a copy of the Geotechnical Report in the design analysis.
- (c) Identify and resolve any conflicts between the Geotechnical Report and the design. Contact the author of the Geotechnical Report for assistance in resolving such conflicts if needed or if the Geotechnical Report needs to be modified.

5.7.3 Design Drawings

- (a) Locate soil borings, test pits, monitoring wells and piezometers on civil site plan. Add the appropriate symbol to legend.
- (b) Add note to civil site plan: "For logs of borings and test data, see __." and reference the appendix that includes boring logs and test data.

5.7.4 Specifications

The designer for A-E designed projects shall provide specifications required for geotechnical aspects of the project. If applicable, specifications provided by the geotechnical entity should include, but not be limited to:

31 00 00	Earthwork
31 00 00.10 36	Earthwork
31 31 16	Soil Treatment for Subterranean Termite Control
31 00 00.15 36	Excavation, Filling and Backfilling for Buildings
31 00 00.16 36	Excavation, Trenching, and Backfilling for Utilities Systems

If the UFGS Section 31 00 00 is used as the only earthwork specification, it shall be edited and care shall be taken to ensure all applicable aspects of earthwork (for site work, at buildings, and for utilities) are covered and those not applicable removed. Other specifications related to geotechnical aspects of the project should be provided as applicable. Other UFGS Unified Facilities Guide Specifications can be found in SpecsIntact.

5.8 READY TO ADVERTISE (REVIEWED 100%)

- (a) Comply with comments on the final design review.
- (b) Include, or verify that they are included, any drawings and specifications in the Index of Drawings and the Table of Contents for specifications.
- (c) Include boring logs and laboratory test data (PDF files named logs.pdf and tests.pdf) as appendices of the specifications.
- (d) Do not include the narrative portion of the Geotechnical Report or any sections or profiles containing interpretations of subsurface data in contract drawings or specifications.

Exhibit 5-1
Boring Log – General Notes









APPENDIX 'A' – LOGS OF BORINGS AND TEST DATA

GENERAL NOTES:









1. GROUNDWATER DEPTHS OR ELEVATIONS SHOWN ON THE BORING LOGS REPRESENT GROUNDWATER ENCOUNTERED ON THE DATES SHOWN. ABSENCE OF GROUNDWATER DATA ON CERTAIN BORINGS IMPLIES THAT NO DATA IS AVAILABLE, BUT DOES NOT NECESSARILY MEAN THAT GROUNDWATER WILL NOT BE ENCOUNTERED AT THE LOCATIONS. GROUNDWATER ELEVATIONS VARY AND SEEPAGE ABOVE THE DEPTHS OR ELEVATIONS SHOWN CAN BE EXPECTED AT ANY TIME.
2. WHILE THE BORINGS ARE REPRESENTATIVE OF SUBSURFACE CONDITIONS AT THEIR RESPECTIVE LOCATIONS AND FOR THEIR RESPECTIVE VERTICAL REACHES, LOCAL MINOR VARIATIONS IN CHARACTERISTICS OF THE SUBSURFACE MATERIALS ARE ANTICIPATED AND, IF ENCOUNTERED, SUCH VARIATIONS WILL NOT BE CONSIDERED AS DIFFERING MATERIALLY FROM THE DESCRIPTION SHOWN WITH THE LOGS OR PROFILES.
3. SOILS ARE CLASSIFIED IN ACCORDANCE WITH THE UNIFIED SOIL CLASSIFICATION SYSTEM, ASTM-D-2487, CLASSIFICATION OF SOILS FOR ENGINEERING PURPOSES.
4. DRIVING RESISTANCES (BLOW COUNTS OR N VALUES) ARE DETERMINED WITH A STANDARD SPLIT SPOON SAMPLER (1-3/8" I.D.) AND A 140-LB DRIVING HAMMER WITH A 30" DROP UNLESS OTHERWISE NOTED ON THE BORING LOGS. N VALUES SHOWN NUMERICALLY ON THE LOGS ARE THE SUM OF BLOWS FOR THE LOWER TWO OF THREE 0.5-FOOT DRIVES THAT MAKE UP THE 1.5-FOOT STANDARD PENETRATION TEST, EXCEPT WHEN REFUSAL OCCURS. REFUSAL OF THE SPLITSPOON IS DEFINED AS 50 BLOWS IN LESS THAN A 0.5-FOOT DRIVE. REFUSAL IS SHOWN ON THE LOGS AS INDICATED IN THE FOLLOWING EXAMPLES:
 - 50/0.3' – INDICATES 50 BLOWS (REFUSAL) AFTER 0.3' PENETRATION IN THE FIRST DRIVE.
 - 20, 50/0.2' – INDICATES 20 BLOWS IN THE FIRST DRIVE AND REFUSAL AFTER 0.2' PENETRATION IN THE SECOND DRIVE.
 - 20, 85/0.8' – INDICATES 20 BLOWS IN THE FIRST DRIVE, 35 BLOWS IN THE SECOND DRIVE AND REFUSAL (50 BLOWS) AFTER 0.3' PENETRATION IN THE THIRD DRIVE.
5. "MAX SIZE" OF GRAVEL OR ROCK FRAGMENTS SHOWN ON THE BORING LOGS REPRESENTS THE MAXIMUM SIZE OF MATERIAL RECOVERED IN THE DRIVE SAMPLER AND/OR CORE BARREL OR OBSERVED FROM AUGERING UNLESS OTHERWISE NOTED. NOTE THAT THE MAXIMUM LOGGED SIZE OF GRAVEL OR ROCK FRAGMENTS IS LIKELY TO BE SMALLER THAN THE MAXIMUM SIZE OF THE IN-PLACE MATERIAL, ESPECIALLY WHEN THE MAXIMUM LOGGED SIZE IS MORE THAN APPROXIMATELY ONE-HALF THE DIAMETER OF THE DRIVE SAMPLER OR CORE BARREL, OR MORE THAN ONE-THIRD THE DIAMETER OF THE AUGER.
6. CLASSIFICATIONS SHOWN IN COLUMN D OF THE BORING LOG FORM ARE THE DRILLING INSPECTOR'S FIELD VISUAL CLASSIFICATION OF SAMPLES UNLESS OTHERWISE INDICATED ON THE LOG. WHEN AVAILABLE, LABORATORY CLASSIFICATIONS OF SAMPLES ARE SHOWN IN COLUMN G (REMARKS COLUMN) UNLESS OTHERWISE INDICATED.

Exhibit 5-2
Boring Log - Soil Classification Legend

COARSE-GRAINED SOILS - MORE THAN HALF OF MATERIAL IS LARGER THAN NO. 200 SIEVE SIZE

GW		WELL GRADED GRAVELS OR GRAVEL-SAND MIXTURES, LITTLE OR NO FINES
GP		POORLY GRADED GRAVELS OR GRAVEL-SAND MIXTURES, LITTLE OR NO FINES
GM		SILTY GRAVELS, GRAVEL-SAND-SILT MIXTURES
GC		CLAYEY GRAVELS, GRAVEL-SAND-CLAY MIXTURES
SW		WELL GRADED SANDS OR GRAVELLY SANDS, LITTLE OR NO FINES
SP		POORLY GRADED SANDS OR GRAVELLY SANDS, LITTLE OR NO FINES
SM		SILTY SANDS, SAND-SILT MIXTURES
SM-H		SAME AS ABOVE WITH HIGH LIQUID LIMIT
SC		CLAYEY SANDS, SAND-CLAY MIXTURES
SC-H		SAME AS ABOVE WITH HIGH LIQUID LIMIT

FINE-GRAINED SOILS - MORE THAN HALF OF MATERIAL IS SMALLER THAN NO. 200 SIEVE SIZE

ML		INORGANIC SILTS AND VERY FINE SANDS, ROCK FLOUR, SANDY SILTS OR CLAYEY SILTS WITH SLIGHT PLASTICITY
MH		INORGANIC SILTS, MICACEOUS OR DIATOMACEOUS FINE SANDS OR SILTY SOIL, PLASTIC SILTS
OL		ORGANIC SILTS AND ORGANIC SILT-CLAYS OF LOW PLASTICITY
OH		ORGANIC CLAYS OF MEDIUM TO HIGH PLASTICITY, ORGANIC SILTS
CL		INORGANIC CLAYS OF LOW TO MEDIUM PLASTICITY, GRAVELLY CLAYS, SANDY CLAYS, SILTY CLAYS, LEAN CLAYS
CH		INORGANIC CLAYS OF HIGH PLASTICITY, FAT CLAYS
PT		PEAT AND OTHER HIGHLY ORGANIC SOILS
		BITUMEN, ASPHALT, OR ASPHALTIC CONCRETE
		CONCRETE

NOTE: DUAL CLASSIFICATIONS, E.G. SP-SM, GP-GM, ML-CL AND SM-SC, ARE SHOWN BY PLACING BOTH SYMBOLS SIDE BY SIDE.

Sample
Boring Log - Rock Classification Legend



SANDSTONE



RHYOLITE



SILTSTONE OR CLAYSTONE



BASALT



SHALE



GRANITE



CEMENTED SHALE



GNEISS



LIMESTONE



CONGLOMERATE



DOLOMITE



CHERT



SCHIST



COAL



PHYLLITE



SHELL, SHELL FRAGMENTS,
OR SHELL-SOIL MIXTURE
CONSISTING MOSTLY OF SHELL



QUARTZITE



VOID (CAVITY,
OPEN JOINT, ETC.)



NOT SAMPLED OR
SAMPLE NOT RECOVERED

Exhibit 5-3
Boring Log – Abbreviations

ABBREVIATIONS

@ AT
 ACCUM ACCUMULATED
 ALT ALTERNATING
 ANG ANGULAR
 APPROX. APPROXIMATE (LY)
 ARGIL ARGILLACEOUS
 AUG AUGER
 AVG AVERAGE
 B.A. BASE OF ALLUVIUM
 B.I. BREAKAGE INTERVAL
 B.O.H. BOTTOM OF HOLE
 BBL BARREL
 BDD BED (ED) (DING)
 BDR BEDROCK
 BENT. BENTONITIC
 BGE BEIGE
 BKY BLOCKY
 BL BLACK (ISH)
 BLD BOULDER
 BR BROWN (ISH)
 BRECC. BRECCIATED
 BRK BROKEN, BREAKAGE
 C.D. CORRECTED DEPTH
 CAL CALCITE, CALCAREOUS
 CARB CARBONACEOUS
 CAV CAVITY
 CBL COBBLE
 CEM CEMENT
 CHT CHERT
 CIRCLE. CIRCULATION
 CLY CLAYEY
 CMT'D CEMENTED
 CNTR (S) CONCENTRATION (S)
 COMP COMPACT
 CONC CONCRETE
 CONCR CONCRETIONS
 CONGL CONGLOMERATE
 CONT. CONTINUED
 CR'D CRUSHED
 CRM CRUMBLY
 CSE COARSE
 CTD COATED
 D. DENSE
 d. DEPTH
 D.A. DRILL ACTION
 D.T. DRILL TIME
 D.W.L. DRILL WATER LOSS
 D.W.R. DRILL WATER RETURN
 DECOM DECOMPOSED
 DIAG DIAGONAL
 DIS. DISSEMINATED
 DK DARK
 DOL. DOLOMITE, DOLOMITIC
 DRL DRILLING
 DSTG DISINTEGRATE (D)
 EL ELEVATION
 ENC ENCOUNTERED
 EST ESTIMATE (D)
 EXCL EXCLUDING
 EXTR EXTREMELY
 F. FINE (LY)
 F.R. FLUID RETURN
 F/T FISHTAILED
 FE IRON
 FERR FERRUGINOUS
 FIS FISSILE
 FLD FILLED
 FM FORMATION

ABBREVIATIONS

FOLIA. FOLIATION
 FOS FOSSIL (IFEROUS)
 FRAC FRACTURE
 FRAG FRAGMENT (S)
 G.W. GROUNDWATER
 GEN. GENERALLY
 GLAU GLAUCONITE (ITIC)
 GR GRAY (ISH)
 GRA GRAIN (ED)
 GRAD GRADATIONAL
 GRN GREEN (ISH)
 GRT GROUT
 GVL GRAVEL (LY)
 GYP GYPSUM
 H/A HIGH ANGLE
 H/B HAMMER BREAK
 HD HARD
 HI HIGH (LY)
 HLD HEALED
 HMR HAMMER
 HOR HORIZONTAL
 HYD HYDRAULIC
 INCL INCLUDING (ED)
 INDT INDURATED
 INIT INITIAL (LY)
 INTBDD INTERBED (DED)
 INTLAM INTERLAMINATED
 IRR IRREGULAR (LY)
 JT'S JOINT'S
 JTD JOINTED
 L.C. LOSE CORE
 L.D.W. LOST DRILL WATER
 L/A LOW ANGLE
 LAB. LABOR
 LAM LAMINATED, LAMINA (NAE)
 LAY. LAYER
 LEA LEACHED
 LGE LARGE
 LIG LIGNITIC
 LIT LITTLE
 LL LIQUID LIMIT
 LN. (S) LENSE (S)
 LO LOOSE
 LS LIMESTONE
 LT LIGHT
 MAS MASSIVE
 MAX MAXIMUM
 MECH MECHANICAL
 MED MEDIUM
 MIC MICACEOUS
 MIN MINIMUM
 MINR MINERALIZED (IZATION)
 MIX. MIXTURE
 MOD MODERATE (D)
 MOT MOTTLED (ING)
 MST MOIST
 MTL MATERIAL
 MTX MATRIX
 N/A NOT APPLICABLE
 N/E NOT ENCOUNTERED
 N/R NO RECOVERY
 NOD. NODULE
 NUM NUMEROUS
 OB OVERBURDEN (UNCLASSIFIED)
 OBS OBSERVED
 OCC OCCASIONAL (LY)
 OOL OOLITE, OOLITIC
 OP OPEN (ED)
 OR ORANGE

Sample
Boring Log – Abbreviations

ABBREVIATIONS

ORG	ORGANIC
P.S.I.	POUNDS/SQ. IN.
P.T.	PRESSURE TEST
PART.	PARTIALLY
PCS	PIECES
PETRO	PETROLEUM. PETROLIFEROUS
PHOS	PHOSPHATE (PHOROUS)
PI	PLASTICITY INDEX
PIT	PIT (TED) (TING)
PKT (S)	POCKET (S)
PL	PLASTIC LIMIT
PLA	PLATY
PLAS	PLASTIC
PLN	PLANE
PNK	PINK
PR	POORLY
PRED	PREDOMINATED
PRESS	PRESSURE
PROB	PROBABLE (ABILITY)
PTC	PARTICLES
PTG	PARTING
PUR	PURPLE
QTZ	QUARTZ
QTZE	QUARTZITE
R.O.D.	ROCK QUALITY DESIGNATION
RBL	RUBBLE
RD	RED (DISH)
REC	RECOVERY
RECEM	RECEMENTED
RND	ROUND (ED)
RTS	ROOTS
S/S	SPLIT
SAP	SAPROLITE
SAT	SATURATED
SCAT.	SCATTEREDLY
SCH (S)	SCHIST (OS)
SD	SAND
SDY	SANDY
SH	SHALE
SI	SILT
SIS	SILTSTONE
SIY	SILTY
SL	SLIGHT (LY)
SLCES	SILICEOUS
SLICK.	SLICKENSIDE
SML	SMALL
SO	SOFT
SOL	SOLUTION (ED) (ING)
SPG	SPECIFIC GRAVITY
SPT	STANDARD PENETRATION TEST
SPT	STANDARD SPLITSPOON
SS	SANDSTONE
ST	STRAIN (ED) (ING)
STF	STIFF
STR	STRUCTURE
STRG	STRINGER
STYL	STYLOLITE (OLITIC)
SUR	SURFACED
T.F.R.	TOP OF FIRM ROCK
T.O.R.	TOP OF ROCK
T.S.R.	TOP OF SOUND ROCK
TEXT.	TEXTURE
THK	THICK
THN	THIN
TI	TIGHT
TN	TAN (NISH)
TR	TRACE
TRP	TRIPOLI

ABBREVIATIONS

UD	UNDISTUBED
UL	UNACCOUNTABLE LOSS
UNACC	UNACCOUNTABLE
UNWEA	UNWEATHERED
V/	VERY
VERT	VERTICAL
VGY	VUGGY
W.C.	WATER CONTENT
W.L.	WATER LEVEL
W/	WITH
W/H	WEIGHT OF HAMMER
W/R	WEIGHT OF ROD
WD	WOOD
WEA	WEATHERED
WG	WEIGH
WHT	WHITE
X-BDD	CROSS-BEDDED
XL	CRYSTAL
XLN	CYRSTALLINE
YEL	YELLOW

Exhibit 5-4: Boring Log – ENG Form 1836

DRILLING LOG			DIVISION		INSTALLATION		Hole No.		SHEET OF SHEETS		
1. PROJECT					10. SIZE AND TYPE OF BIT						
2. LOCATION (Coordinates or Station)					11. ELEVATION DATUM						
3. DRILLING AGENCY					12. MANUFACTURER'S DESIGNATION OF DRILL						
4. HOLE NO. (As shown on drawing title and file number)					13. TOTAL NO. OF OVER-BURDEN SAMPLES TAKEN		DISTURBED		UNDISTURBED		
5. NAME OF DRILLER					14. TOTAL NUMBER CORE BOXES						
6. DIRECTION OF HOLE <input type="checkbox"/> VERTICAL <input type="checkbox"/> INCLINED DEG. FROM VERTICAL					15. ELEVATION GROUNDWATER		16. DATE HOLE		STARTED		COMPLETED
7. THICKNESS OF OVERBURDEN					17. ELEVATION TOP OF HOLE						
8. DEPTH DRILLED INTO ROCK					18. TOTAL CORE RECOVERY FOR BORING						
9. TOTAL DEPTH OF HOLE					19. SIGNATURE OF INSPECTOR						
ELEVATION a	DEPTH b	LEGEND c	CLASSIFICATION OF MATERIALS (Description) d			% CORE RECOVERY OR W.C. e	BOX OR SAMPLE NO. f	REMARKS (Drilling time, water loss, depth of weathering, etc., if significant) g			

Exhibit 5-5: Boring Log – ENG Form 1836A

DRILLING LOG (Cont Sheet)			ELEVATION TOP OF HOLE		Hole No.	
PROJECT			INSTALLATION			SHEET OF SHEETS
ELEVATION a	DEPTH b	LEGEND c	CLASSIFICATION OF MATERIALS (Description) d	% CORE RECOVERY OR W.C. e	BOX OR SAMPLE NO. f	REMARKS (Drilling time, water loss, depth of weathering, etc., if significant) g

ENG FORM 1836-A (Facsimile)

PROJECT

HOLE NO.

Exhibit 5-6: Geotechnical Report Checklists

1. Describe general site access with respect to mobility or drilling or other test equipment. Field sketches of existing utilities, fences, walkways and pavements should be made to compare to the topography map.

2. Generally describe the site topography and note all the topographic features that effect the project.

3. Describe the slope of the ground surface and delineate all drainage channels and any previous cut and fill or erosion.

4. Describe existing structures, pavements, or other obstructions and the procedures for demolition.

5. Fully describe the results of the subsurface investigation and any laboratory testing and its impacts on constructing the project.

6. GENERAL SCOPE:

- a. Results of subsurface investigation & testing
- b. Recommendations based on (a) above.

7. DETAIL INFORMATION:

a. Description of structure(s)

- (1) Written general description
- (2) Type of construction contemplated.
- (3) Size and Height
- (4) Finished Floor elevation; Elevation of existing ground
- (5) Type of Foundation recommended
- (6) Approximate load (s)
- (7) Special Features affecting Foundation Design
- (a) Water table, or history of dewatering or seepage problems
- (b) Condition or history of nearby buildings
- (c) Analyze whether dewatering would cause settlement of adjacent structures
- (d) Location of fills or dump areas near site, which may jeopardize foundation
- (e) Existing buried Utilities conflict with new foundations

b. Specific recommendations for foundation design and/or construction based on site features.

- (1) Topography
- (2) Surface Water
- (3) Groundwater
- (4) Subsurface soil conditions
- (5) Availability of borrow materials
- (6) Location & availability of spoil areas
- (7) Permitting actions required.

Geotechnical Report Checklists

c. Results and/or Recommendations for:

- (1) Bearing capacity
- (2) Piles (Type, length, capacity, type of installations)
- (3) Retaining Walls or basement walls
- (4) Mat Foundations
- (5) Slope Stability
- (6) Settlement
- (7) Permanent ground water drainage around or under structures
- (8) Construction Dewatering
- (9) Erosion control during and after construction

d. Revisions, additions, and/or deletions to the standard guide specs resulting from the foundation analysis.

- (1) Include a copy of the specification as it is proposed to be used.
- (2) Mention the major changes in the write-up and the reason for making them.

e. Design Calculations

- (1) Include applicable design calculations on settlement, bearing capacity, seepage, uplift, stability analysis, quantities, shrinkage, dewatering, etc.
- (2) Show formulas, assumptions and reference source

f. Site Plan

- (1) Show building road locations
- (2) Contours
- (3) Boring, test pit, infiltrometer locations
- (4) Locations of temporary & permanent surface water diversion measures
- (5) Location of buried utility line (existing & to be installed)

g. Logs of all boring and test pits in Adobe Acrobat Portable Document Format in file named logs.pdf. Make sure the logs have horizontal control to the nearest foot and vertical control to the nearest tenth of a foot shown for each log.

h. Results of all laboratory test data in Adobe Acrobat Portable Document Format in file named tests.pdf.

i. Results of all boring log and laboratory test data in CSV files as specified.

j. Detailed Dewatering design, if it is to be a major foundation cost.

Exhibit 5-7
Plans and Specifications Submittal Checklist

GENERAL

1. Coordinate index of drawings with the title of each sheet.
2. Coordinate the title of the drawings with the title of the specifications.
3. Coordinate drawings for scale and dimension.
4. Reference related views and details.
5. Orientate all drawings and plan views by north arrow.
6. Clearly define limits of the contractor and owner's responsibility, i.e. Owner furnished - contractor installed equipment or materials, Owner furnished - owner installed equipment or materials, Contractor furnished - Contractor installed equipment or materials.
7. Proofread applicable sections of the specifications after typing.
8. Coordinate technical provisions terminology of the specifications for compatibility against the drawings.
9. Provide written responses to comments on the previous submittal. Check that the accepted comments have been incorporated.
10. Show haul routes, disposal areas, borrow areas, benchmarks, and all general type contractor information.
11. Check that boring logs and test data have been properly included as Adobe Acrobat Portable Document Files logs.pdf and tests.pdf for Appendix 'A' of the specifications. If provided by CESAM-EN-GG, verify that these files have been emailed to the specifications engineer for the project.

TECHNICAL

1. Check if allowable soil or rocks bearing values are shown on structural sheet.
2. Check logs of borings and test result for accuracy with respect to location, elevation, classification, water level, etc.
3. Check that previous accepted comments have been incorporated into drawings and/or specifications.

Chapter 6 - Landscaping, Irrigation, Planting and Turfing

6.1 GENERAL

6.1.1 Scope

Specific submittal and technical requirements for landscape, temporary irrigations, planting, and turfing are presented in this chapter as guidance for the development of plans and specifications. The quality of the design shall be comprehensive and shall be coordinated with pertinent aspects of the overall site development, the architecture of structures, and user requirements. The design shall be fully coordinated with other design disciplines including area drainage, exterior site lighting, site lighting which differentiates between pedestrian and parking, pedestrian circulation and parking, storm water treatment, and parking layout. The design shall address features such as berming, planting, temporary irrigation, site furniture, site amenities (signs, bicycle parking racks, etc.), recreation facilities or areas, visual barriers, and energy conservation through planting. Eglin AFB Approved Landscaping Plant list is provided in Eglin Architectural Compatibility Plan.

6.2 APPLICABLE PUBLICATIONS

The most recent editions of the following publications at Project Solicitation Issue Date (Advertise Date) shall be referenced and incorporated (as appropriate) in work prescribed in this manual.

U.S Army Corps of Engineers Technical Instructions (TI)

TI 800-01 Design Criteria

Unified Facilities Criteria (UFC)

UFC 3-210-02 Landscape Architecture, With Change 1

UFC 4-010-01 Minimum Antiterrorism Standards for Buildings

6.3 PROJECT DEFINITION (10-15%)

The project definition shall verify the minimum design requirements for the work being performed in the landscape and temporary irrigation plans. Specific boundaries, limits of the work being performed, shall be delineated to anticipate the level of development of the landscape and temporary irrigation plans. Each plan shall in turn be used to determine a preliminary cost estimate for the project. Specific use areas shall be located to determine the proper landscape treatment for those areas, from both the standpoint of material selection and functional use e.g. screening, canopy, color, enclosure etc. and/or turf, it shall also be communicated in the project definition.

6.4 CONCEPT DESIGN (30-35%)

6.4.1 Design Analysis

- (a) The landscape planting design narrative shall describe the conditions of the existing site, including an indication of existing plant materials that are to remain on site. Specific site problems related to proposed development and rationale for proposed plant locations shall be indicated. For the irrigation system, if applicable, the designers shall determine whether irrigation water will be supplied via potable water, shallow well, or grey water source, and describe the material to be used in the irrigation piping system, and the type of irrigation heads to be used in various

locations. The narrative shall also include a list of suggested types and sizes of plant materials, which are to be used, based upon the designated functional and visual criteria, and installation specific planting lists. The concept cost estimate for landscaping, planting, and turfing shall be based on quantities derived from generalized locations and listed types and sizes of plant material.

- (b) The concept cost estimate for the landscape irrigation system shall be coordinated with the conceptual landscaping, planting, and turfing plan to estimate the type and quantity of irrigation heads and zone control valves to be used, as well as estimated irrigation pipe sizes, and their linear feet of length, type of irrigation controller, and other system appurtenances.

6.4.2 Drawings

The overall design approach shall depict factors, which affect existing site features and influence subsequent design proposals. The concept drawings shall be prepared at a scale, which corresponds to the site layout and grading plans, and shall include reference coordinates, north arrows, graphic scales, and appropriate legends.

6.5 INTERIM DESIGN (50-65%)

6.5.1 Design Analysis

The descriptive narrative, list of materials and cost estimate shall be refined to correspond with the development of the preliminary landscaping and irrigation plans.

6.5.2 Drawings

- (a) The interim design submittal shall expand the concept design by development of an overall planting layout and shall include enlarged detail plans of specific areas, as needed, to clarify requirements. The proposed layout shall indicate shade trees, evergreen trees, flowering trees, shrub masses, etc., according to designated functional and visual locations of planting. A legend indicating size of plants recommended for each of the above categories shall be included. The preliminary design drawings and all subsequent plans shall indicate existing and proposed buildings, paved areas, signs, light standards, transformers, dumpster areas, storm drainage system, and other structures and utilities. If existing and proposed contours cannot be clearly indicated graphically on the plan, overlay of the drawings shall reveal that grades and elevations have been considered. Grassing limits, seeded or sodded, shall be clearly described in the contract documents.
- (b) Temporary irrigation systems are typically included in projects as a performance specification with the actual design being performed by the contractor. Therefore, irrigation plans shall clearly delineate all required design information such as the limits of area to be irrigated; zones where specific spray heads or bubblers are to be used; locations for equipment such as controllers, wells, tanks, etc., as applicable; protective casings under pavements to facilitate installation and/or fixture expansion; locations of existing piping and sprinkler heads connecting to an existing system; and the location of the water supply source that will be used to provide water service to the irrigation system. Prior approval is required for permanent irrigation systems.

6.5.3 Specifications

Provide redlined, marked-up specifications in accordance with Chapter 2, SPECIFICATIONS.

6.6 FINAL REVIEW (UNREVIEWED 100%)

6.6.1 Design Analysis

- (a) The descriptive narrative, list of materials and cost estimate shall be refined to correspond with the development of the preliminary planting and landscape irrigation plans.
- (b) The performance irrigation specification must include guidance that the complete irrigation system design calculations, which include pressures and required flow rates, shall be submitted for review and approval before system installation begins. If the irrigation system obtains its water supply from an existing potable water supply source, then the irrigation system must be designed and installed so as not to degrade the existing water system pressure to any building in excess of 10 psi. Current fire flow tests must be obtained and included in these design calculations. It shall be the responsibility of the Contractor to obtain the most recent and current fire flow tests available before beginning any work. If another water supply source is used, then design calculations on that source must be submitted for review and approval before system construction begins.

6.6.2 Specifications

Provide redlined, marked-up specifications if not provided in the Interim submittal. Provide final edited specifications if an Interim submittal was prepared in accordance with Chapter 2, SPECIFICATIONS.

6.6.3 Drawings

- (a) Final landscaping design drawings, indicating proposed plants by a (+) mark for the plant location and a circle which is scaled at approximately 2/3 the ultimate growth spread (diameter) of plants, shall include a complete schedule of plant materials indicating botanical and common names, plan symbols, quantities, sizes, condition furnished, and pertinent remarks. Final drawings shall also include the basic detail for the installation of tree, shrub, and ground cover planting, as well as any other applicable details for clarification of specific project requirements. Pertinent notes applicable to construction requirements, in addition to standard notes, shall be included. The design plan, plant schedule, details, notes, specifications, and subsequent cost estimates shall also correspond.
- (b) Irrigation system plans as described above shall be brought to completion and include detail drawings as needed to describe system performance. Final performance specification irrigation system design drawings shall be coordinated with the landscaping plan to provide adequate irrigation requirements/coverage to protect and maintain the health of all areas of plants, shrubs, and grassed areas. Pipes shall be run in sleeves under all paved areas. Locate ends of sleeves with 12-inch rebar. A system shall be selected for minimum maintenance and operational skill requirements, without waste of water, including the piping, valves, sprinkler heads, controller and wiring, and all other system appurtenances that help to make a complete and operable landscape irrigation system. The system selected shall be divided into zones and shall be automatically controlled. Rain sensors, as applicable, shall be incorporated into the irrigation system controller to minimize water waste. Bubbler irrigation shall

be used immediately adjacent to buildings to prevent staining from overspray.

6.7 READY-TO-ADVERTISE (REVIEWED 100%)

All final design drawings, specifications, and the design analysis and cost estimate shall have incorporated comments from the preceding review before submittal as Ready-To-Advertise.

6.8 TECHNICAL REQUIREMENTS

6.8.1 Design Criteria

(a) Designer Qualifications

- (1) The designer shall obtain and use the services of a qualified Landscape Architect who is registered in the State of Florida and is experienced in site planning and planting design. The person performing this work shall be thoroughly familiar with the referenced Technical Manuals, and specifications.
- (2) The landscape irrigation system shall be designed and installed by an experienced firm regularly engaged in this type of work. The designer/installer shall have a minimum three (3) years of successful experience with designing and installing this type of system. Guidance shall be included in the specifications for the contractor to submit approval evidence of these qualifications.

(b) Major Design Considerations

- (1) Design plans shall reflect user needs, simplicity of layout, proper scale and placing of materials, low maintenance considerations, and compatibility with adjacent surrounding and anti-terrorism/force protection requirements. Specified plant materials shall be readily available for purchase, require minimum maintenance, be suitable and tolerant to both the geographic locale and the specific site conditions, be the proper quantities selected for the surroundings, and be of sufficient size to give an immediate effect. The types and location of plant materials shall be utilized, as appropriate to the function and prominence of specific facilities, to define the functional use areas and circulation systems of the site layout; to provide open space buffers between land uses and within parking areas; to reinforce the orientation of buildings and the use of earth forms for energy conservation; to supplement erosion control; to provide screening; and to emphasize entrances to buildings. The aesthetic quality of planting design shall be supportive in providing visual continuity in the relationship between buildings, the site, and the surrounding environment.
- (2) If a performance specification is to be included for the irrigation system design, then that specification shall be written such that it can be used as a guide for the design and installation of a complete operating lawn irrigation system. This design and installation shall be the responsibility of the contractor. The piping design and layout shall be coordinated with the landscaping plan to provide irrigation for all areas of plants, shrubs, and grassing within the design boundaries. The system shall be divided into

zones and be automatically controlled. The sprinkler heads, laterals, control valves, and other related irrigation system appurtenances shall be in accordance with the requirements contained within the landscape irrigation performance specification. Sprinkler performance such as operating pressure, radius of throw, etc., shall be chosen as best fitted for the intended area to be irrigated. Provide the sprinkler system as a complete unit produced by a single acceptable manufacturer for all major components including sprinkler heads, valves, controller, and other accessories.

- (3) A minimum three foot (3') wide strip of solid sod shall be installed adjacent to all impervious surfaces within the limits of construction unless otherwise approved by the Contracting Officer (CO).

6.8.2 Site Investigation

A visit to the project site is recommended as a necessary aspect of initial concept development. Visual observation of the surrounding environment of Eglin, determination, where applicable, of the continuity between new construction planning and existing development and ascertainment of the types of recommended materials and maintenance practices are influential factors in the analysis of the site problems and the formulation of concept solutions.

6.8.3 Coordination

- (a) Interface with applicable construction drawings. Landscape planting and irrigation plans shall be coordinated with existing conditions and demolition plans, site layout, grading and drainage, utilities, architectural floor plans and elevations, and pertinent aspects of mechanical, plumbing, and electrical drawings for the locations of items such as compressors, fuel oil tanks, transformers, meters, light standards, and hose bibs.
- (b) User requirements. Coordination of base requirements shall be accomplished prior to initiation of design submittals. The designer shall consult with the local user and Eglin personnel to substantiate the extent of the design requirements and to provide planting proposals, which correspond with maintenance capabilities.

Chapter 7 - Water, Wastewater and Environmental Protection

7.1 GENERAL

The design of all domestic water and wastewater systems shall be in accordance with the current ASUS design requirements. Should any requirements listed below conflict with ASUS standards, ASUS standards shall govern.

7.1.1 National Environmental Protection Act (NEPA) Documentation

If the government has prepared any NEPA Documentation, i.e. Environmental Impacts Statement (EIS), Environmental Assessments (EA), or a Finding of No Significant Impact (FONSI), the designer shall prepare the design so that it is entirely compatible with all requirements of the NEPA documents.

To determine what NEPA Documentation is required, an AF Form 813 needed to be submitted prior to project starting. Within this request, any design plans and maps of locations should be provided. During the AF Form 813 review, environmental and safety subject matter experts will review this request and provide feedback and/or requirements for this project. Contact the 96 CEG Environmental Planning Office (aac.emsp.environmentalanalysis@us.af.mil) with any questions.

7.2 PROJECT DEFINITION (10-15%)

The project definition shall contain a narrative description and a water and sanitary site plan. Construction of new facilities and major expansions to existing water and wastewater systems must comply with the procedural requirements of the applicable permitting agency or agencies having approval authority. Each state also has a department for pollution control projects involving point discharges. All designs of water and wastewater systems should be coordinated with the appropriate regulatory agency at all stages of design.

7.2.1 Design Analysis

The narrative shall define the source of water for potable use and fire protection. The narrative shall also describe any pretreatment, treatment, and methods of wastewater disposal from the new facility.

7.2.2 Water and Sanitary Site Plan

The water and sanitary site plan shall show all existing water lines and sanitary sewers. The new water lines for building service and fire flow shall be shown from the point of connection to the existing water distribution system. All necessary valves, fire hydrants, ground storage tanks, pump stations, etc. shall be indicated. Building connections for wastewater shall be shown from the building to the existing sanitary sewer system or on-site treatment system. All necessary septic tanks, grease traps, oil/water separators, treatment plants, manholes, lift stations, force mains, etc. shall be shown. All pipe sizes shall be indicated. At this stage or earlier, the designer shall request a fire flow test(s) specifying exact hydrant locations required to flow and where residual pressure is to be measured. Request shall be furnished to the Project Manager.

7.3 CONCEPT DESIGN (30-35%)

7.3.1 Design Analysis

The design analysis shall be sufficiently complete to clearly show project requirements and utility support capacity. Prepare outline specifications as directed in Chapter 2, SPECIFICATIONS.

7.3.1.1 Water Supply Sources

The source of the potable water supply for domestic and industrial use and fire flow demand shall be identified in this submittal. If lawn irrigation is required, the source of water for the irrigation system shall also be identified in this submittal. Domestic water shall not be used for irrigation. Provide calculations indicating available supply and pressure versus required supply and pressure. If a pump, water storage tank, or any other peripheral equipment is required, provide calculations to support the selected pump size, storage tank volume, and sizes of peripheral equipment. Individuals experienced in fire protection systems must accomplish design of the fire pumping stations. The designer shall determine in this submittal whether a fire pump station with or without a ground storage reservoir is required.

7.3.1.2 Service Lines

Service lines are the water lines connecting building piping to water distribution lines. The analysis for service lines shall show service line size, domestic demand, velocity, and pressure drop between the water distribution line and building.

7.3.1.3 Water Distribution Lines

The water distribution system comprises the network of piping throughout building areas and other areas of water use or fire demand, and includes hydrants, valves, and other appurtenances used to supply water for domestic, industrial, and firefighting purposes. If new water distribution lines are required to meet fire flow demands, A Hardy Cross or similar analysis shall be provided in the Design Analysis. This shall consist of a flow analysis based on fire flow test results from the nearest fire hydrants to the points of connection to the existing distribution system, and fire flow demands developed from criteria contained in UFC 3-600-01. The flow through all lines shall be balanced by use of a Stet Cross analysis or other approved means. If the existing system is proven to be inadequate to supply the fire demand, revision to the existing distribution system may be required. This will be documented even though it may not be part of the project.

7.3.1.4 Sanitary Sewers

New gravity sanitary sewers shall be sized in this submittal. The design analysis shall show wastewater flows, velocities, pipe sizes, elevations, and pipe capacities. Where new sewage collection systems are to be connected to the existing system, the existing sewage collection system shall be checked to determine whether it has adequate capacity for the additional flow. If the existing system does not have sufficient capacity, it shall be revised to handle the increased flow. The design analysis shall contain a narrative description with all necessary calculations for new wastewater lift stations and force mains showing flows, velocities, component capacities, head requirements, detention periods, etc. A design analysis is required for onsite sewage treatment and disposal systems (e.g. septic tank and tile field). The feasibility of an onsite sewage treatment and disposal system where buildings are remotely located, and it is not economically possible to connect to an existing wastewater collection system shall be determined. Coordination shall be made with the appropriate county sanitarian to determine soil percolation rates to use for sizing the tile fields. Permits for septic tank and tile fields are not generally required for Federal projects, but the criteria established by the local authorities is typically employed unless an appropriate justification can be cited.

7.3.1.5 Building Connections

Building connections are the sanitary sewers connecting the building plumbing system to the wastewater collection system. A design analysis of gravity building connections is not required if the same slope for the building plumbing can be maintained to the street line. If that slope cannot be maintained, an analysis shall be provided to determine pipe slope. The minimum pipe diameter shall not be less than 6 inches. All plumbing connections will end five feet from a new construction.

7.3.1.6 Lift Station

If a lift station and force main are required to transport the wastewater from the building, a design analysis is required to show rationale for pump selection and size of force main. No grinder pumps are allowed on Eglin. Only vortex pumps shall be used.

7.3.1.7 Domestic and Industrial Wastewater Treatment

Calculate the average and peak loadings for individual unit processes including hydraulic, organic, solids, etc. Provide detailed descriptions of proposed unit processes including type, size, capacity, supporting data, and calculations showing the degree of treatment expected in each unit process, as well as the overall treatment efficiency. Provide narrative discussion of controls, instrumentation, and proposed operating sequences or methods. Include discussion of features for operator safety and comfort. Provide narrative indicating that the treatment facility was designed to simplify operation and minimize maintenance. Provide calculations to support selected equipment and pipe sizes. Provide pollution control authority design requirements.

7.3.2 Drawings

The water and sanitary site plan shall be adequately detailed to show new work and connections to the existing water distribution system and wastewater collection system. The proposed designs shall include sufficient details to obtain adequate concept cost estimates for all items such as lift stations, septic tanks, oil separators, etc. The invert elevations of all new and existing sanitary sewer lines and the top and invert elevations of all new and existing manholes shall be shown on the plans. The designer shall provide any additional drawings other than those listed above which he considers necessary to show the intent of the design.

7.3.3 Environmental Permitting

A separate section shall be provided in the Design Analysis entitle “Environmental Permits”. A separate sheet for each environmental permit contact shall be provided in the design narrative. The sheet shall contain the following information: Subject; Type Permit Required; Approving Agency and Address; Point of Contact and Telephone Number; Fee; Agency Processing Requirements; and any Special Requirements or Information.

7.4 INTERIM DESIGN (50-65%)

7.4.1 Design Analysis

The Interim Design Analysis shall include all items in the Concept Design Analysis and any necessary updates or revisions. Provide catalogue cuts, pump curves, and any other manufacturer’s information on selected equipment.

7.4.2 Drawings

The following specific items shall be submitted when applicable.

7.4.2.1 Water Supply

Provide detailed floor plans and sections of pumping stations with equipment layout, piping, and sufficient dimensions and elevations to physically locate all items of equipment, piping, etc. Provide hydraulic profiles of sanitary sewers and storm water.

7.4.2.2 Domestic and Industrial Water and Wastewater Treatment

Provide detailed floor plans and sections of treatment plants and pumping stations with equipment layout, piping, and sufficient dimensions and elevations to physically locate all items of equipment, piping, etc. Provide instrumentation and control schematics.

7.4.2.3 Water Distribution and Wastewater Collection Systems

Provide a site plan showing all existing and new valves, fire hydrants, manholes, pumping stations, laterals, meters, etc. Include sizes of all water lines, sanitary sewers, and force mains. Invert and rim elevations are required for all manholes. Provide profiles of gravity sewers. Double lines are required for profile piping. Provide details for connecting new lines to existing systems.

7.4.3 Specifications

Provide redlined marked-up specifications in accordance with Chapter 2, SPECIFICATIONS.

7.5 FINAL DESIGN (UNREVIEWED 100%)

7.5.1 Design Analysis

The Final Design Analysis shall be a refinement of the Interim Design Analysis. Design analysis shall include all references for design assumptions. Design analysis shall incorporate all accepted comments from the previous design submittal. All pipe-sizing computations shall be included in analysis. Piping analysis shall show design flows, pipe sizes, friction factors, slopes, lengths, elevations where applicable, conducted quantity, and velocity in each line. Provide flow diagrams in the analysis. Determination of pump heads shall be based on complete takeoff of friction losses and static heads. Systems head curves are required for all pump systems. Pumping stations with multiple pumps shall be provided with pumping curves for the individual pumps and any combination of possible pump operation that will occur.

7.5.2 Drawings

Final plans shall be the refinement and completion of the interim drawings. All comments relating to interim or concept design shall be incorporated in the final drawings. Where crowded conditions exist due to close proximity of other phases of the work, sufficient sections and elevations shall be shown to clearly indicate the exact location of new facilities. The number of elevations and details shall be sufficient to allow construction and installation of work without additional design work by the contractor. Where equipment connection details are shown, indicate all required valves, trim, gauges, and fittings required. Coordinate with the specification requirements and make sure that valves, fittings, etc. that are specified to be furnished with each piece of equipment are included in the detail. Final plan shall show all pipe sizes. Catwalks, ladders, platforms, access panels, and doors required for operation and maintenance of equipment, valves, and accessories shall be detailed on the drawings. Performance characteristics for all items of equipment shall be placed in carefully prepared equipment schedules. Equipment characteristics specified in "note" fashion, or in random locations on the drawings are not acceptable. Equipment characteristics selected shall not be restrictive to any one manufacturer but must be competitive among at least three major manufacturers. Manufacturer's trade names shall not be shown on the drawings. Electrical characteristics, horsepower ratings, classification of National Electrical Manufacturers Association (NEMA) type, if applicable, and except in special cases, rotation speeds shall not be included in equipment schedules. Location of equipment and piping shall be completely coordinated with other features of the project; architectural, plumbing, mechanical, structural, electrical, etc. Profiles shall be provided for all new sanitary sewers and force mains. These profiles shall indicate elevations, depth of bury, and interfering utilities which may be encountered. Profiles for building connections may not be required depending on length of run,

topography and state permitting requirements. Complete construction details of water and sanitary sewer utilities as well as layouts shall be required on final plans. A legend shall be provided on drawings to clearly differentiate between existing and new construction. Existing construction is generally indicated by light symbols, and new construction is indicated by heavy black symbols. Existing construction data such as pipe sizes, elevations, valves, and fire hydrant locations, etc. pertinent to new construction shall be included on the drawings.

7.5.3 Specifications

Provide redlined marked-up specifications if not provided at the Interim submittal. Provide final edited specifications if an Interim submittal was prepared in accordance with Chapter 2, SPECIFICATIONS. Guide specifications shall be included in this submittal. Specifications shall not be restrictive. Generally, the description shall be such that at least three major manufacturers can meet the specified requirements. Do not use trade names in the specifications unless a sole source authorization has been approved. The subparagraphs on “Electrical Work” shall be fully coordinated with the electrical section of the specifications. There shall be no conflicts as to which section covers starters, controls, or wiring; and no conflicts as to the type of starters required for the individual items of equipment.

7.5.4 Environmental Protection

- (a) The appropriate UFGS Guide Specifications section for “Environmental Protection”, shall be included in this submittal. A list of all required construction permits, existing environmental permits, and new environmental permits shall be included in this specification section.
- (b) All permits obtained by the user or required to be obtained by the user or designer shall be listed by title, permit number or form number, permitting agency, effective date, and expiration date. The list shall include but is not limited to the following:
 - Federal Aviation Administration Construction
 - Storm water Discharges
 - From Construction Activities Permit
 - Stormwater Management System
 - Environmental Resource Permit
 - State Wetlands Dredge and Fill Permit
 - Construction Permit for Water Line Extensions
 - Construction Permit for Sanitary Sewer Work
 - Air Pollution Construction Permit
 - Consumptive use Permit for Water (Florida – water wells)
- (c) A separate list in the same format as above will also be prepared for all permits to be obtained by the contractor. Permits to be obtained by the contractor include but are not limited to the Well Drilling Permit.

7.6 READY-TO-ADVERTISE (REVIEWED 100%)

All final design drawings, specifications, and the design analysis and cost estimate will have incorporated comments from the preceding reviews before submittal as Ready-To-Advertise.

Chapter 8 - Architecture

8.1 GENERAL

8.1.1 Scope

This chapter states criteria, requirements, and guidance for architecture design. Specific guidance for facilities located on Eglin AFB are provided in the most current version of the Eglin Architectural Compatibility Plan (ACP). All work relative to U.S. Army 7SFG(A) facilities shall be completed in accordance with the most current version of the 7SFG(A) Architectural Compatibility Plan (ACP). **Any information provided in this chapter that conflicts with those provided in the ACP shall follow the requirements of the appropriate ACP.**

8.1.2 Architectural Quality

The objective of Eglin Air Force Base is to obtain attractive, cost-effective buildings which are designed using sound technical knowledge and which are constructed using recognized commercial building industry practices. The design shall incorporate those characteristics which will provide buildings with present and continuing utility, durability, and desirability, provide a safe and healthy environment, meet sustainability goals, and which will be economical to maintain for the life of the building.

8.2 APPLICABLE PUBLICATIONS

8.2.1 Building Code Compliance

The following publications shall be used to establish code compliance for architectural work. Additional discipline or user provided publications shall be incorporated when they affect life safety and occupational safety and health.

UFC 1-200-01	Unified Facilities Criteria (UFC) 1-200-01, General Building Requirements
IBC	International Code Council, International Building Code (IBC)
NFPA 101	National Fire Protection Association (NFPA), Life Safety Code, NFPA 101
ABA	Architectural Barriers Act
ADA	Americans with Disabilities Act
UFAS	Uniform Federal Accessibility Standards (UFAS)

8.2.2 Functional Criteria

Eglin Air Force Base Architectural Compatibility Plan shall be used as a guide for specific criteria as it applies to all facilities on Eglin AFB. The 7 SFG(A) Architectural Compatibility Plan shall be used for facilities within the 7 SFG(A) Cantonment Area and all facilities provided exclusively for 7 SFG(A) personnel use.

8.3 PROJECT DEFINITION SUBMITTAL (10% - 15%)

During this phase the designer must define the customer's requirements and confirm that they can be met within the project's constraints. To that end, a comprehensive interface with the end users is required generally through a charrette or other previously approved data gathering process. The primary purpose of the design process at this stage is to gather any information from the customer that would be necessary in the design of the facility.

8.3.1 Narrative

8.3.1.1 General Description of the Project

State the purpose, function, and space requirements in sufficient detail to delineate and characterize functional features and the desired image or visual appearance of the project. The narrative shall reflect the regional architecture as well as the visual characteristics of the existing facilities around the site.

8.3.1.2 Basis of Design Summary

Provide a summary of the Basis of Design including, but not limited to the following:

- (a) State the building construction type and occupancy classification appropriate to the model code(s) in use.
- (b) List the functional areas and describe their relationships.
- (c) List authorized space allocations.
- (d) Describe the energy conservation measures used in the design.
- (e) Describe the noise control criteria established for the design.
- (f) Describe methods to ensure safety and accessibility compliance with the latest requirements of OSHA, ADA-ABA, ADAAG, and UFAS.
- (g) State any requirements for exterior finish materials and color selection. Indicate that consultation has occurred with the Eglin Engineering Offices, and that the finish materials and colors selected for the project are in accordance with the Eglin Architectural Compatibility Plan or 7SFG(A) Architectural Compatibility Plan as applicable.
- (h) Describe any special functional or technical requirements including, but not limited to, physical or classified document security, anti-terrorism and force protection, and sustainable design.

8.3.1.3 Criteria

List the functional and technical criteria used to guide the design work.

8.3.1.4 Building Organization Analysis

Submit, as necessary, any graphic design aids such as affinity drawings, spatial organization and relationship matrices, and space layout sketches in a sequential order, with sufficient narrative to indicate the reasoning and justification for major design decisions. Any provisions for future expansion shall be indicated, including schedules for phasing.

8.3.1.5 General Design Statement

The designer shall state the assumptions and rationale behind all major facility design decisions including, but not limited to, discussions of the following:

- (a) Orientation to the sun, wind, and water (when applicable).

- (b) The relationship to any surrounding natural or man-made environment.
- (c) The interface with any contiguous traffic circulation.
- (d) The visual impact of the facility regarding the overall area.

8.3.1.6 Design Calculations

Submit complete calculations for the following:

- (a) Gross building area.
- (b) “U” values for each exterior construction assembly (walls and roofs)
- (c) Calculations for toilet fixture count.
- (d) Roof Drainage (roof drain sizes and quantities, gutters and downspout sizes) based on rainfall intensity at the project location.
- (e) Gross area tabulations.

8.3.2 Drawings

This submittal consists of one or more single line schematic floor plans which effectively indicate to the using agency that the function, circulation, and life safety issues have been assessed and can be met by the proposed design. At least one major elevation (preferably the front elevation) for each submitted building is required. A site plan is required to indicate the building orientation and circulation to the building entrances. The site plan shall be coordinated with the requirements of Chapter 3, titled SITE DEVELOPMENT.

8.4 CONCEPT DESIGN SUBMITTAL (30% - 35%)

8.4.1 General Considerations

The minimum requirements for this submittal consist of floor plan(s) drawn to appropriate scale, a Life Safety Analysis Plan, exterior building elevations, typical wall sections to indicate material usage and structure, and a design analysis. Additional drawings may be required at this submittal due to the complexity of the project (i.e. hospitals, research facilities, blast resistant structures, etc.) to adequately describe the proposed design.

8.4.2 Design Analysis

Update and continue development of the narrative submitted at Project Definition.

8.4.3 Drawings

8.4.3.1 Composite Floor Plans

When the main floor plans must be drawn in segments to comply with the requirements for scale and sheet size, provide a composite floor plan for each floor level. These plans shall show the following:

- (a) The general building layout showing exterior walls, interior partitions, and circulation elements (stairs, elevators, corridors, etc.) drawn to scale.

- (b) The identification of major areas and their functional relationship.
- (c) Overall building dimensions, out to out.
- (d) Planning grid or column lines where applicable.
- (e) Match line locations indicating larger scale floor plan segments.
- (f) Cross-references for enlarged floor plans and building sections.

8.4.3.2 Floor Plans

Provide a floor plan or floor plan segments, 1/8-inch scale minimum, 1/4-inch preferred (and mandatory for Health Care facilities), for each floor showing functional elements, drawn to scale. In addition, the following shall be shown:

- (a) Planning grid and/or column lines.
- (b) Overall and building element location dimensions.
- (c) Room names and numbers.
- (d) Finish floor elevations for each floor or change in floor level.
- (e) Opening designations in walls (doors, windows, etc.).
- (f) All major equipment.
- (g) Furnishings layouts for typical rooms where required.
- (h) Gross floor area tabulations if not shown in composite floor plans.
- (i) Cross-references for sections and details.
- (j) Provisions for the handicapped where required.
- (k) True North Arrow, Plan North Arrow
- (l) Wall construction, Firewall, Door & Window callouts
- (m) Limits of Flooring Types

8.4.3.3 Roof Plan

Provide a roof plan showing the following:

- (a) Planning grid and/or column lines
- (b) Overall and building element location dimensions.
- (c) Indication of roof slope and drainage.

- (d) Roof accessories (skylights, roof scuttles, etc.)
- (e) Major roof-mounted equipment.
- (f) Gutters and downspouts.
- (g) Roof details cross-references.

8.4.3.4 Demolition Plans

Floor plans showing demolition work in sufficient detail to indicate all existing building materials and finish conditions are required for renovation and modification projects. Drawings shall be of sufficient detail to indicate “existing to remain”, “remove existing”, and new work materials. Contractors are not required to site verify correctness or completeness of renovation and modification contract drawings and specifications during bid preparation, therefore, the drawings shall be complete with adequate detail and descriptions of existing materials, assemblies, and systems (type, thickness, quantity spacing, length, width, height, etc.) to enable the contractor to bid on the project.

8.4.3.5 Building Elevations

Provide building elevations showing the exterior design of all major elevations. Each elevation shall show the following:

- (a) Planning grid and/or column lines
- (b) Building masses.
- (c) Door and window opening designations, and penetrations by other disciplines.
- (d) Identification of major building materials.
- (e) Roof-mounted equipment and roof accessories when visible in elevations.
- (f) Elevations and vertical dimension of floor lines.

8.4.3.6 Building Sections

Provide building sections as necessary to demonstrate the coordination of the structural, mechanical, and electrical systems. In addition, the following shall be shown:

- (a) Planning grid and/or column lines.
- (b) Structural system.
- (c) Changes in floor levels.
- (d) Finish ceilings.
- (e) Floor-to-ceiling and floor-to-floor heights.
- (f) Floor elevations.

- (g) Spaces to be used by the lighting and HVAC systems.
- (h) Adjacent grades.
- (i) Sections and details shall show material callouts

8.4.3.7 Typical Wall Sections

Provide typical wall sections (3/4-inch scale preferred). All sections shall be fully noted. These sections shall show the following:

- (a) Structural system.
- (b) Exterior wall and roof assemblies.
- (c) Ceiling systems.
- (d) Floor-to-ceiling and floor-to-floor heights.
- (e) Floor elevations.
- (f) Spaces to be used by the lighting and HVAC systems.
- (g) “U” values through roof, walls and floors.

8.4.3.8 Details

In addition to the above requirements, show details of any significant design features and any sections necessary to demonstrate the required coordination of the various building systems.

8.4.3.9 Life Safety Analysis Plan

Life Safety Analysis Plan sheets shall be referenced as architectural sheets and placed after the other Architectural Drawing sheets in the contract drawing submittal set. Include the following data and provide a legend for symbols used on the drawings:

- (a) Type of occupancy.
- (b) Type of construction.
- (c) Fire/smoke compartments.
- (d) Exit width calculations and number of exits.
- (e) Location and rating of walls (1 hr, 2 hr, etc.).
- (f) Door and Window labels.
- (g) Door hold open devices.
- (h) Fire extinguisher and/or fire hose cabinet locations.

- (i) Egress, dead-end, and common path of travel distances indicating code compliance.
- (j) Smoke proof doors.
- (k) Exit lights.
- (l) Wall types.

8.4.4 Specifications

Provide outline specification in accordance with Chapter 2, SPECIFICATIONS.

8.5 INTERIM DESIGN SUBMITTAL (50% - 65%)

8.5.1 Design Analysis

The Design Analysis shall include all items in the Concept Design Analysis narrative and any revisions made necessary by comments about the Concept Design submittal. In addition, verify site and building signage requirements.

8.5.2 Drawings

Incorporate comments from the Concept Design review.

8.5.2.1 Building Plans

- (a) Provide plans for each floor, roof, and ceiling showing dimensions, functional arrangement, and equipment for all areas, including corridors, exits, stairs, and utility spaces.
- (b) The relationship of the building to exterior areas, vehicle parking, service areas, etc., shall be indicated on the site plans.
- (c) Individual treatment shall be given to special design or items involving deviation from normally accepted standards.
- (d) All column lines shall be designated to aid in locating project components.
- (e) Identify fire walls, smoke partitions, and all fire rated construction.
- (f) Show indications of phased construction if required.
- (g) Thoroughly cross-reference section cut symbols and plans and elevations to detail sheets.
- (h) Complete door and window details to minimum 65%.
- (i) Identify all interior wall and partition types on floor plans and reference them to detail sheets showing construction, heights, fire ratings, and acoustical ratings.

8.5.2.2 Schedules

The drawings shall include door, window, and equipment schedules. Schedules need not be complete at this point; however, they shall be sufficient to indicate the door and window sizes and major equipment items.

8.5.3 Specifications

Provide redlines marked-up specifications in accordance with Chapter 2, SPECIFICATIONS.

8.6 FINAL DESIGN SUBMITTAL (UNREVIEWED 100%)

8.6.1 Design Analysis

The Final Design Analysis narrative shall include all items in the Interim Design analysis narrative and any revisions made necessary by comments about the Interim Design submittal.

8.6.2 Drawings

- (a) Complete to the extent required for the Ready-To-Advertise Submittal. Drawings are to be complete, except for incorporation of comments about this submittal.
- (b) Incorporate Interim Design review comments into the drawings.
- (c) Ensure that all details, sections, etc., necessary for the final documents have been added to the drawings and are complete and thoroughly cross-referenced.
- (d) Complete all schedules. Ensure that hardware sets have been added to the door schedule and coordinated with the specifications.

8.6.3 Specifications

Provide redlines marked-up specifications if not provided at the Interim Submittal. Provide final edited specifications if an Interim submittal was prepared in accordance with Chapter 2, SPECIFICATIONS.

8.7 READY TO ADVERTISE SUBMITTAL (REVIEWED 100%)

8.7.1 Design Analysis

Complete analysis supporting the requirements of the project.

8.7.2 Drawings and Specification

Complete thoroughly checked drawings and specifications, with all comments from the final review incorporated.

8.8 TECHNICAL REQUIREMENTS

Materials and construction methods shall comply with the instructional notes inserted in the applicable UFGS.

8.8.1 Coordination

All architectural work shall be coordinated with work of other technical disciplines.

- (a) Ensure adequate above-ceiling space for ductwork, piping, lighting, structural members, etc.
- (b) Coordinate reflected ceiling plans with lighting and HVAC plans.
- (c) Coordinate light switches with door swings.
- (d) Coordinate electrical and mechanical drawings with architectural plans to assure proper power, gas, water, etc. for drinking fountains, kitchen equipment, etc.
- (e) Coordinate with other disciplines to ensure there are no conflicts in roof drain, exhaust fan, louvers, and other similar item locations.
- (f) Ensure all louvers are coordinated with mechanical drawings and that no louvers are in fire or smoke doors.
- (g) Coordinate structural with architectural to ensure framing at all roof openings.
- (h) Coordinate electrical and instrumentation to ensure utilities are provided for power operated doors and doors requiring electrical or electronic controls.
- (i) Ensure all rated wall penetrations receive fire stopping or receive fire rated sealant around penetrations.

8.8.2 Site Work

8.8.2.1 Floor Relation to Grade

The finished floor of concrete floor slabs on fill shall be a minimum of 6 inches above the finished grade.

8.8.2.2 Access to Entrances

All stoops, steps, or similar required access to entrances that will normally be built by a building contractor as differentiated from sidewalks, driveways, etc. which are normally constructed by a paving contractor, shall be shown and detailed on the architectural drawings. Ramps complying with the requirements of ADAAG and UFAS shall be provided where required to allow access by the physically impaired.

8.8.3 Masonry

- (a) Coordinate with project Structural Engineer for incorporation of standard and non-standard CMU details including bond beams and vertical fill cells.
- (b) Coordinate with project Structural Engineer for incorporation of an efflorescence-controlling admixture for mortar.

8.8.3.1 Interior Walls and Partitions

Concrete masonry units (CMU) for interior masonry walls and partitions shall not be less than 6 inches in normal thickness.

8.8.3.2 Split Face and Fluted CMU

Where split face or fluted units are used, provide smooth face units where concrete paving or flashing occurs, and where items are attached to, or penetrate CMU wall surface.

8.8.3.3 Coursing

Concrete masonry unit coursing generally shall be coordinated with door and window heights and widths to minimize the need for cutting block.

8.8.4 Miscellaneous Metals

All access panels required to service mechanical items normally furnished and installed by the non-mechanical trades shall be shown on the architectural drawings. Ensure that access panels, when required, are specified and detailed.

8.8.5 Thermal and Moisture Protection

8.8.5.1 Insulation

General standards for insulation, as indicated in the applicable UFGS, require insulation thickness as determined by the established “U” value for total roof or wall thickness, and the type insulating material utilized. “U” values shall be indicated as coordinated with the project Mechanical Engineer.

8.8.5.2 Vapor Barrier

The exterior envelope of all cooled facilities shall have a continuous, positive vapor barrier of at least 0.06 permeance as coordinated with the project Mechanical Engineer.

8.8.5.3 Moisture Barrier

- (a) Verify and incorporate appropriate moisture barriers in exterior veneer wall systems.
- (b) Standing seam metal roofs installed over a structural metal deck and rigid insulation shall include a 40 mil, self-sealing, secondary water barrier.

8.8.6 Roof Systems

- (a) When roof top equipment is installed that will require maintenance, ensure that roof hatches are provided for multi-story buildings and access ladders, or roof hatches are provided for single story buildings. Hatches and ladders shall be secured to prevent unauthorized access.
- (b) The minimum roof slope for built-up roofs shall be ¼-inch per foot, however, the use of a “flat” built-up roof is discouraged except for facilities on unusual building configuration or extremely large areas. In no case shall a built-up roof slope exceed 2 inches per foot. Roof slope for standing seam metal roofs shall be 1 in 12 minimum. Refer to Eglin Architectural Compatibility Plan for additional information.

8.8.6.1 Standing seam Metal Roofs

- (a) Roof panels shall be a minimum thickness of 24-gauge steel or 0.040 aluminum.
- (b) Follow manufacturer guidelines in design and installation to permit

expansion/contraction of the roof system.

- (c) Vented ridge caps are not desirable due to potential leaks.
- (d) Concealed mechanically formed seams are preferred. Install with fasteners permitting expansion/contraction attached to the structural deck (when present) through rigid insulation (when present) or locking type seams (as opposed to snaplock type).
- (e) An independent roofing consultant shall be hired by the roofing subcontractor for roofs over 10,000 square feet. The consultant shall review and approve roofing shop drawings prior to submittal to the government. The consultant shall be present to monitor and certify the entire roof installation. The consultant shall be certified by the roofing manufacturer.
- (f) Ensure that pressure treated wood blocking (if incorporated) is designed and shown in the drawings at roof edges.
- (g) Roof penetration flashing, curbs, gutters, and flashing shall be the product of the roofing manufacturer.
- (h) All laps shall be in the direction of water flow.
- (i) Full length, job fabricated panels are recommended. Individual roof panels less than 50 feet in length with joints are not permitted.
- (j) Ensure that roof penetrations occur in the center of individual roof panels rather than at the edges.
- (k) Roof edge gutters shall be installed with gutter hangers and shall not be attached directly to the roof membrane or fascia. The front edge of the gutter shall be below the back edge at least 1 inch below the roof edge.
- (l) If fascia and/or soffit panels are to match the roof system color, ensure that different manufacturers provide matching colors. Roof panels are not acceptable as fascia.
- (m) Where rigid insulation is installed, ensure that its compressive strength is compatible with the standing seam metal roof system as recommended by the manufacturer.
- (n) Roof colors must match those provided in the Eglin ACP or 7 SFG(A) ACP as applicable.
- (o) IAW UFC 3-110-03 (1-8.5) incorporate fall protection control measures in the design of roofs for inspection and maintenance of roof, equipment, etc. Design must include certified and labeled anchorages IAW OSHA 29 CFR 1910.28 and American National Standards Institute (ANSI) Fall Protection Series Z359 Codes 1-14. Plan shall provide a detail of fall protection anchor points for roof and equipment maintenance and inspections. Roof Plan View shall indicate location of anchor points. Fall protection system design and engineering shall be coordinated with the building systems in which it is attached to assure sufficient strength is provided for the fall protection system operation and use. Roof warranty placards shall be mounted adjacent to roof access ladders, hatches, etc. as applicable.

8.8.6.2 Other Roofs

For other roof types, comply with the National Roofing Contractors Association standards.

8.8.6.3 Sheet Metal

In all cases, sheet metal for various elements used throughout a building shall be of the same basic metal. Atmospheric conditions shall be considered in the selection of exposed sheet metal. Different types of sheet metal that can cause accelerated corrosion (galvanic action) of wither one shall not be placed in direct contact. Sheet metal used on roofs with concrete roof tiles shall not react with nor corrode excessively due to the concrete.

8.8.6.4 Gutters and Downspouts

When downspouts are required, they shall not drain directly onto a walk or platform. When downspouts must occur at walks or platforms, they shall pass through, or under, into underground drains or toward open ground beyond. Downspouts draining onto open ground shall be diverted using precast concrete splash blocks to prevent erosion. Use of interior downspouts shall be avoided wherever design permits. The use of scupper should be maximized. Avoid built-in gutters behind fascia or parapet due to expansion/contraction of metal and surrounding material unless dictated by Eglin requirements. All gutters shall have leaf screens at locations susceptible to collection of leaves and other blown debris.

8.8.7 Doors

Door schedules shall be indicated on the drawings.

8.8.7.1 Pedestrian Doors

All pedestrian doors shall be a minimum of 7 feet 0 inches or 7 feet 2 inches high. Door openings, in general, shall be 3 feet 0 inches wide, except for special purpose doors, toilet rooms (except for handicap).

8.8.7.2 Doors to Rooms

Doors to rooms shall be of adequate size to accommodate the installation and removal of furniture and equipment installed therein.

8.8.7.3 Exterior Doors

- (a) Except in underground structures and floors above the first story of multi-story structures, doors to boiler or mechanical rooms, doors from power rooms, generator rooms, and doors from similar areas should be to the outside of the building only. Electrical closet and air handling room doors may open to the building interior.
- (b) Where galvanized steel doors and frames are required, ensure use of A40 or A60 designation is used in lieu of G type coatings.
- (c) All surfaces of wood doors shall be sealed

8.8.7.4 Special-Purpose Doors

Special-purpose doors, such as rolling and coiling doors shall be adequately designed to safely resist the

design wind pressure. Rolling and coiling steel or aluminum doors shall be designed as to permit operation of the doors as maximum wind velocities defined in the area where used.

- (a) High security door hardware shall comply with FFL 2890B-A3 Jan 25, 2017. These locks shall be included in the project as Government Furnished Contractor Installed (GFCI) equipment.
- (b) High security door hardware shall be installed by personnel processing the manufacturer’s certification.

8.8.7.5 Finish Hardware

- (a) Carefully read the “Notes to Specifier” for the UFGS hardware specification. Hardware shall be selected from BMHA and ANSI standards. All cylinders shall have 7 pin small format interchangeable core. Provision of these items must conform to the individual requirements of Eglin Air Force base.
- (b) Floor mounted center door stops for door pairs shall not be installed above floor level.

8.8.7.6 Hardware Set Designations

Hardware set designations shall be listed in the Door Schedule in preference to locating on the floor plans. Specification Section 08 71 00, Door Hardware, shall provide the necessary hardware set designation numbers, plus description and function of each hardware item included in the hardware set.

- (a) The manufacturers list below is only intended to show products like the standard set. All manufacturers below are subject to compliance with the requirements of the project specifications and relative contract documents. Approval of any manufacturers listed below shall be in accordance with their meeting the requirements of the specifications:

<u>Item</u>	<u>Manufacturer</u>
Hinges	McKinney, Ives, Bommer
Continuous Hinges	Stanley, Roton, Select
Mortise Locksets – Premium	Best 45H, Schlage L9000, Sargent 8200
Cylindrical Locksets – Premium	Best 9K, Schlage DL, Sargent 11 line
Auxiliary Locks	KABA-Mas Type VI, Lockmasters, LKM10K Type II, IV, VII, X, Sargent & Greenleaf 2890 Type II, IV, VII, X (Those devices specified under FFL 2890C with Style 1 lock devices)
Electronic Strikes	HES1006, HES1500, Securitron UNL/MUNL
Cylinders / Cores	Best 7-pin PATD Cormax (Owners Standard)
Key Switches	Best-1W Series or equal pre-approved
Exit Devices – Premium	Precision Apex, Von Duprin 98, Sargent 19-88
Pulls	Trimco, Rockwood, Ives
Closers – Heavy Duty	Stanley QDC100, LCN 4041, Sargent 350
Stops	Trimco, Rockwood, Ives

Overhead Stops
Flat Goods
Thresholds & Gasketing
Electro Mag Hold Opens

ABH, Rixon, Glynn Johnson
Trimco, Rockwood, Ives
National Guard, Pemco, Zero, Reese
ABH, SDC, LCN, Securitron

- (b) Electrified Door Hardware; Unless otherwise specified, engineer door openings/hardware for use with Electronic Access System as follows: Non-electrified lockset paired with an electronic strike. Exception FFL 2890C Type II, IV or VII devices.
- (c) Ensure electronic door hardware is properly addressed in glass storefront doors. Conduit shall be hidden within the frame.

8.8.7.7 Return Air

Overall size of return air louvers located in doors shall be included in the door schedule. Minimum bottom rail dimension shall be 5 inches. Door undercuts shall be shown in the Door Schedule.

8.8.8 Windows

- (a) Window schedules and types shall be indicated in the drawings.
- (b) Ensure that window types and locations are coordinated with furniture placement to avoid blocking views.

8.8.9 Finishes

8.8.9.1 Acoustical Plaster and Acoustical Tile

The use of acoustical plaster is discouraged. In electronics and communications facilities in which avoidance of dust is a major consideration, acoustical treatment shall be limited to acoustical tile or gypsum wallboard with non-dusting characteristics.

8.8.9.2 Ceramic Tile

- (a) Caulk joint between ceramic tile and bathroom fixtures (showers, tubs, etc) in lieu of filling with grout.
- (b) Ensure that ceramic tile installation is coordinated with toilet accessories and light switches in restrooms.
- (c) Coordinate colors and patterns of wall tile with ceramic tile base
- (d) Coordinate tile placement around floor drains

8.8.9.3 Gypsum Wall Board

Ensure that control joints are in the drawings and installed at appropriate heights to protect wall finish. Wall board joints will be staggered. Expansion joints of GWB will be in runs of over 30 feet. Reentrant corners will be protected.

8.8.9.4 Chair Rails

In rooms with movable furniture, ensure that chair rails (when used) are installed at appropriate heights to protect wall finish.

8.8.9.5 Paint

Exterior grade paint shall be specified for interior spaces open to exterior humidity and temperature weather conditions.

8.8.10 Equipment

- (a) Verify that partition thicknesses are sufficient for installation of recessed or semi-recessed equipment including toilet accessories.
- (b) Ensure that partition thicknesses are sufficient for installation of concealed plumbing utilities.
- (c) Ensure that ceiling recesses are provided at overhead coiling doors.

8.8.11 Rooms and Space for Utilities

Rooms and space for utilities, including mechanical and electrical equipment rooms, shafts, chases, and chimneys, shall be indicated on the Project Definition Design and subsequent submittal design drawings, even though their exact size may not be determined at that stage.

8.8.12 Floor Drains and Slopes

Floor drains and slopes, hose bibs, and shower heads shall be shown on the architectural drawings as well as on mechanical drawings and shall be closely coordinated. All floors in areas requiring drains shall be sloped towards the drains.

Chapter 9 - Structural

9.1 GENERAL

9.1.1 Scope

This chapter provides criteria, requirements, and guidance for the structural design of buildings and other structures.

9.2 PROJECT DEFINITION (10% - 15%)

At the Project Definition phase, the designer must define the specific project requirements and confirm that they can be met within the project constraints. This is normally done through a charrette or other data gathering process. The structural engineer shall also coordinate with the architect at this phase to ensure that the architectural floor plan and other architectural features of the project can be framed and constructed economically. The Project Definition submittal shall consist of a narrative describing the structural loads, general design criteria and references and any unusual design conditions. The narrative shall include a brief discussion of the intended structural system or, if the size of the project warrants, a description of the structural systems to be used for comparative analysis.

9.3 CONCEPT DESIGN (30% - 35%)

9.3.1 Structural System Selection Analysis

- (a) An economical structural system shall be selected to meet the requirements of the design. For projects with a construction value of \$10,000,000 or greater, a comparative analysis of two or more competitive structural systems shall be required unless indicated otherwise in the Statement of Work (SOW). A portion of each facility large enough to be representative of the entire structure shall be designed in enough detail to provide for an estimate that will be the basis of the structural systems selection. The portion of the structure selected for comparing alternate system cost shall include framing for at least one typical bay of the roof, floor, and foundation systems. Additional costs of non-structural systems attributable to a structural alternative shall be included in the comparative cost estimate for that alternative. Determination of these additional costs must be based upon a concept of the complete building configuration, including architectural, mechanical, electrical, and other systems; hence the main structural members must be sized to check for compatibility with ceiling, duct, lighting, and all other space demands. The method of providing the required degree of fire-resistance shall be determined for each alternative and the cost must be included. The submittal shall include the following items:
 - (1) A complete description, with sketches, of each structural system considered.
 - (2) Design calculations supporting the member sizes used for the cost estimate.
 - (3) A comparative cost for each system, clearly showing all costs and quantities used.
 - (4) An analysis of the study results with justification for the system selected.

- (b) For projects with a construction value of less than \$10M, provide a rational justification of the proposed structural system.

9.3.2 Design Analysis

The following specific structural information shall be provided in a brief consolidated format:

9.3.2.1 References

List all references used in the Concept Design including UFC, industry standards, and project specific criteria provided at the Charrette or pre-design meeting.

9.3.2.2 Design Loads

Design load values to be used in the design shall be identified, including roof and floor loads, wind loads, lateral earth pressure loads, seismic loads, etc., as applicable.

9.3.2.3 Lateral Stability

Describe the method of providing lateral stability for the proposed structural system to resist seismic, wind, and other lateral loads. Include sufficient calculations to verify the adequacy of the proposed lateral load resisting system.

9.3.2.4 Fire Resistance

Describe the fire resistance requirements of the structure and the proposed materials and system to be used.

9.3.2.5 Antiterrorism/Force Protection (AT/FP) & Progressive Collapse

AT/FP and Progressive Collapse provisions which affect the structural design of the project shall be identified and briefly described. Refer to Chapter 18 ANTITERRORISM/FORCE PROTECTION (AT/FP) for specific guidance related to AT/FP and Progressive Collapse.

9.3.2.6 Structural Calculations

Calculations for typical roof, floor, and foundation members as applicable for the structural system proposed.

9.3.3 Drawings

Sufficient framing plans are required for roof, floors, and foundations, as applicable, to indicate layout of principle members. Typical sections shall be furnished through roof, floors, and foundations indicating materials and type of construction proposed. Drawings shall contain a set of general notes indicating design live, wind, and seismic loading, references used in the structural design, and applicable material strengths.

9.4 INTERIM DESIGN (50% - 65%)

9.4.1 Design Analysis

The interim Design Analysis shall include all items presented in the Concept Design analysis and any revisions necessitated by review comments on the Concept Submittal. Calculations shall be included for all principal members, including the structural foundations. Structural design issues related to AT/FP and

progressive collapse shall be presented in the Design Analysis along with structural calculations related to these issues.

9.4.2 Specifications

Provide redlined marked-up specifications in accordance with Chapter 2, SPECIFICATIONS.

9.4.3 Drawings

Drawings for this submittal shall include roof and floor framing plans, as applicable. All principal members shall be shown on the plans. A foundation plan shall also be furnished showing main footings and grade beams where applicable. Where beam, column, and footing schedules are used, they should be filled in sufficiently to indicate principal member sizes. Typical bar bending diagrams shall be included if applicable. Typical sections shall be provided for principal roof, floor, and foundation conditions. Slab-on-grade crack control joint locations shall be indicated, and appropriate joint details shall be provided. Formed concrete slab construction joint locations shall be indicated on the plans and appropriate joint details shall be provided. Masonry wall control joint locations shall be shown on the structural and architectural plans. Wall joints shall be carefully coordinated between the structural and architectural plans. Masonry walls supported directly by thickened slabs shall ensure that the slab crack control joints are located directly below the wall crack control joints. Typical applicable masonry construction details shall be provided. Comments made on the Concept Submittal shall be incorporated into the drawings for this submittal. The General Notes shall be developed to reflect the interim level of design. Rebar splice lengths and clearances to concrete surfaces shall be per ACI 318.

9.5 FINAL DESIGN (UNREVIEWED 100%)

9.5.1 Design Analysis

The Final Design Analysis shall include all items in the concept and interim design analysis and any revisions necessitated by review comments on the Concept and Interim Design submittals. Complete calculations for all structural members shall be included. Any calculation changes required by comments on the Interim and Concept design submittals must be incorporated.

9.5.2 Specifications

Provide specifications if not provided at the Interim submittal. Provide final edited specifications if an Interim submittal was prepared in accordance with Chapter 2, SPECIFICATIONS.

9.5.3 Drawings

Complete final plans, sections, and details of all structural elements are required. All roof and floor openings, with details, shall be shown on the structural drawings. Structural drawings shall be carefully checked to ensure coordination with architectural, civil/site, mechanical, and electrical drawings. Drawings must contain a complete set of general notes indicating design live, wind, and seismic loading, and all references used in the structural design. All applicable material strengths shall also be provided.

9.6 READY – TO – ADVERTISE (REVIEWED 100%)

9.6.1 Design Analysis

A final complete set of structural calculations shall be furnished, incorporating all changes made during the process of design. Calculations will be checked and verified by an engineer other than the original designer.

9.6.2 Specifications

Specification sections shall incorporate all comments from previous submittals. All redlines shall be removed from the specifications sections and the specifications shall be checked for brackets (if using SpecsIntact), section references, and publication references.

9.6.3 Drawings

Drawings shall incorporate all comments from previous submittals. All drawings shall be verified, finalized, and checked for consistency with the specifications.

9.7 TECHNICAL REQUIREMENTS

9.7.1 General

- (a) Structural design shall be in accordance with the criteria requirements, and guidance provided in the latest version of the IBC and as modified by UFC 1-200- 01 and the following requirements. Local building codes shall not be used.
- (b) The designer's Structural Engineer is responsible for ensuring that all mechanical and electrical equipment and other auxiliary building features such as sprinkler piping, etc. are properly supported and that all architectural features are adequately framed and connected. The Structural Engineer is also responsible for the design of all lesser structures such as utility vaults, pits, retaining walls, etc., although they may be shown on other disciplines drawings.
- (c) When future expansion of buildings or facilities is planned, it is especially important that the provisions made for the expansion are carefully developed and shown on the drawings.
- (d) Building structural details shall be shown on the structural drawings and not intermixed with architectural plans and details.

9.7.2 Design Loads

Load assumptions shall be in accordance with IBC and UFC 1-200-01 with the following modifications.

9.7.2.1 Wind Load Criteria

The design requirements of ASCE 7-05 shall be used.

9.7.2.2 Seismic Load Criteria

- (a) Bridges. Seismic criteria used for bridges shall be as set forth in the AASHTO HB- 17 Standard Specifications.
- (b) All other structures. Seismic criteria used for structures other than family housing and bridges shall be in accordance with IBC as modified by UFC 1-200-01.

9.7.3 Foundations

A minimum safety factor of 1.5 shall be provided against uplift, sliding, overturning, or floatation. All below grade column base plates and anchor bolts shall be completely encased in concrete or coated with coal tar epoxy.

9.7.4 Structural Steel

Steel structures shall be designed in accordance with IBC. Shop connections for structural steel shall be welded, and field connections will generally be made with high-strength bolts, ASTM A325 bearing-type connections. Connection angles shall be a minimum 5/16 inch thick, and bolts shall be a minimum 3/4 inch diameter. All connections other than standard AISC beam connections shall be designed by the structural engineer and detailed on the final plans. When standard AISC beam connections are used, beam end reactions shall be provided on the drawings. Design responsibility for all connections remains with the designer's Engineer of Record. Unless the structure involves very minor structural steel fabrication, the structural steel specification shall be edited to include the requirements that the steel fabricator shall be certified by the AISC Quality Certification Program for the appropriate category. For steel framed floor systems, design calculation shall be submitted demonstrating that the floor system is acceptable in accordance with the "AISC Steel Design Guide Series #11: Floor Vibrations Due to Human Activity".

9.7.5 Steel Joists

Steel joist construction shall be in accordance with the UFC. Joists will be anchored to steel supports by bolting or field welding. Steel insert plates shall be provided in concrete work as required. Maximum joist spacing will be 2.5 feet for floors and, generally, 5.0 feet for roofs. Where top chords are extended, the required section modulus of extensions shall be shown in the drawings. Where equipment is hung from joists, details of joist reinforcement at hangar locations shall be provided on the drawings. Floors shall be designed to prevent excessive vibration. For joist supported floor systems, design calculations shall be submitted demonstrating that the floor system is acceptable in accordance with the "AISC Steel Design Guide Series #11: Floor Vibrations Due to Human Activity".

9.7.6 Pre-Engineered Metal Buildings

Pre-engineered metal buildings shall be designed in accordance with the current standards of the Metal Building Manufacturer's Association (MBNA), except seismic loads shall be in accordance with the UFC and all other loads shall be in accordance with ASCE 7-05, except as noted. The metal building system shall be provided by a single manufacturer and shall include all components and assemblies that form the building including the standing seam metal roof system. The metal building system shall be required to be the product of a recognized steel building system manufacturer who has been chiefly engaged in the practice of designing and fabricating metal building systems for a period of not less than five (5) years. The erector shall be required to have specialized experience in the erection of steel building systems for a period of at least three (3) years. When pre-engineered buildings are used in conjunction with masonry, deflection of the building frame shall be limited to H/600 to prevent cracking of the masonry.

9.7.7 Cold Formed Steel

- (a) Roof Trusses. Generally, cold-formed steel trusses shall be pre-engineered and prefabricated in the manufacturer's plant from system components specifically manufactured for trusses. Trusses designed and fabricated from standard light gauge framing members and field fabricated trusses shall be limited to only minor trusses. The designer shall provide proper truss load diagrams on the drawings. The diagrams shall show the design span length and all appropriate load components. Details showing required bearing conditions and connections shall be shown on the contract drawings. A special specifications section shall be prepared for the cold-formed steel

roof trusses. The truss fabricator shall be required to have a minimum of three years of experience in the production of steel roof trusses. Complete shop drawings showing erection plan, bracing, truss configurations, and truss joint connections shall be required to be submitted for approval.

- (b) Cold-formed steel framing shall be designed in accordance with the current edition of IBC. All cold-formed steel framing shall be formed from steel that conforms to the requirements of ASTM A-653, Grade 33 or higher, having a minimum yield of 33 ksi. Minimum uncoated steel thickness (design thickness times 0.95) shall be 0.0329 inches (20 gauge). All cold-formed steel framing, connectors, etc. shall receive a G60 galvanized coating, as a minimum. Deflection of exterior wall studs supporting masonry shall be limited to $L/600$.

9.7.8 Steel Roof and Floor Deck

Where steel floor and roof deck are used, the required section modulus and moments of inertia shall be shown on the drawings. The type and quantity of decking connectors to be used to resist computed wind uplift and shear diaphragms shall be clearly detailed on the final plans. Steel deck diaphragms shall be designed in accordance with the SDI Diaphragm Manual. All decking shall have a minimum galvanized coating conforming to ASTM A653, G60. Steel roof deck material shall have a minimum thickness of 0.0295 inch (22 gauge). When the underside surface of large areas of steel decking is exposed to view and indicated to be finish painted, the underside surface of the steel decking shall be specified to be factory cleaned and factory primed with a finish paint compatible primer.

9.7.9 Concrete

- (a) Concrete design and detailing shall be in accordance with the IBC except as noted below.
- (b) All edge or spandrel beams shall have continuous reinforcing top and bottom. As a minimum, two #5 bars, top and bottom shall be used. Beams shall have continuous ties at a maximum spacing of 16 inches.
- (c) Slabs on grade shall be designed in accordance with ACI 360 "Design of Slabs on Grade" and ACI 302 "Guide for Concrete Floor and Slab Construction". Slabs-on-grade shall be a minimum of 4 inches thick and reinforced with a minimum of 0.15 percent welded wire fabric, provided in flat sheets, or deformed bars. Reinforcement shall be placed approximately 1-1/2 inches from top of slab. Floor slabs on grade subject to heavy loads may be designed in accordance with UFC 3- 320-06A, "Concrete Floor Slabs on Grade Subjected to Heavy Loads". Control joints for slabs 4"-6" thick shall be spaced a maximum 12.5' on center. Control joints for slabs 6"-9" thick shall be spaced a maximum 15' on center. Control joints for slabs 9"-12" thick shall be spaced a maximum 20' on center. Control joints for slabs 12" and thicker shall be spaced a maximum 25' on center. Slab areas created by crack control joints shall be as near to square as possible; slab area lengths shall not be greater than twice the length. In addition, reentrant corners in slabs and discontinuous joints shall be reinforced with two #4 bars, 4 feet long. Slabs-on-grade to receive moisture sensitive finishes shall be placed on a minimum 15 mil vapor barrier. Control joint reinforcing at joints perpendicular to the line of vehicular travel. Such joints are embedded with #5 x 18" on 12" OC, 1/2 in concrete with the other half as a slip joint.
- (d) Reinforcing of concrete walls, continuous footings, and tie and bond beams shall be

continuous and, therefore, typical details showing the arrangement of reinforcing at corners and intersections of these members shall be shown on the drawings.

9.7.10 Pre-Cast Architectural Concrete

Precast architectural concrete panels shall be configured to prevent notches or excessive cutouts along the perimeter of the panels. Additional reinforcing shall be provided at corners, notches, and cutouts to prevent cracks in the panels. Precast concrete panels shall be waterproofed. Precast concrete panels shall be designed and fabricated by an experienced and acceptable precast concrete manufacturer certified under either the Precast/Pre-stressed Concrete Institute or the National Precast Concrete Association Plant Certification Program. Precast design shall conform to ACI 318/318R and PCI Mnl-122. Precast concrete panels shall be manufactured and cured in accordance with the applicable provision of PCI Mnl-117. Units shall be set true to alignment and level, with joints properly spaced and aligned both vertically and horizontally. Erection tolerances shall be in accordance with the requirements of PCI Mnl-117 and PCI Mnl-122.

9.7.11 Masonry Construction

- (a) Masonry construction shall be designed in accordance with the current revision of the IBC. All structural masonry walls (load bearing walls, shear walls, or exterior walls) shall be designed as reinforced masonry, neglecting the tensile strength of masonry. However, the minimum reinforcement in bond beams and around openings given for structural walls shall be incorporated.
- (b) Minimum thickness of structural masonry walls shall be 8 inches. Minimum bar sizes shall be #4. Minimum reinforcement for structural masonry walls shall be as follows; one vertical reinforcing bar provided continuously from support to support at each wall corner, at each side of each opening, at each side of control joints, at ends of walls, and elsewhere in the wall panels at a maximum spacing of 48 inches. This minimum reinforcing shall be the same size as the vertical reinforcement provided for flexural stresses.
- (c) Horizontal reinforcement in continuous masonry bond beams shall be provided continuously at floor and roof levels and at the tops of walls. Horizontal reinforcement shall also be provided above and below all wall openings. These bars shall extend a minimum of 40 bar diameters, but not less than 24 inches, past the edge of the opening. For masonry laid in running bond, the minimum horizontal reinforcement shall be two #5 bars per bond beam. Lintel units shall not be used in lieu of bond beam units.
- (d) Exterior and interior masonry walls shall have vertical control joints as follows; at changes in wall height or thickness, near wall intersections, at points of stress concentrations, at control joints in foundation walls and control joints in floors that support masonry walls. The maximum vertical control joint spacing is generally recommended to be approximately 24 feet when using horizontal joint reinforcement spaced at 16 inches vertically.
- (e) Particular attention will be given to details for the reinforcement of masonry construction. The horizontal and vertical wall reinforcement and reinforcement around openings and at lintels shall be clearly shown on the structural drawings and coordinated with the sections and details on the architectural drawings. Masonry control joint and expansion joint locations shall be shown on the drawings.

9.7.12 Antiterrorism/Force Protection

Antiterrorism/Force Protection design shall be in accordance with Chapter 18 ANTI- TERRORISM/FORCE PROTECTION (AT/FP).

9.7.13 Required Standard Details

Certain standard structural details are required, as applicable, on all projects. Typical masonry details shall be furnished showing details of horizontal and vertical wall reinforcement, reinforcement around openings and at lintels, and masonry control joints and brick expansion joints.

Chapter 10 - Plumbing

10.1 GENERAL

10.1.1 Scope

This chapter provides guidance for preparation and development of plumbing (including compressed air, fuel gas, and medical gas systems). Specific design submittal requirements in this chapter supplement the requirements in Chapter 1, GENERAL INSTRUCTIONS.

10.2 APPLICABLE PUBLICATIONS

IPC	International Plumbing Code
UPC	Uniform Plumbing Code
UFC	Unified Facilities Criteria
UFC 3-310-04	Seismic Design for Buildings, With Change 1
UFC 3-420-01	Plumbing Systems, With Change 10
UFC 3-420-02FA	Compressed Air, With Change 1
AFI 32-1067	Water and Fuels Systems

Unified Facilities Guide Specifications (UFGS). UFGS are updated on a regular basis.

10.3 PROJECT DEFINITION (10% - 15%)

10.3.1 General Considerations

During the Project Definition design phase, the designer shall define the customer's requirements and confirm that they can be met within the project constraints. To that end, a comprehensive interface with the customer is required generally through a charrette or other previously approved data gathering process. The primary purpose of the design process at this stage is to gather any information from the customer that would be necessary in the design of the facility. Also, the design preferences of the customer should be obtained for compliance if possible.

The general plumbing system type, along with a rough order-of-magnitude estimate of major equipment sizes shall be provided during this phase for use in preparing the cost estimate and sizing the required mechanical spaces.

10.3.2 Narrative

The narrative shall include, but not be limited to, the following items as applicable:

- (a) List all references used in the Design Charrette Narrative including Government design documents, industry standards, safety manuals, and criteria given to designer at the charrette or predesign meeting.
- (b) Explain the proposed type of plumbing system.

- (c) List the major equipment giving rough order-of-magnitude sizes, and piping materials to be used for each system
- (d) Describe any demolition required.
- (e) List any environmental concerns and address actions to be taken.

10.4 CONCEPT DESIGN (30% - 35%)

10.4.1 General Considerations

- (a) During the Concept Design stage of project development, it is recognized that all calculations are preliminary and for analysis purposes and only indicate approximate capacities of equipment. Any dimensions and sizes required are rough-order-of-magnitude figures to ensure adequate space for installation and maintenance of equipment and utility elements such as piping, etc. in congested areas.
- (b) Equipment shown in plans and sections need not be shown in great detail but is shown merely as simple geometric forms with approximate dimensions.
- (c) Piping layouts shown are simple main pipe runs showing general location, routing, and when applicable, rough order-of-magnitude sizes.
- (d) Schematic diagrams are simplified. The purpose of the schematic is only to show system design intent and the basic principle of system operation.
- (e) Plumbing Systems will be designed in accordance with IPC or UPC Illustrated training manual for plumbing other than backflow prevention based on owner's preference and needs. Anything pertaining to backflow prevention and or cross-connection control and installs shall meet or exceed the UPC and AWWA manual M14, Backflow Prevention and Cross Connection Control.

10.4.1.1 Drawings and Sketches. Plans and sections shall properly show pertinent information. Quantity of concept drawings is to be kept to a minimum number required to convey basic systems information. Some mechanical information required in the Concept Submittal may logically be included on other discipline drawings in the design analysis and need not be completed on formal drawings.

10.4.2 Design Analysis

The Concept Design Analysis shall include but not be limited to the following items as applicable:

- (a) List all reference used in the Concept Design including government design documents, industry standards, etc. criteria given to the designer at the pre-design meeting.
- (b) Provide justification and a brief description of the types of plumbing fixtures, piping materials, and equipment proposed for use.
- (c) Prepare basic preliminary calculations for systems such as sizing of domestic water heater and piping, compressed air piping, compressors and receivers, vacuum piping, vacuum pumps and receivers, natural gas piping, and container gas piping and tanks.

- (d) Describe any demolition required.

10.4.3 Specifications

Provide a basic outline in accordance with Chapter 2, SPECIFICATIONS

10.4.4 Drawings

The Concept Design drawings should include, but not be limited to, the following items as applicable:

- (a) Indicate locations and general arrangement of plumbing fixtures and major equipment.
- (b) Indicate location and extent of any demolition that will be required concerning the plumbing system.

10.5 INTERIM DESIGN (50% - 65%)

In addition to the following items, the designer shall incorporate or answer all comments received concerning the Concept Submittal.

10.5.1 Design Analysis

The Interim Design Analysis shall include all items in the Concept Design Analysis and any necessary revisions. In addition, the following specific items shall be included when applicable: Provide detailed calculations for the sizing of the following systems: domestic hot water, domestic cold water, waste and vent, natural and LP gases, vacuum, compressed air, distilled or deionized water, medical gases, and other specialty systems. Identify and address any security requirements.

10.5.2 Specifications

Provide redlined marked-up specifications in accordance with Chapter 2, SPECIFICATIONS.

10.5.3 Drawings

The Interim Drawing should show all information given on the Concept Drawings but in greater detail. In addition, the Interim Drawings should include, but not be limited to, the following items as applicable:

- (a) Include plan and isometric riser diagrams of all areas including hot water, cold water, waste, and vent piping as applicable. Piping layouts and risers should also include natural gas (and meter as required), LP gas, vacuum systems, compressed air systems, distilled or deionized water, medical gases, and other specialty systems as applicable.
- (b) Include equipment and fixture schedules with descriptions, capacities, locations, connection sizes, and other information as required. This includes total peak BTU/hour, connected loads, and delivery pressure.

10.6 FINAL DESIGN (UNREVIEWED 100%)

10.6.1 Design Analysis

The Final Design Analysis shall include all of the information in the Interim Submittal in its final form and incorporate or answer all review comments.

10.6.2 Specifications

Provide specifications if not provided at the Interim Submittal. Provide final edited specifications if an Interim submittal was prepared in accordance with Chapter 2, SPECIFICATIONS.

10.6.3 Drawings

The designer shall incorporate and answer all comments received during the Interim Submittal review. The Final Drawings should be in a Ready-to-Advertise state which should include, but not be limited to, the following items as applicable.

- (a) Plans, sections, details, and riser diagrams in final condition.
- (b) Complete all legends and schedules.
- (c) Complete all narratives, notes, and title blocks as necessary.

10.7 READY-TO-ADVERTISE (REVIEWED 100%)

The comments generated concerning the Final Submittal shall be incorporated in the design analysis, specifications, and drawings before they are submitted as “Ready-to-Advertise”.

10.8 TECHNICAL REQUIREMENTS

10.8.1 General Considerations

- (a) Coordinate space requirements, foundations, supports, pipe routing, electrical service, and the like for mechanical items with architectural, structural, and electrical design elements. Coordinate exterior mechanical distribution systems with design elements handling other exterior utility designs and site work.
- (b) Standard or “packaged” equipment shall be used to the greatest extent possible to simplify specifying, purchasing, installation, and maintenance of equipment.
- (c) UFC 3-420-01 is the prime design manual supplemented by the International Plumbing Code.

10.8.2 Plumbing Considerations

- (a) Piping System. Piping materials and sizes shall comply with the recommendations in the IPC and UFC 3-420-01. Flow velocities in water pipe shall not exceed 10 feet per second. All piping shall be sloped to permit drainage and shall be properly supported with allowances for expansion and contraction. Expansion loops or expansion joints and anchor points shall be shown on plumbing drawings. Piping subject to freezing shall be suitably protected.
- (b) Wall Hydrants and Lawn Faucets. The maximum spacing between wall hydrants or between lawn faucets around the perimeter of a building is 200 feet. Add 5 gpm for each hydrant or faucet to building load for sizing water main.

- (c) Floor Drains. Floor drains shall be provided in all boiler and mechanical equipment rooms and adjacent to each indoor emergency deluge shower. Provide trap primers for all floor drains unless specified otherwise. Floor drains are not allowed in rooms used as plenums.
- (d) Backflow Prevention. The water distribution system shall be protected against the flow of water or other liquids into the distributing pipes from any unintended source or sources. Refer to the IPC for requirements on all systems.
- (e) Domestic Hot Water. In the design of any buildings in which water closets or showers are installed, the designer shall exercise the necessary precautions to prevent personnel from being scalded while taking showers due to simultaneous operation of water closets equipped with flush valves.
 - (1) Domestic Hot Water Temperature. Domestic hot water supply maximum temperatures at the point of use will be as follows for the indicated facilities or areas unless higher temperatures are required for sanitizing or special processes.
 - a. In all latrines, heads, and toilet facilities without showers or tubs, the actual measured temperature of hot water delivered to the user shall not exceed 130°F.
 - b. In all latrines, heads, and toilet facilities with showers or tubs, the actual measured temperature of hot water delivered to the user shall not exceed 120°F.
 - c. In buildings such as bachelor officer quarters (BOQ) and bachelor enlisted quarters (BEQ) where there may be toilet facilities both with and without showers or tubs, where there is both heavy and frequent use of the bathing facilities, where there is a common hot water supply system, the delivered temperature of 120°F may be used for all facilities.
 - d. In buildings such as administrative, where showers are provided only in a few special cases, such as for the commanding officer and duty officer, the delivered water temperature shall not exceed 120°F. The same condition shall prevail in laboratory and special buildings where showers are provided for emergency or exceptional use, or where the number of users or frequency of use is low.
 - (2) It is recognized that in some older buildings or in some unusual cases, it may be necessary to do more than reset existing temperature controllers. In some cases, added storage tanks, temperature blending equipment, or separate lines might be required.
- (f) Sump Pumps. Sump pumps shall be provided in areas that do not have a way for gravity drainage.
- (g) Compressed Air. Unless requirements are stated in specific instructions, compressed air systems and air compressor sizes will be determined by the designer from analysis of equipment layout and/or coordination with UFC 3-420- 02FA.

- (h) Equipment Schedules. Each set of drawings for a project or building shall include one or more fixture schedules that will designate the symbols, P numbers, outfit numbers, description, and sizes of connections.
- (i) Plumbing shall not traverse over or under electrical panels or switchboards.

10.8.3 Seismic Protection

All piping, equipment, and utilities shall be protected in accordance with UFC 3-310-04.

Chapter 11 - Heating, Ventilating and Air Conditioning

11.1 GENERAL

11.1.1 Scope

This chapter provides guidance for the preparation and development of the following design aspects; heating, ventilating, air conditioning (including chilled water and dual temperature water distribution systems). Specific design submittal requirements in this chapter supplement the requirements in Chapter 1, GENERAL INSTRUCTIONS.

11.2 APPLICABLE PUBLICATIONS

Energy Policy Act of 2005 (EPACT 05) (Public Law 109-58)

IMC International Mechanical Code

IFGC International Fuel Gas Code

IPC International Plumbing Code

Unified Facilities Criteria (UFC)

UFC 3-310-04 Seismic Design for Buildings, With Change 1

UFC 3-410-01 Heating, Ventilating, and Air Conditioning Systems, With Change 4

UFC 1-200-02 High Performance and Sustainable Building Requirements, With Change 1

UFC3-400-01 Design: Energy Conservation

American Society of Heating, Refrigeration, and Air Conditioning Engineers, Inc. (ASHRAE)

Sheet Metal and Air Conditioning Contractors National Association (SMACNA)

Unified Facility Guide Specifications (UFGS). UFGS are updated on a regular basis.

11.3 ENERGY CONSERVATION

The building HVAC systems shall be designed in accordance with ASHRAE 90.1 and UFC 1-200-02. The criteria provide mandatory and prescriptive criteria that must be followed to provide an energy efficient facility. In addition, the design shall meet the applicable requirements of EPACT 05.

11.4 PROJECT DEFINITION (10% - 15%)

11.4.1 General Considerations

- (a) During Project Definition the designer must define the customer's requirements and confirm that they can be met within the project's constraints. To that end, a

comprehensive interface with the customer is required generally through a charrette or other previously approved data gathering process. The primary purpose of the design process at this stage is to gather any information from the customer that would be necessary in the design of the facility. Also, the design preferences of the customer should be obtained for compliance if possible.

- (b) The general HVAC system type and purpose along with a rough-order-of- magnitude estimate of major equipment sizes shall be provided at this phase for use in preparing the cost estimate and sizing the required mechanical spaces.

11.4.2 Narrative

- (a) List all references used in the Design Charrette Narrative including Government design documents, industry standards, safety manuals, and criteria given to designer at the charrette or predesign meeting.
- (b) Explain the purpose and proposed type of environmental system (i.e. personnel comfort, process, or computer cooling, freeze protection or otherwise).
- (c) List mandatory and prescriptive HVAC features to be included in the design as required by ASHRAE 90.1 and UFC 1-200-02 to provide an energy efficient facility.
- (d) State the design conditions including the indoor and outdoor temperatures, relative humidities for summer and winter conditions, filtration and ventilation requirements, personnel loads, special equipment loads, etc.
- (e) State the proposed building characteristics including “U” Factors of walls, floors, roofs, windows, etc., orientation of the building, latitude and longitude of location, and any special conditions that would have an impact on HVAC design.
- (f) List the major equipment and give the sizes in general order-of-magnitude.
- (g) Briefly describe the proposed control system type.
- (h) Discuss requirements for natural gas, fuel oil, and water flow meters.
- (i) Describe any required demolition.
- (j) List Anti-Terrorism/Force Protection, Sustainable Design, and Seismic Protection concerns.

11.5 CONCEPT DESIGN (30% - 35%)

11.5.1 General Considerations

- (a) During the Concept Design stage of project development, it is recognized that all calculations are preliminary for analysis purposes and only indicate approximate capacities of equipment. Any dimensions and sizes are rough-order-of-magnitude figures to assure adequate space for installation and maintenance of equipment and utility elements such as piping, ductwork, etc., in congested areas.

- (b) Equipment shown in plans and sections need not be shown in great detail but shown merely as simple geometric forms with approximately correct dimensions.
- (c) Piping layouts shown are simple main pipe runs showing general location, routing and, when applicable, approximate order-of-magnitude sizes. Control valves, check valves, etc. are shown only as required to indicate function of the system. Only routing of main headers feeding batteries of water coils need be shown, not individual lines to coils unless required for clarity of the system.
- (d) Schematic diagrams are simplified. System flow diagrams, layouts, and one of each type of take-off, branch, or feed must be shown but not all individual branches. The purpose of the schematic is only to show system design intent and the basic principle of system operation.
- (e) Plans and sections need be only large enough to properly show pertinent information. Quantity of concept drawings are to be kept to a minimum number required to convey basic system information. Some mechanical information required in the Concept Submittal may logically be included on other discipline drawings in the design analysis and need not be completed on formal drawings.
- (f) Throughout the design submittals and on the Ready-To-Advertise drawings, abbreviations used on drawings shall conform to ASHRAE Fundamentals and shall be indicated in mechanical drawing legend.

11.5.2 Design Analysis

The Concept Design Analysis shall include, but not be limited to, the following items as applicable:

- (a) List all references used in the Concept Design including Government design documents, industry standards, safety manuals, criteria give to the designer at the predesign meeting, etc.
- (b) Explain the purpose of the environmental system (i.e., personnel comfort, process or computer cooling, freeze protection, or otherwise).
- (c) List mandatory and prescriptive HVAC features to be included in the design as required by ASHRAE 90.1, UFC 1-200-02 and EPACT 05 to provide an energy efficient facility.
- (d) State the design conditions including indoor and outdoor temperatures, relative humidities for summer and winter conditions, filtration and ventilation requirements, personnel loads, special equipment loads, etc.
- (e) State building characteristics including “U” Factors of walls, floors, roofs, windows, etc. orientation of the building, latitude and longitude of location, and any special conditions that would have an impact on HVAC design.
- (f) Prepare basic calculations such as typical room loads, block loads for heating and cooling systems, approximate cfm, gpm (or applicable units) quantities, and a balance flow diagram showing quantities of air handled and circulated throughout each building as a whole (including quantities for outside and exhaust air).

- (g) Briefly describe the proposed sequence of control for temperature, humidity, ventilation, etc.
- (h) Discuss requirements for natural gas, fuel oil and water flowmeters.
- (i) Describe any required demolition.
- (j) Provide a basic outline specification in accordance with Chapter 2 SPECIFICATIONS.
- (k) Describe actions to be taken to address Antiterrorism/Force Protection, Sustainable Design, and Seismic Protection concerns.

11.5.3 Drawings

The Concept Design drawings should include, but not be limited to, single-line layouts of heating and air conditioning systems showing equipment and contemplated zoning for each building. Drawings shall identify rooms and be sufficiently complete to show the location, arrangement, approximate capacities of all major systems of equipment, and space allocated for servicing and maintenance. Include the following items:

- (a) Single-line layouts of HVAC systems with preliminary representative duct sizes of main runs and quantities. This includes exhaust systems and make-up air systems. Representative sections of ducts in congested areas should be shown double line.
- (b) Show required maintenance space for all major equipment, preferably with dashed lines.
- (c) Show major piping single line with approximate size.
- (d) Indicate preliminary approximate capacities of all major equipment, including horsepower of motors, KW of major electric heating elements, cfm of major air handlers, cooling and heating capacities, etc.
- (e) Indicate location and extent of any demolition that will be required concerning the HVAC system.

11.6 INTERIM DESIGN (50% - 65%)

In addition to the following items, the designer shall incorporate or answer all comments received during the Concept Design submittal review.

11.6.1 Design Analysis

The Interim Design analysis shall include all items in the Concept Design analysis and any necessary revisions. In addition, the following specific items shall be included when applicable:

- (a) Provide detailed calculations for the following: heating loads, cooling loads, equipment sizing, etc. Computer calculations shall include printout of input data as well as output.

- (b) Equipment Selection: Equipment selection shall be based on not less than three manufacturers whose equipment meets the project requirements for each item. The design analysis shall include catalog cuts of all major equipment (e.g. air handlers, coils, chillers, condensing units, boilers, pumps, fans, unit heaters, heat exchangers, etc.) used as the basis of design indicating manufacturer, model number, dimensions, capacities, and electrical requirements. The project design is not complete until the designer is assured that there is sufficient physical space in areas where equipment is to be located to install and to maintain the selected equipment.
- (c) Include any other information or calculations to verify that the design complies with applicable criteria codes or standards and is satisfactory for intended purposes.
- (d) Major unforeseen costs and any changes from Concept Submittal shall be referenced and the impact on energy efficiency shall be indicated. Justification for departures, if any, from the original design recommendations shall be provided.
- (e) Explanatory notes shall be provided in the design analysis covering all rationale for design which would be obvious to an engineer reviewing the analysis. Methods of air conditioning and controls for air conditioning systems shall generally be confined to those in common use in the industry.
- (f) Specifications: The outline specifications previously submitted for concept phase shall be revised, updated, further developed, and resubmitted in accordance with Chapter 2 SPECIFICATIONS.

11.6.2 Drawings

The Interim drawings should show all information given on the Concept drawings but in greater detail. In addition, the Interim drawings shall include, but not be limited to, the following items as applicable:

- (a) Show all ductwork and piping, with sizes and flow rates, where necessary for balancing purposes. Indicate the ductwork pressures in accordance with Sheet Metal and Air Conditioning Contractor's National Association (SMACNA) standards. Include all accessories and appurtenances.
- (b) Show temperature control schematics indicating remote sensors, panel mounted controllers, reset schedules if applicable and thermostats.
- (c) Show layout and details of the final version of all HVAC systems. The location, arrangement, capacity, and space requirements of all equipment shall be indicated. Selected zones of air distribution shall be sufficiently completed to indicate the solution of the design for the remainder of the system and the precautions taken to coordinate the design with architectural, structural, and electrical phases of construction. Equipment room layouts shall be sufficiently complete to show piping and duct layouts and access for maintenance. Since equipment rooms represent the most congested areas for both equipment and piping, the following guidelines should be considered when preparing the drawings:
 - (1) Pipe fittings and accessory details shall be shown.
 - (2) All duct and fittings in congested areas and mechanical rooms shall be drawn

to scale using double-line layouts. In a VAV system, ducts between the air handling unit (AHU) and the variable air volume (VAV) boxes shall be double-lined and ducts downstream of the VAV boxes may be single-lined.

- (3) All equipment shall be outlined to scale, and maintenance or removal space shall be indicated by dashed lines.
- (d) Show new exterior chilled water, dual temperature water, or steam distribution systems from central energy plants in plan and profile. Show all other exterior piping in plan.
- (e) The final form of all equipment schedules shall be shown with preliminary equipment data filled in.

11.6.3 Specifications

Provide redlined, marked-up specifications in accordance with Chapter 2 SPECIFICATIONS.

11.7 FINAL DESIGN (UNREVIEWED 100%)

Comments generated during the Interim Design submittal review shall be incorporated or answered in the design analysis, specifications, and drawings before they are submitted as “Final”.

11.7.1 Design Analysis

The Final Design Analysis shall include all the information required in the Interim Design submittal in its final form and the information listed below as applicable:

- (a) Include flow diagrams with all quantities for both air and water sides of complex HVAC systems for balancing purposes (including all kitchens with commercial hood systems).
- (b) Major unforeseen costs and any changes from Interim or Concept Submittals shall be referenced and impact on energy and economic studies shall be indicated. Justification for departures, if any, shall be provided.
- (c) The designer shall review the prepared plans and specifications and determine that they are in accordance with these base standards and all other criteria and provided instructions. It will be the responsibility of the designer to coordinate the HVAC systems with the other trades involved in the building design and to eliminate interference between HVAC equipment and other components of the building.

11.7.2 Specifications

Provide specifications if not provided at the Interim submittal. Provide final edited specifications if an Interim submittal was prepared in accordance with Chapter 2 SPECIFICATIONS. The specifications shall be edited and tailored by the designer to meet the requirements of the project under design. The Contractor Submittal Register must be edited and included.

11.7.3 Drawings

The Final drawings should be in a Ready-to-Advertise state which should include, but not be limited to, the following items as applicable:

- (a) Include all plans, sections, and details in final condition.
- (b) Include all completed legends and schedules.
- (c) Show all necessary piping schematics in final form.
- (d) Complete narratives, notes, and title blocks as necessary.
- (e) Show all temperature control systems as follows:
 - (1) Location of sensors, thermostats, and control panels.
 - (2) Schematics, diagrams, layouts, legends, narratives, sequences, etc. of the Direct Digital Control System.
 - (3) Note: Compatibility with any existing basewide control systems must be ensured.

11.8 READY-TO-ADVERTISE (REVIEWED 100%)

Comments generated during the Final Design submittal review shall be answered or incorporated in the design analysis, specifications, and drawings before they are submitted as Ready-To-Advertise.

11.8.1 Specifications

The designer shall prepare the final detailed Technical Provisions of the specifications in accordance with Chapter 2 SPECIFICATIONS.

11.9.1 Seismic Protection

All piping, equipment, and utilities shall be protected in accordance with UFC 3-310-04.

Chapter 12 - Fire Suppression System

12.1 GENERAL

12.1.1 Scope

This chapter provide guidance for preparation and development of the fire suppression systems. Specific design submittal requirements in this chapter supplement the requirements in Chapter 1 GENERAL INSTRUCTIONS.

12.2 APPLICABLE PUBLICATIONS

Unified Facilities Criteria

UFC 3-600-01 Fire Protection Engineering for Facilities, With Change 2

UFC 3-310-04 Seismic Design for Buildings, With Change 1

UFC 4-211-01 Aircraft Maintenance Hangars, with Change 1

UFC 4-211-02 Aircraft Corrosion Control and Paint Facilities

National Fire Protection Association (NFPA)

Latest Edition National Fire Codes

Unified Facilities Guide Specifications (UFGS)

UFGS are updated on a regular basis. Instructions on retrieving UFGS are covered in Chapter 2 SPECIFICATIONS.

AFI 32-1067 Eglin AFB Supplement Water and Fuel Systems

DAFMAN 91-203 Air Force Occupational Safety Fire and Health Standards

12.3 PROJECT DEFINITION (10% - 15%)

12.3.1 General Considerations

During this phase, the designer must define the customer's requirements and confirm that they can be met within the project's constraints. To that end, a comprehensive interface with the customer is required generally through a charrette or other previously approved data gathering process. The primary purpose of the design process at this stage is to gather any information from the customer that would be necessary in the design of the facility.

The general fire suppression system type and purpose along with a rough order-of-magnitude estimate of major equipment sizes shall be provided at the Design Charrette Phase for use in preparing the cost estimate and, sizing shall be determined as early as possible to ensure that the associated costs are included in the earliest estimate.

12.3.2 Narrative

The narrative shall include, but not be limited to, the following items as applicable:

- (a) List all references used in the Design Charrette Narrative including government design documents, industry standards, safety manuals, criteria given to the designer at the Charrette or pre-design meeting.
- (b) Explain the proposed type of fire suppression system and if a fire pump and/or storage tank is required.
- (c) Describe any required demolition.
- (d) List any environmental concerns and address actions to be taken.

12.4 CONCEPT DESIGN (30% - 35%)

12.4.1 General Considerations

During the Concept Design Phase of project development, it is recognized that all calculations are preliminary for analysis purposes and only indicate approximate capacities of equipment; however, calculations must be adequate to determine whether fire pumps and/or storage tanks are required. Any dimensions or sizes required are rough-order-of-magnitude figures to assure adequate space for installation and maintenance of equipment and utility elements such as piping in congested areas.

Equipment shown in plans and section is not to be shown in great detail but is shown merely as a simple geometric form with approximately correct dimension.

If required, piping layouts shall be shown as simple main pipe runs indicating general location, routing and, when applicable, approximate order-of-magnitude sizes.

12.4.1.1 Drawings and Sketches

Quantity of Concept Drawings are to be kept to the minimum number required to convey basic system information. Some mechanical information required in the Concept Submittal may logically be included on other discipline drawings in the design analysis and need not be completed on formal drawings.

12.4.2 Design Analysis

The Concept Design Analysis shall include, but not be limited to, the following items as applicable:

- (a) List all references used in the Concept Design including Government design documents, industry standards, criteria given to the designer at the pre-design meeting, etc.
- (b) Classify each building in accordance with the following:
 - (1) Fire zone
 - (2) Building floor areas.
 - (3) Height and number of stories.

- (c) Discuss and provide description of required fire protection including extinguishing equipment, detection equipment, alarm equipment and water supply.
- (d) If water sprinkler systems are to be provided, preliminary hydraulic calculations shall be prepared for the most hydraulically demanding area to ensure that flow and pressure requirements can be met with current water supply. The Engineer of Record shall conduct their own fire flow test as required to complete the design of the fire suppression system.
- (e) Identify any special security requirements.

12.4.3 Specifications

Provide a basic outline in accordance with Chapter 2 SPECIFICATIONS.

12.4.4 Drawings

The Concept Design drawings shall include, but not be limited, the following items as applicable:

- (a) The location and rating of any fire-resistant construction such as occupancy separations, area separations, exterior walls, shaft enclosures, corridors, stair enclosures, exit passageways, etc.
- (b) The location and coverage of any fire suppression systems (e.g. sprinkler risers, standpipes, etc.).
- (c) Indicate any hazardous areas and their classification.
- (d) Provide description of type sprinkler system to be provided (e.g. dry pipe, pre-action, wet pipe, AFFF, etc.).
- (e) Address security requirements (e.g., dielectric couplings, grounding, etc.).

12.5 INTERIM DESIGN (50% - 60%)

In addition to the following items, the designer shall incorporate or answer all comments received concerning the Concept Submittal.

12.5.1 Design Analysis

Provide a detailed description of the system and its controls such as activation of system, interlocks with HVAC system and connection to detection and alarm systems.

12.5.2 Specifications

Provide redlined marked-up specifications in accordance with Chapter 2 SPECIFICATIONS.

12.5.3 Drawings

The Interim Drawings should show all information given in the Concept Drawings but in greater detail. In

addition, the Interim Drawings should include, but not be limited to, the following as applicable:

- (a) Include items shown on the concept drawings and any necessary revisions.
- (b) Prepare a schedule describing the system with the following information: fire hazard and occupancy classification, building construction type, GPM/square foot sprinkler density, area of operation, hose stream allowances and other as required.
- (c) Provide drawings showing a rough layout of the main piping involved in the sprinkler system if applicable.

12.6 FINAL DESIGN (UNREVIEWED 100%)

In addition to the following items, the designer shall incorporate or answer all comments received during the Interim Submittal review.

12.6.1 Final Design Analysis

The Final Design Analysis shall include all the information required in the Interim submittal in its final form and incorporation of, or answers to, all comments received concerning the Interim submittal.

12.6.2 Specifications

- (a) Provide specifications if not provided at the Interim submittal. Provide final edited specifications if an Interim submittal was prepared in accordance with Chapter 2 SPECIFICATIONS. Specifications used shall be those acquired after the Interim submittal.
- (b) Specifications for fire suppression systems shall be performance type, except when aircraft hangars require specifically designed sprinkler systems, listing hazards, minimum water densities, minimum area of operation, water flow test data and any other data necessary for the construction contractor to design the system.

12.6.3 Drawings

The final drawings for sprinkler systems should be in a Ready-To-Advertise state which should include, but not be limited, the following items as applicable.

- (a) Include plans in final condition.
- (b) Complete all legends and schedules.
- (c) Complete all narratives, notes, and title blocks as necessary.

12.7 READY-TO-ADVERTISE (REVIEWED 100%)

The comments concerning the Final submittal shall be answered or incorporated in the design analysis, specifications, and drawings before they are submitted as “Ready-To-Advertise”.

Chapter 13 - Other Mechanical Systems and Equipment

13.1 GENERAL

Specific design submittal requirements in this chapter supplement the requirements in Chapter 1 GENERAL INSTRUCTIONS. Requirements of this chapter pertain to the following mechanical systems and equipment.

- (a) Petroleum, Oils and Lubricant (POL) Facilities / Automotive and Aircraft Fueling Systems.
- (b) Diesel Engines for Generators and Fire Pumps.
- (c) Cranes and Hoists
- (d) Storage Tanks
- (e) Central Energy Plants and Distribution System
- (f) Elevators
- (g) Other Mechanical Systems

13.2 APPLICABLE PUBLICATIONS

International Building Code (IBC)

Unified Facilities Criteria (UFC)

UFC 3-460-01 Design: Petroleum Fuel Facilities, With Change 3

UFC 1-200-02 High Performance and Sustainable Building Requirements, With Change 1

UFC 3-430 Series Design: Central Energy Plants and Distribution Systems

General Criteria

ASME American Society of Mechanical Engineers – Codes and Standards

ANSI American National Standards Institute – Codes and Standards

AWS American Welding Society – Codes and Standards

API American Petroleum Institute – Standards and Publications

NFPA National Fire Protection Association – Codes

Cranes and Hoists

CMAA No. 70 Crane Manufacturers Association of America Specification for Electric Overhead Traveling Cranes.

CMAA No. 74 Crane Manufacturers Association of America Specification for Top Running Single Girder Electric Overhead Traveling Cranes

Elevators

ASME A17.1 Safety Code for Elevators and Escalators

Unified Facilities Guide Specifications (UFGS)

UFGS are updated on a regular basis. Instruction for retrieving UFGS are provided in Chapter 2, SPECIFICATIONS.

13.3 PROJECT DEFINITION (10-15%)

13.3.1 General Considerations

During this design phase, the designer must define the customer's requirements to confirm that they can be met with the project's constraints. To that end, a comprehensive interface with the customer is required generally through a charrette or other previously approved data gathering process. The primary purpose of this design phase is to gather any information from the customer that would be necessary in the design of the facility. Also, the design preferences of the customer should be obtained for compliance if possible.

The general mechanical system types and purposes along with a rough-order-of-magnitude of major equipment sizes will be estimated at the Design Charrette phase for the purpose of generating a parametric cost estimate and required mechanical spaces.

13.3.2 Narrative

The narrative shall include, but not be limited to, the following items as applicable:

- (a) List all references used in the Design Charrette narrative including Government design documents, industry standards, safety manuals, criteria given to the designer at the charrette, pre-design meeting, etc.
- (b) Describe the proposed type of mechanical system.
- (c) Describe any demolition required.
- (d) List any environmental concerns and address actions to be taken.
- (e) Describe proposed construction planning of mechanical system for alteration/modification projects.

13.4 CONCEPT DESIGN (30-35%)

13.4.1 Design Analysis

The following specific items shall be included where applicable:

- (a) A list of all special mechanical systems and equipment in the project.
- (b) A list of criteria, codes, documents, and design conditions used. Reference to any authorized waiver of these criteria or codes.
- (c) Logic establishing the need for the system. If necessary, a life-cycle cost estimate for all systems considered and a statement of justification for selection of the final system.
- (d) Preliminary sizes of equipment, piping, and space required for the equipment and distribution methods selected.
- (e) A description of the proposed control system.
- (f) Description, approximate capacity, and location of any special mechanical equipment such as elevators, cranes, lifts, etc.
- (g) Description of the various types and quantities (supported by calculations as applicable) of POL products and their associated unloading, storage, and dispensing systems.
- (h) Phasing

13.4.2 Drawings

The following specific items shall be shown where applicable:

- (a) Flow diagrams of all systems proposed. These diagrams shall be an accurate schematic representation of the system, showing all proposed equipment, piping, control valves, and primary control loops. In addition, the drawings shall indicate approximate capacities of equipment, flow rates in mains, branches, and outlets, direction of slope for pipe, and shall identify the location of equipment by building and room.
- (b) Plans sufficiently complete to show the location and general arrangement of mechanical equipment and major piping. Piping may be shown with single lines.

13.4.3 Specifications

Provide a basic outline in accordance with Chapter 2, SPECIFICATIONS.

13.5 INTERIM DESIGN (50-60%)

In addition to the following items, the designer shall incorporate or answer all comments received concerning the Concept Design submittal.

13.5.1 Design Analysis

The Interim Design analysis shall include all items into Concept Submittal and any necessary revisions. In addition, the following specific items shall be included when applicable:

- (a) Detailed calculations for sizing equipment.

- (b) Detailed logic diagrams for control schemes used.
- (c) Any other information or computation required to verify that the design complies with the design criteria, codes, and standards, and is satisfactory for the intended purposes.

13.5.2 Drawings

The following specific items shall be shown when applicable:

13.5.2.1 Flow Diagrams of Systems (where applicable)

These diagrams shall show all the information given on the Concept drawings, but in greater detail. The diagrams shall include equipment capacities and power requirements, all piping sizes with flow rates indicated, all valves, piping specialties, instrumentation, and control devices.

13.5.2.2 Plans and Sections

Layouts and details of the final version of the proposed system showing location, arrangement, capacity and space requirements of all equipment plus size, elevations, supports, product identification and direction of flow for all piping.

13.5.2.3 Equipment

The drawings shall include space for rating data in tabular form for all items of equipment, with space reserved for designating the manufacturer and the model number, in anticipation of as-built drawings. Preliminary rating data shall be inserted in the equipment schedules at this stage. Equipment schedules shall be completed when final rating data are established but not later than the Final Review submission.

13.5.3 Specifications

Provide redlined, marked-up specifications in accordance with Chapter 2, SPECIFICATIONS.

13.6 FINAL DESIGN (UNREVIEWED 100%)

Comments generated during the Interim Design Submittal shall be incorporated or answered in the design analysis, specifications, and drawings before they are submitted as “Final”. The design analysis shall be complete. The final drawings shall be in a “Ready-To-Advertise” state. Provide specifications if not provided at the Interim submittal. Provide final edited specifications if an Interim submittal was prepared in accordance with Chapter 2, SPECIFICATIONS. A technical specification is required for each mechanical system or piece of equipment covered in this chapter.

13.7 READY-TO-ADVERTISE (REVIEWED 100%)

The comments generated during the Final Design Submittal shall be answered or incorporated in the design analysis, drawings and specifications before they are submitted as Ready-To-Advertise.

13.8 TECHNICAL REQUIREMENTS

13.8.1 POL Facilities

POL facilities shall be designed in accordance with UFC 3-460-01, Petroleum Fuel Facilities.

13.8.2 Engine-Generators

Diesel engine-generators shall be designed in accordance with instructions given in applicable Guide Specifications and the applicable portions of this text.

13.8.2.1 Facilities for Engine-Generators

Engine-generator buildings or rooms designed for engine-generator installation shall be designed to support the unit with the following:

- (a) Sufficient cooling and combustion air supply and exhaust.
- (b) Correct air flow patterns to optimize cooling of both generator and engine.
- (c) Door width and height to allow installation and removal of sets.
- (d) Floor space for starting batteries, charger, and working space around the set, fuel oil supply and return piping trenches, day tank, electrical equipment, etc.
- (e) Height of building to accommodate diesel engine, exhaust pipe, muffler, and insulation. Materials should be selected for exterior piping to resist rusting or corrosion to prevent discoloration of the building exterior.
- (f) Size of building roof framing to accommodate suspension or installation of engine exhaust system. Materials should be selected for exterior piping to resist rusting or corrosion to prevent discoloration of the building exterior.
- (g) Sufficient inside building temperature for engine to be maintained with jacket water heaters at required starting temperature.

A scaled drawing is required for all diesel-generator sets and shall show each set and the above-mentioned appurtenances.

13.8.3 Cranes and Hoists

13.8.3.1 Hoists

Hoists shall be shown on the drawings in both plan and elevation views. The following items shall be shown to scale and dimensioned on the drawings:

- (a) Length, size, and location of monorail.
- (b) Location, degree, and radius of all monorail curves.
- (c) Location of all monorail track switches.
- (d) Minimum acceptable hook height: i.e., distance from finished floor to saddle of hoist hook in raised position.

These items can be shown on architectural, structural, or a separate mechanical drawing. If additional specifications are required, recognized standards shall be used.

13.8.3.2 Overhead Traveling Cranes

A crane clearance diagram is required for all traveling cranes. The required limits of crane hook travel in both plan and elevation and the dimensions of an envelope reserved for installation of the crane shall be shown on the drawing. For envelope dimensions, an overhead clearance of 3 inches above the high point of the crane is satisfactory. Between the crane and the sidewalls of the building, a clearance of 4 to 6 inches is adequate. Details of special features, such as pickup beams, control outriggers, special hooks, trolleys, hoist, end trucks, etc. shall also be shown on this drawing.

13.8.3.3 Special Hoists and Cranes

Special hoists and cranes that are not monorail or overhead traveling type shall be treated as special designs. Design requirements for these special cranes shall be requested through project management to the appropriate technical section at or before the predesign conference.

13.8.3.4 Coordination With Heating Systems

Hoists and cranes must be coordinated with the heating and ventilating systems. If infrared heating is used in the area where the crane is located, provide a shield for the top of the crane to protect it from the infrared heaters.

13.8.4 Storage Tanks for Petroleum, Oils, and Lubricants

Tanks shall be vertical or horizontal and either above ground, or underground. For tanks with a volume of 40,000 gallons or less, preference shall be given to tanks of the shop-fabricated horizontal type. Tanks with a volume larger than 40,000 gallons shall be aboveground, vertical, fixed-roof with floating pan, as required by project criteria. Gasoline storage tanks that will have a dispensing throughput 10,000 gallons/month or greater must meet design requirements established in 40 CFR Part 63 Subpart CCCCC Gasoline Dispensing Facilities.

13.8.4.1 Above Ground tanks

Tanks shall be designed in accordance with UFC 3-460-01, the latest editions of API-650 and NFPA-30. Tanks to be rehabilitated or modified shall be in accordance with API-653. All aboveground tanks shall have spillage containment dikes.

13.8.4.2 Underground tanks

Tanks shall be designed in accordance with UFC 3-460-01 and NFPA-30. Tanks with volumes of 40,000 gallons or less shall be double-wall, horizontal and suitable for underground installation. Tanks shall be either of fiberglass reinforced plastic construction or of steel construction. Steel tanks shall be coal tar or epoxy coated and provided with a cathodic protection system or coated with glass fiber-reinforced polyester resin coating. All storage tanks shall be monitored by a leak detection system. The leak detection system shall indicate, by an audible alarm and indicator lights, the occurrence of a leak in either tank shell. The system shall be of the electronic monitoring, pressure monitoring, vacuum monitoring, or liquid monitoring type. Observation wells shall be provided in areas of seasonal high groundwater where the tank is anchored in the groundwater during normal operation. The wells may employ any of the types of leak detectors mentioned above to provide continuous monitoring. All observation wells shall be clearly identified and provided with locking devices. Tanks with volumes of more than 40,000 gallons shall be vertical, and field erected unless otherwise authorized.

13.8.5 Central Energy Plants and Energy Distribution Systems

Central energy plants and energy distribution systems shall be designed in accordance with the UFC 3-430 series of criteria.

13.8.6 Elevators

Elevator systems shall be designed in accordance with the UFC and ASME A17.1, Safety Code for Elevators.

13.8.7 Other Mechanical Systems

All other mechanical systems shall be designed In accordance with the latest and most stringent design criteria as listed in the contract scope of work.

Chapter 14 - Electrical and Electronic Systems

14.1 GENERAL

14.1.1 Scope

This chapter gives general guidelines for the preparation of drawings, specifications, and design analysis as related to Interior Electric, Exterior Lighting, Emergency and Standby Generators. Eglin specific requirements concerning grounding, and electronic systems including security (Access Control (ACS) and Intrusion Detection (IDS)) and fire alarm systems are included in Appendix 4. Specific design submittal requirements in this chapter supplement the requirements in Chapter 1 GENERAL INSTRUCTIONS. All primary electrical systems shall be in accordance with the current CHELCO specifications.

14.1.2 Design Submittals

- (a) The following submittal guidelines have been developed for the most common projects such as a building or buildings. Projects with complicated or highly-technical interior electrical work will have special submittal requirements developed for that project.
- (b) Special requirements shall be defined, developed, and agreed upon at the predesign conference and will become a part of the contract.
- (c) Design submittals will be reviewed for general compliance with criteria. Some detailed checks will be made. Complete and independent checking of the design should be accomplished by the designer. The designer is fully responsible for the design. The design shall be complete and accurate. It should be thoroughly checked for errors, conflicts (both within and between disciplines), and proprietary requirements. No proprietary restrictions may be included in the contract unless specifically authorized.

14.2 APPLICABLE PUBLICATIONS

American National Standard Institute (ANSI)

IEEE-C2 National Electric Safety Code

Institute of Electrical and Electronic Engineers (IEEE)

IEEE 142 Recommended Practice for Grounding of Industrial and Commercial Power Systems.

Instrument Society of America (ISA)

ISA 55.1 Instrumentation Symbols and Identification

ISA 55.2 Binary Logic Diagrams for Process Operations

National Fire Protection Association (NFPA)

NFPA 70	National Electric Code
NFPA 70E	Standard for Electrical Safety in the Workplace
NFPA 72	National Fire Alarm Code
NFPA 90A	Standard for the Installation of Air-Conditioning and Ventilating Systems.
NFPA 101	Life Safety Code
NFPA 170	Standard for Fire Safety and Emergency Symbols
NFPA 730	Guide for Premises Security
NFPA 780	Standard for the Installation of Lightning Protection Systems
National Electrical Manufacturers Association (NEMA)	
NEMA E1 13	Pulse Initiators for Watthour and Other Integrating Meters
Military Handbooks (MIL-HDBK)	
MIL-HDBK 419A	Military Handbook Grounding, Bonding and Shielding for Electronic Equipment and Facilities
MIL-HDBK 1190	Military Handbook for Facility Planning and Design Guide
MIL-HDBK 1191	Military Handbook for Medical and Dental Treatment Facilities, Design and Construction Criteria Guide
MIL-HDBK 1012/3	Telecommunications Premises Distribution Planning, Design and Estimating
Technical Manuals (TM)	
TM 5-811-3	Electrical Design: Lightning and Static Electricity Protection
Unified Facilities Criteria (UFC)	
UFC 1-200-01	General Building Requirements, With Change 1
UFC 3-520-01	Interior Electrical Systems
UFC 3-530-01	Interior and Exterior Lighting Systems and Controls, With Change 3
UFC 3-550-01	Exterior Electric Power Distribution, With Change 1
UFC 3-600-01	Fire Protection Engineering for Facilities, With Change 1

UFC 4-021-01	Design and O&M: Mass Notification Systems, With Change 1
UFC 4-010-01	DOD Minimum Antiterrorism Standards for Buildings, With Change 1
UFC 4-211-01	Aircraft Maintenance Hangars, with Change 1
UFC 2-211-02	Aircraft Corrosion Control and Paint Facilities
Technical Instructions (TI)	
TI 800-01	Design Guide
International Code Council (ICC)	
IFC	International Fire Code
IBC	International Building Code
Telecommunication Industry Association (TIA) / Electronic Industries Alliance (EIA)	
TIA/EIA-568-B.1	Commercial Building Telecommunications Cabling Standard – Part 1: General Requirements
TIA/EIA-568-B.2	Commercial Building Telecommunications Cabling Standard – Part 2: Balanced Twisted pair Cabling Components
TIA/EIA-568-B.3	Optical Fiber Cabling components Standard
TIA/EIA-569-B	Commercial Building Standards for Telecommunications Pathways and Spaces
Building Industry Consulting Service International (BICSI)	
	Edition Telecommunications Distribution Methods Manual (TDMM)
United States Army Information Systems Engineering Command	
TG I3A	Technical Guide (TG) for Installation Information Infrastructure Architecture
United States Air Force, Engineering Technical Letter (ETL)	
ETL 13-4 (Change 1)	Standby Generator Design, Maintenance, and Testing Criteria
EC-385-1-223	Engineering Circular (EC) Interim Guidelines for Arc Flash Hazard Protection
ER 1110-345-700	Engineering Regulations (ER) Design Analysis, Chapter 1
ETL 1110-3-403	Electrical Power Systems for Non-Linear Loads

14.2.1 Other Publications and Code Compliance

In addition to the codes and standards listed above, all electrical work shall comply with the applicable requirements of the latest edition of the standards of the National Electrical Manufacturer's Association (NEMA); Insulated Power Cable Engineer's Association (IPCEA); and all applicable federal, state, city, and local codes, regulations, ordinances, publications, and manuals. All new manufacturer's equipment shall be listed by the Underwriter's Laboratory (UL) or a simpler testing laboratory acceptable to Eglin. When codes conflict, the more stringent shall govern.

14.2.2 Guide Specifications

Specifications are updated on a regular basis. Instruction for retrieving UFGS Specifications are provided in chapter 2, SPECIFICATIONS.

14.3 PROJECT DEFINITION (10-15%)

The Project Definition narrative shall include the requirements stated below and shall include all data and any calculations if required to support design decisions and estimates at this stage of design. The analysis shall incorporate specific criteria furnished and conference minutes for all systems considered. The analysis shall include the following:

14.3.1 Exterior Electrical Distribution System Design Analysis Narrative

- (a) Make a statement, with documentation, that the primary supply is adequate to support the added load. If the primary source is inadequate, state measures proposed to correct the deficiency in the design.
- (b) Provide a brief description of the electrical characteristics of the power supply from the service point to the main service equipment (voltage, phase, number, and size of conductors).
- (c) Provide brief description of the standards of design, such as physical characteristics of overhead and/or underground circuits. If underground, state the basis for the selection. Reference applicable conclusions and/or calculations (if necessary). State short circuit current available at the project site and state the source of this data.
- (d) Provide brief description of conductor type(s), such as copper or aluminum, and a justification for the choice made.
- (e) A statement shall be included describing all exterior lighting, with handicapped features if required.
- (f) List Unified Facilities Guide Specifications that will be used. The designer shall obtain the appropriate guide specifications and use them for design guidance.
- (g) Include a statement that no brand names or proprietary items will be used in the final plans and specifications.

14.3.2 Interior Electrical System Design Analysis Narrative

- (a) Provide a brief description of the electrical (voltage, phase, and number of wires) for

electrical system(s). Justification for the types of systems proposed (Economical or Special Condition).

- (b) Provide brief description of the lighting system(s) to be used for major areas.
- (c) State type of wiring system, such as rigid or intermediate conduit, electrical metallic tubing, nonmetallic sheathed cable, etc. that will be used.
- (d) Provide a paragraph describing special items of design, such as equipment, handicapped and seismic requirements, etc.; include description and location.
- (e) Clearly define and completely indicate all hazardous areas with the applicable class, group, division, and suitable operating temperature as defined in the National Electric Code. Do not attempt to “design around” the hazardous areas in lieu of designating the areas. State source of criteria, such as Safety Officer or other recognized official. Include documentation of the source of criteria.
- (f) Indicate if a lightning protection system will be required; if none, so state. (Reference TM 5-811-3 and NFPA 780).
- (g) Provide brief description of the grounding systems to be installed. If a counterpoise, grid, electromagnetic interference (EMI) shielding requirements, etc. is to be utilized, state standards to be used.
- (h) List UFGS that will be used. The designer shall obtain the appropriate guide specifications and use them for design guidance.
- (i) Include a statement that no brand names or proprietary items will be used in the final plans and specifications.

14.3.3 Exterior Electronic System Design Analysis Narrative

- (a) Provide a statement describing the extent of any exterior work such as telephone lines, duct banks, etc. outside of 5 feet from the building line. Provide a brief description of the standards of design.
- (b) List Unified Facilities Guide Specifications (UFGS) that will be used. The designer shall obtain the appropriate guide specifications and use them for design guidance.

14.3.4 Interior Electronic Systems Design Narrative

- (a) Where additions or alterations to existing systems are to be made, verify that the systems are expandable and can accommodate the additions or alterations. Provide a description of all proposed additions and alterations to each system.
- (b) Provide a descriptive narrative of all electronic systems that are required for the project. A list of possible electronic components and/or systems that may be required on a given project are as follows:
 - (1) Telecommunications/Data Systems
 - (2) Fire Detection and Alarm System

- (3) Special Grounding Systems
- (4) Public Address Systems
- (5) Security Systems
- (6) Mass Notification Systems
- (7) Access Control Systems (ACS)
- (8) Intrusion Detection Systems (IDS)
- (c) Define any hazardous areas (as defined in the National Electrical Code) and indicate the type of equipment proposed for use in such areas.
- (d) List Unified Facilities Guide Specifications (UFGS) that will be used. The designer shall obtain the appropriate guide specifications and use them for design guidance.

14.4 CONCEPT DESIGN (30-35%)

The Concept Design Analysis shall include the requirements stated below and shall include all data and calculations to support design decisions and estimates at this stage of design. The analysis shall incorporate specific criteria furnished and conference minutes for all systems considered. The analysis shall include the following:

14.4.1 Exterior Electrical Distribution System Design Analysis Narrative

- (a) Make a statement, with documentation, that the primary supply is adequate to support the added load. If the primary source is inadequate, state measures proposed to correct the deficiency in the design. Reference photographs of existing substations, pole line structures, or other exterior components. The photographs shall be included in the design analysis of all affected equipment and structures.
- (b) Provide the electrical characteristics of the power supply from the service point to the main service equipment (voltage, phase, number, and size of conductors).
- (c) Indicate type, number, kVA capacity and impedance of transformer installation proposed and state method of sizing. State primary and secondary connections of transformers (i.e. 12470 to 480Y/277 volts, Delta-wye) in accordance with ANSI C57.10.00.
- (d) State type of conductor, such as copper or aluminum, and where proposed to use and a justification for the choice made.
- (e) A statement shall be included describing the standards of design, such as primary and secondary voltage drop, and physical characteristics of overhead or underground circuits. If underground, state the basis for the selection. Reference applicable conclusions and/or calculations. State short circuit current available at project site and state the source of this data.

- (f) A statement shall be included describing all exterior lighting, with handicapped features if required. IES point-to-point calculation shall be submitted to support the selection for the aforementioned lighting system.
- (g) Include a statement that no brand names or proprietary items will be used in the final plans and specifications.
- (h) List Unified Facilities Guide Specifications that will be used. The designer shall obtain the appropriate guide specifications and use them for design guidance.
- (i) Provide Temporary data loggers on existing interior power panels for at least 30 days to document existing use and capacity.

14.4.2

Interior Electrical System Design Analysis Narrative

- (a) Indicate electrical Characteristics (voltage, phase, and number of wires) for electrical system(s). Justification for the types of systems proposed (Economical or Special Condition).
- (b) Provide a brief description of the lighting system(s) to be used for major areas and referencing calculations. Also include tabulation, showing the following:
 - (1) Room, name, and number.
 - (2) Lighting intensity for each room. (State the design basis such as illumination Engineering Society (IES), Definitive drawings, etc.)
 - (3) Type of fixture, either by Standard Drawing Number or, if not applicable, include three (3) manufacturer's catalog cut sheets of fixture type.
- (c) State type of wiring system, such as rigid or intermediate conduit, electrical metallic tubing, nonmetallic sheathed cable, etc. that will be used.
- (d) Provide a paragraph describing special items of design, such as equipment, receptacles, handicapped and seismic requirements, etc.; include description and location. Reference pertinent NEMA or any recognized standards to identify type receptacles selected.
- (e) Clearly define and completely indicate all hazardous areas with the applicable class, group, division, and suitable operating temperature as defined in the National Electric Code. Do not attempt to "design around" the hazardous areas in lieu of designating the areas. State source of criteria, such as Safety Officer or other recognized official. Include documentation of the source of criteria.
- (f) Describe basic characteristics of panelboards, protective devices, switchgear, motor control centers or other major equipment to be provided. Short circuit and voltage drop calculations must be included to the service. Indicate equipment interrupting rating and short circuit withstand current, and include the source of this information. Evidence shall be included to support that the equipment is manufactured, or can be manufactured, and supplied by at least three reliable manufacturers and that the space is adequate for the equipment having the greatest dimensions.

- (g) Describe electrical metering equipment to be provided.
- (h) Describe lightning protection system; if none, so state. (Reference TM 5-811-3 and NFPA 780).
- (i) Describe grounding system to be installed. If a counterpoise, grid, EMI shielding requirements, etc. is to be used, state standards to be used in design calculations.
- (j) Provide a firm statement that no brand names or proprietary items will be used in final plans and specifications.
- (k) Provide a statement identifying compliance with AT/FP requirements. See Chapter 18, ANTI-TERRORISM / FORCE PROTECTION for specifics.
- (l) Provide a statement that Arc Flash Hazard analysis, calculations, labels, and other information shall be provided.
- (m) List UFGS that will be used. The designer shall obtain the appropriate guide specifications and use them for design guidance.

14.4.3 Exterior Electronic System Design Analysis Narrative

- (a) Provide a statement describing the extent of any exterior work such as telephone lines, duct banks, etc. outside of 5 feet from the building line. Provide a brief description of the standards of design.
- (b) List Unified Facilities Guide Specifications (UFGS) that will be used. The designer shall obtain the appropriate guide specifications and use them for design guidance.

14.4.4 Interior Electronic Systems Design Narrative

- (a) Where additions or alterations to existing systems are to be made, verify that the systems are serviceable, expandable, and can accommodate the additions or alterations. Provide a description of all proposed additions and alterations to each system.
- (b) Provide a descriptive narrative of all electronic systems that are required for the project. A list of possible electronic components and/or systems that may be required on a given project are as follows:
 - (1) Telecommunications/Data Systems
 - (2) Fire Detection and Alarm System
 - (3) Special Grounding Systems
 - (4) Public Address Systems
 - (5) Security Systems
 - (6) Mass Notification Systems

(7) Access Control Systems (ACS)

(8) Intrusion Detection Systems (IDS)

- (c) Communications layout information shall be furnished from the users on “marked-up” 30% - 35% drawings.
- (d) Clearly define and completely indicate all hazardous classified locations with the applicable class, group, division, zone, and suitable operating temperature as defined in the National Electrical Code. Do not attempt to “design around” the hazardous areas in lieu of designating the areas. State source of criteria, such as Safety Officer or other recognized official. Include documentation of the source of the criteria.
- (e) List specification sections that will be used.

14.4.5 Drawings (30-35%)

14.4.5.1 Exterior Electrical

- (a) Existing and new electrical primary lines both overhead and underground shall be properly identified.
- (b) Show removals and relocations, if any. If extensive, provide separate drawings.
- (c) Indicate electrical characteristics of all items shown; include voltage, phase, conductor size, and kVA.
- (d) Show new construction and location of transformers.
- (e) Indicate the secondary service to the facility and whether it is overhead or underground.
- (f) Show guy leads and guy strengths on the plans. Guying calculations shall be submitted verifying the guying design shown.

14.4.5.2 Interior Electrical

- (a) Show typical room lighting and receptacle layouts on floor plan.
- (b) Show the service and main electrical service equipment and size of same.
- (c) Show the location of all major pieces of electrical equipment, including panelboards.
- (d) Show the proposed riser diagram. Sizes of all conduit, wires, cables, panels, etc. need not be included, except for the main service feeder. Where the electrical configuration cannot be adequately explained on a power riser diagram, a complete one-line diagram may be provided.
- (e) Provide samples of panelboards, switchboard, motor control and fixture schedules.
- (f) Clearly define and completely indicate all hazardous areas with the applicable class,

group, division, and suitable operating temperatures as defined in the National Electric Code. Do not attempt to “design around” the hazardous areas in lieu of designating the areas. State source of criteria, such as Safety Officer or other recognized official. Include documentation of the source of the criteria

14.4.5.3 Exterior Electronic Systems

- (a) Exterior work to be shown on electrical site plan or separate Electronic systems site plan.
 - (1) Existing and new communications service lines, both overhead and underground, shall be properly identified.
 - (2) Show removals and relocations, if any.

14.4.5.4 Interior Electronic Systems

- (a) Show the location of all electronic system panels, etc. on floor plans.
- (b) Show the proposed riser diagrams for all systems. Sizes of conduit, wires, cables, panels, etc. need not be included at the 30% - 35% design.
- (c) Provide a complete symbol legend for all devices or equipment shown on the plans.
- (d) It may be necessary for the designer to provide a recommended layout for telephone, LAN, mass notification and cable television (CATV) on floor plans.

14.5 INTERIM DESIGN (50% - 60%)

14.5.1 Design Analysis

This stage of design analysis shall be an entirely updated analysis (not amendments to concept submittal) to permit verification that the design complies with the criteria furnished and the approved Concept Design. Short circuit and voltage drop calculations shall be included to all panelboards.

14.5.1.1 Exterior Electrical Distribution System Design Analysis Narrative

- (a) Make a statement, with documentation, that the primary supply is adequate to support the added load. If the primary source is inadequate, state measures proposed to correct the deficiency in the design. Reference photographs of existing substations, pole line structures, or other exterior components. The photographs shall be included in the design analysis of all affected equipment and structures. Properly label all photographs indicating pole location, pole designation, and view orientation of picture.
- (b) Provide the electrical characteristics of the power supply from the service point to the main service equipment (voltage, phase, number, and size of conductors).
- (c) Indicate type, number, kVA capacity and impedance of transformer installation proposed. State primary and secondary connections of transformers (i.e. 12470 to 480Y/277 volts, Delta-wye) in accordance with ANSI C57.10.00.

- (d) State type of conductor, such as copper or aluminum, and where proposed to use and a justification for the choice made.
- (e) A statement shall be included describing the standards of design, such as primary and secondary voltage drop, and physical characteristics of overhead or underground circuits. If underground, state the basis for the selection. Reference applicable conclusions and/or calculations. State short circuit current available at project site and state the source of this data.
- (f) A statement shall be included describing all exterior lighting, with handicapped features if required. Types of fixtures, pole heights, and proposed intensities are to be included. IES point-to-point calculation shall be submitted to support the selection for the aforementioned lighting system.
- (g) Include a statement that no brand names or proprietary items will be used in the final plans and specifications.
- (h) List Unified Facilities Guide Specifications that will be used.

14.5.1.2

Interior Electrical System Design Analysis Narrative

- (a) Indicate electrical Characteristics (voltage, phase, and number of wires) for electrical system(s). Justification for the types of systems proposed (Economical or Special Condition). A life cycle analysis is required on 120/208 volt system above 300kVA.
- (b) Provide a description of the lighting system(s) to be used for all areas, referencing calculations and economic analysis. Also include tabulation, showing the following:
 - (1) Room, name, and number.
 - (2) Lighting intensity for each room. (State the design basis such as illumination Engineering Society (IES), Definitive drawings, etc.)
 - (3) Type of fixture, either by Standard Drawing Number or, if not applicable, include three (3) manufacturer's catalog cut sheets of each fixture type.
 - (4) Lighting with emergency ballast testing
- (c) State type of wiring system, such as rigid or intermediate conduit, electrical metallic tubing, nonmetallic sheathed cable, etc. and location of proposed use.
- (d) Provide a paragraph describing special items of design, such as equipment, receptacles, handicapped and seismic requirements, etc.; include description and location. Reference pertinent NEMA or any recognized standards to identify type receptacles selected.
- (e) Clearly define and completely indicate all hazardous areas with the applicable class, group, division, and suitable operating temperature as defined in the National Electric Code. Do not attempt to "design around" the hazardous areas in lieu of designating the areas. State source of criteria, such as Safety Officer or other recognized official. Include documentation of the source of criteria. Ensure that all devices installed in

hazardous classified locations are shown and/or specified as suitable for the location in which they are installed.

- (f) Describe basic characteristics of panelboards, protective devices, switchgear, motor control centers or other major equipment to be provided. Short circuit and voltage drop calculations must be included to the service. Indicate equipment interrupting rating and short circuit withstand current, and include the source of this information. Evidence shall be included to support that the equipment is manufactured, or can be manufactured, and supplied by at least three reliable manufacturers and that the space is adequate for the equipment having the greatest dimensions.
- (g) Describe electrical metering equipment to be provided. If the facility has a utility monitor and control systems (UMCS) energy management and control system (EMCS), address method to provide signals to master station.
- (h) Describe lightning protection system; if none, so state. (Reference TM 5-811-3 and NFPA 780).
- (i) Describe grounding system to be installed. If a counterpoise, grid, EMI shielding requirements, etc. is to be used, state standards to be used in design calculations.
- (j) Provide a firm statement that no brand names or proprietary items will be used in final plans and specifications.
- (k) Provide a statement identifying compliance with AT/FP requirements. See Chapter 18, ANTI-TERRORISM / FORCE PROTECTION for specifics.
- (l) Include a statement certifying the designer has implemented to 30% - 35% annotated comments.
- (m) List UFGS that will be used. The designer shall obtain the appropriate guide specifications and use them for design guidance.

14.5.2 Drawings (50% - 60%)

14.5.2.1 General

- (a) All removals must be shown. If removals are extensive, separate demolition plans are required. The designer shall display the information in such a manner that it would not be necessary to visit the site to prepare a bid.
- (b) A complete legend shall be provided for all devices and equipment shown on the plans. Mounting heights shall be included as applicable.

14.5.2.2 Exterior Electrical

All exterior electrical shall be completed in plan with poles and other pertinent components detailed. Details shall include transformer's location, type of construction, kVA, impedance, voltage, phase, and type, size, and number of conductors. If manholes and/or handholes are required for underground, utilize typical manhole from UFC 3-550-03FA. Manholes and/or handholes shall be detailed on final drawings.

14.5.2.3 Interior Electrical

- (a) Power riser or one-line diagram shall be essentially complete except for finalization of conduit and wire sizes.
- (b) Panelboards, motor control centers, switchgear equipment and all utilization equipment shall be located with schedules and physical layout arrangement completed. Provide front elevations for freestanding equipment.
- (c) Branch circuits, lighting fixtures with switches, receptacles, and motors shall be shown with number of conductors indicated.
- (d) A completed fixture schedule shall be included on the drawings.
- (e) Before submittal, drawings shall be thoroughly checked by the designer for discrepancies and conflicts. Particularly as related between disciplines and various systems above dropped ceilings.

14.5.2.4 Electronic Systems

- (a) All exterior plans shall be completed.
- (b) Thoroughly check for discrepancies and conflicts, particularly between disciplines.
- (c) All removals must be shown. If removals are extensive, separate demolition plans are required.
- (d) Provide riser diagrams for fire detection and alarm system, intrusion detection system, public address system, telephone system, mass notification system, etc. Risers should show the location of the various components and interconnections with other systems such as HVAC panel connection to fire alarm panels, etc.
- (e) Show location of all devices (fire alarm, mass notification, communications, etc.) and equipment for electronic systems on the floor plans. Show location of devices to be interconnected; e.g. show duct-mounted smoke detectors, hood fire-suppression system contacts for fire alarm system input, etc. Location of all devices shall conform to NFPA 72 and UFC 3-600-01, ADAAG (ADA Accessibility Guideline) and/or UFAS.
- (f) Provide details of telephone outlets, telephone backboard arrangement, and other items required by criteria or comment.
- (g) Provide date for special ground system.

14.5.3 Specifications

Provide redlined, marked-up specifications in accordance with Chapter 2, SPECIFICATIONS.

14.5.4 Additional Criteria

Any additional criteria, deviations concerning criteria, questions or problems should be listed.

14.6 FINAL DESIGN (UNREVIEWED 100%)

The comments generated during the Concept Review shall be answered or incorporated into the Final Design analysis (not amended sheets) and drawings before they are submitted as Final.

14.6.1 Design Analysis

- (a) The Final Design analysis is an extension of the approved Concept Design analysis and supports and verifies that the design complies with the requirements of the project.
- (b) A coordination analysis of the electrical system shall be provided as stated herein below. This requirement depends on the complexity of the project. It shall not be provided for projects nonadjustable protective devices for which coordination is not possible (e.g. standard molded case breakers). Projects that are served by a transformer 750 kVA or less do not require a study. All other systems shall have a coordination study provided.
- (c) An arc fault hazard analysis shall be performed for all buildings. The analysis shall show arc fault energy, arc fault boundaries, and PPE requirements in both tabular form and on a one-line diagram. Arc flash labels shall also be provided for, but not limited to, all transformers, switchgear, switchboards, motor control centers, panelboards, disconnect switches and other locations where exposure to energized parts is possible.

14.6.2 Drawings

The final drawings are an extension of the approved 50%-60% drawings and shall incorporate the 50%- 60% comments.

- (a) All details for final package shall be in the drawings (pole details, fixture details, etc). Congested areas where there can be interference with various electrical systems, cable trays, piping, ducts, etc. shall be thoroughly detailed by expanded scale drawings.
- (b) Thoroughly check the drawings for discrepancies, for compatibility between drawings and specifications, and for compatibility between disciplines. Check the following as a minimum, but do not limit checking to these items:
 - (1) Verify compatibility between electrical, electronic systems, and other disciplines (equipment locations, reflected ceiling plans, motor voltage and across the line as reduced voltage starters and horsepower, NEMA enclosures, plans and specifications for systems furnished in other specification sections, etc.), to ascertain that there are no conflicts on the drawings.
 - (2) Panelboards, motor control center, switchboard and switchgear schedules, home runs, and floor plans.
 - (3) Power riser or one-line diagram configuration agrees with floor plans.
 - (4) Legend and/or symbols complete and compatible with drawings.

- (5) Fixture types indicated on the drawings agree with fixture schedule.
- (6) Assures design complies with design analysis and criteria.
- (7) Adequacy of details and control diagrams.
- (8) Proper and practical circuitry with number of conductors and conduit sizes indicated correctly.
- (9) Clearly define and completely indicate all hazardous areas with the applicable class, group, division, and suitable operating temperature as defined in the National Electric Code. Do not attempt to “design around” the hazardous areas in lieu of designating the areas. State source of criteria, such as Safety Officer or other recognized official. Include documentation of the source of criteria. Ensure that all devices installed in hazardous classified locations are shown and/or specified as suitable for the location in which they are installed.
- (10) Ensure that all electronic systems are provided with power.
- (11) Ensure that the proper receptacle type(s) are provided for the specific special purpose equipment that will be used in the facility. Obtain equipment list and requirements from user.

14.6.3 Specifications

Provide specifications if not provided at the Interim submittal. Provide final edited specifications if an Interim Submittal was prepared in accordance with Chapter 2, SPECIFICATIONS.

- (a) Read thoroughly and comply with the instructions in each set of guide specifications, including notes to specification writer. It is highly recommended to use SpecsIntact specification writing system to prepare project specifications.
- (b) Do not specify proprietary items unless specifically directed otherwise.
- (c) The specifications shall require the contractor to provide a system short circuit study and coordination curves for the equipment to be furnished. The study and curves shall be approved prior to approval of shop drawings for the equipment. The study shall not be required for projects with nonadjustable protective devices for which coordination is not possible (e.g. standard molded case breakers). Projects that are served by a transformer 750 kVA or less do not require a study. Certain facilities where the loss or power would be critical shall also require the study.
- (d) If the design is predominantly exterior overhead or underground with a small amount of information required that is contained in the interior electrical specifications, the design specifications may include excerpts from the interior specifications in either the overhead or underground specifications and the title changed to “Electrical”. This procedure must have prior written approval.

14.7 READY-TO-ADVERTISE (REVIEWED 100%)

- (a) The comments generated during the Final Review shall be answered or incorporated

into the completed design analysis (not amended sheets), specifications, and drawings before they are submitted as “Ready-To-Advertise”.

- (b) The analysis shall be complete and shall support the requirements of the project.
- (c) The drawings and specifications shall be complete and thoroughly checked. Where additions to existing electronics systems are made, the designer shall have verified that the existing system is expandable and can accommodate the additions. This verification shall include an on-site survey of the system and contacts with the manufacturer to ensure that the expansion modules, etc. are available. Information on manufacturer, model number, etc. of the existing electronic equipment shall be included on the plans and specifications. This is typical of expansions made to existing fire alarm and public address systems.

14.8 TECHNICAL REQUIREMENTS

14.8.1 Metering and temporary power shall be as required per UFC 3-520-01.

14.8.2 Salvageable Material

The salvageable material resulting from a demolition design and not reincorporated in the design remains the property of the government. The debris shall be disposed of as directed by the COR. Typical removal paragraphs are listed below.

14.8.2.1 Removals

Where indicated, existing equipment and material shall be removed and shall remain the property of the government. Salvageable equipment and materials shall be delivered as directed by the COR for storage on the premises. Materials and debris considered unsalvageable by the COR shall be disposed of as directed.

14.8.2.2 Reuse of Removed Materials

Removed materials except for poles shall be reused if they are in good condition and they meet the requirements of this section of the specifications. Removed wooden poles shall not be reinstalled. (Removed materials not incorporated in the new work shall be delivered for storage and/or disposal as directed by the COR).

14.8.3 Special Items

The following items shall be included in each submittal, where applicable.

- (a) Unified Facility Guide Specifications must be used in preparing contract specifications for diesel-electric generators. Unless application requires otherwise, provide brushless type generators.
- (b) Egress lighting must comply with life safety code NFPA 101. In the concept and design analysis, document the chapters and paragraphs for which the design is based upon.
- (c) Facilities requiring design for the handicapped shall comply with the consolidated ADA-ABA guidelines.

- (d) Distribution systems and equipment outside of buildings are to be adequately anchored, braced, or guyed to withstand hurricane winds. Details with supporting design analysis and specifications will be provided to verify conformance with the applicable codes and regulations for the specific project location.
- (e) Provide both green grounding conductors and driven electrodes for exterior lighting poles.
- (f) Seismic design, when required, shall be in accordance with UFC 1-200-01.
- (g) Dedicated electrical space shall be provided around and above panelboards, switchboards, transformers, transfer switches, motor control centers and similar major items of electrical equipment. This space shall be defined in accordance with UFC 3-520-01.
- (h) Fire Resistant Ceilings. When a false ceiling is used as the fire-resistant ceiling, then the lighting fixtures shall be installed in accordance with Underwriters Laboratories Fire Resistance Directory. The lighting fixtures specified shall be classified for fire resistance and shall be so noted in the lighting fixture schedule.
- (i) Electrically driven fire pumps. The designer shall insure that the requirements of NFPA 20 are met in all designs that include fire pumps. A letter from Eglin confirming reliability of the utility service in accordance with UFC 3-600-01 and calculations that substantiate the starting voltage drop requirements must be submitted by the designer.
- (j) Interior Lighting Systems. The lighting design shall incorporate the latest techniques of energy savings applied to lighting systems.

14.8.4 Design Criteria for Non-linear Loads

- (a) The design of electrical distribution shall consider the effects that harmonics from non-linear loads can produce on the system. Harmonics from non-linear loads can affect the sizes of the neutral conductor, panelboards, phase conductors and emergency generators. Design for facilities with non-linear loads shall be in accordance with ETL 1110-3-403.
- (b) “K” rated transformers shall be used where the associated panelboards are feeding a large quantity of non-linear loads. Special attention shall be given to the harmonics produced by variable speed and variable frequency drive units for control of HVAC equipment.

Chapter 15 - Corrosion Control and Cathodic Protection Systems

15.1 GENERAL

15.1.1 Scope

This chapter gives general guidelines for the preparation of drawings, specifications, and design analysis as related to corrosion control and cathodic protection systems. A cathodic protection (CP) system shall be provided where applicable; project design and construction without considering CP are not acceptable. CP is a functional requirement for virtually all projects involving new aboveground water tanks, direct buried or submerged metallic structures (including metallic components of nonmetallic pipelines), or the repair or replacement of similar existing structures. New buildings requiring fire sprinkler systems are one example of projects requiring CP. Although new fire lines supplying new buildings may be constructed of non-metallic materials such as polyvinyl chloride (PVC), fire lines will contain some or all the following buried metallic components: post indicator valves (PIVs), fire hydrants, pressurized metallic piping under floor slabs, change of direction devices, valves, and other buried metallic components. Buried metallic components of fire lines require cathodic protection under this chapter. Specific submittal requirements in this chapter supplement the requirements of Chapter 1 GENERAL INSTRUCTIONS.

15.1.2 Design Submittals

- (a) The following submittal guidelines have been developed for the most common projects such as cathodic protection design for the protection of new buried metallic piping to building(s) and utility facilities that might be constructed in support of those new buildings such as water tanks, fuel tanks, sewage lift stations, etc. Projects, which require extensive, unusual, or complicated cathodic protection work, will have special submittal requirements developed for that project.
- (b) The requirements shall be defined, developed, and agreed upon at the pre-design conference and will become part of the contract.
- (c) Design submittals will be reviewed for general compliance with criteria. Some detailed checks will be made. The designer should accomplish complete and independent checking of the design. The designer is fully responsible for the design. The design should be complete and accurate. It should be thoroughly checked for errors, conflicts (both within and between disciplines), and proprietary requirements. No proprietary restrictions may be included in the contract unless specifically authorized.

15.2 APPLICABLE PUBLICATIONS

National Fire Protection Association (NFPA)

NFPA 70

National Electrical Code

National Association of Corrosion Engineers (NACE)

NACE RP0169	Control of External Corrosion on Underground or Submerged Metallic Piping Systems
NACE RP0177	Mitigation of Alternating Current and Lightning Effects on Metallic Piping Systems
NACE RP0187	Design Considerations for Corrosion Control of Reinforcing Steel in Concrete
NACE RP0188	Discontinuity (Holiday) Testing of Protective Coatings
NACE RP0193	External Cathodic Protection of On-Grade Metallic Storage Tank Bottoms
NACE RP0274	High-Voltage Electrical Inspection of Pipeline Coatings
NACE RP0285	Corrosion Control of Underground Storage Tank Systems by Cathodic Protection
NACE RP0286	The Electrical Isolation of Cathodically Protected Pipelines
NACE RP0388	Impressed Current Cathodic Protection of Internal Submerged Surfaces of Carbon Steel Water Storage Tanks
NACE RP0572	Design, Installation, Operation, and Maintenance of Impressed Current Deep Groundbeds

Unified Facilities Criteria (UFC)

UFC 3-570-01	Cathodic Protection
UFC 3-570-06	Operation and Maintenance: Cathodic Protection Systems

Technical Instruction (TI)

TI 800-01	Design Criteria
-----------	-----------------

Air Force Instruction (AFI)

AFI 32-1054	Corrosion Control
-------------	-------------------

Engineering Regulation (ER)

ER 1110-345-700	Appendix B, Design Analyses
-----------------	-----------------------------

Engineering Technical Letter (ETL)

ETL 1110-3-474	Engineering and Design Cathodic Protection
----------------	--

Code of Federal Regulations (CFR)

- CFR 40 Part 280 Technical Standards and Corrective Action Requirements for Owners and Operators of Underground Fuel Storage Tanks (UST)
- CFR 49 Part 192 Transportation of Natural and other Gas by Pipeline: Minimum Federal Safety Standards
- CFR 49 Part 195 Transportation of Hazardous Liquids by Pipeline

Other Publications and Code Compliance:

In addition to the codes and standards listed above, all electrical work associated with cathodic protection work shall comply with the applicable requirements of the latest edition of the standards of the National Electrical Manufacturer's Association (NEMA); and all applicable federal, state, city, and local codes, regulations, ordinances, publications, and manuals. The Underwriter's Laboratory (UL) or a similar testing laboratory acceptable to the U. S. Army Corps of Engineers (USACE) shall list all new manufactured equipment. When codes conflict, the more stringent shall govern.

Unified Facility Guide Specifications (UFGS)

Specifications are updated on a regular basis. Instructions on retrieving UFGS specifications are covered in Chapter 2 SPECIFICATIONS. For cathodic protection design, the following guide specifications shall be utilized, as applicable:

- UFGS 26 42 14.00 10 Cathodic Protection System (Sacrificial Anode)
- UFGS 26 42 13.00 10 Cathodic Protection System (Steel Water Tanks)
- UFGS 26 42 15.00 10 Cathodic Protection System (Impressed Current)

15.3 PROJECT DEFINITION (10%-15%)

Project Definition shall include the requirements stated below and shall include all data and calculations to support design decisions and estimates at this stage of design. The analysis shall incorporate specific criteria furnished and conference minutes of all systems considered. The analysis shall include the following:

15.3.1 Design Analysis

- (a) Provide the name of the licensed Corrosion Engineer, certified NACE Cathodic Protection Specialist, or certified NACE Corrosion Specialist.
- (b) New or supplemental Cathodic Protection (CP) shall be compatible to the existing CP systems (if operational) and other adjacent structures or components. It is the responsibility of the "Corrosion Expert", as defined in this chapter, to verify, during the pre- design cathodic protection survey, the operability of existing cathodic protection systems located adjacent to or in the vicinity of the new metallic structures requiring cathodic protection. All variables that may compromise the operation of the new cathodic protection system, such as interference and grounding to existing structures, etc., must be considered in the design. The design shall require remedial actions that will mitigate all interference, grounding, and other undesirable effects to

enable the new CP system to afford the required potentials. New systems will be compatible with installation wide systems to allow ease of repair and maintenance. New metallic pipelines or other metallic structures which are to be connected to existing metallic pipelines or other existing structures shall be electrically isolated by the installation of isolation flanges between the new and old metallic structures, regardless if the existing metallic structure is cathodically protected or not. That is, new cathodic protection systems must be independent and isolated from existing cathodic protection systems and designed such that the new CP system provides the specified protective potentials to the new metallic structure. Any variation from the installation of isolation flanges between new and old pipelines, such as expansions of existing cathodic protection systems to accommodate new pipe extensions, must be submitted to and approved by Eglin Engineering. Expansions of existing CP systems to new pipelines or other metallic structures requiring cathodic protection must be supported by CP field survey data, including potential surveys of existing pipelines under cathodic protection, existing isolation flange tests, existing coating integrity tests, etc. All these tests, as well as other tests that might be necessary to support the design, must be conducted by the "Corrosion Expert" and results and procedures included in the Design Analysis. Where additions or alterations to existing CP systems are to be recommended, verification and substantiation that the systems are operational, expandable, and can accommodate the additions or alterations are mandatory. Provide a description of all proposed additions and alterations to each system. Information on manufacturer, model number, etc., of the existing cathodic protection equipment shall be included in the plans and specifications.

- (c) Provide a descriptive narrative of all cathodic protection systems and other corrosion control measures that are required for project. The narrative shall describe the extent of the corrosion control and cathodic protection work both inside and outside of the 5-foot line from the building perimeter. Provide brief description of the standards of design. Any project that includes buried or submerged metallic surfaces must be evaluated for corrosion control requirements in accordance with this chapter and with the guidance of all other referenced documents included in this chapter.
- (d) Provide the following for cathodic protection systems:
 - (1) Clearly define areas of structures or components in soil or water to be protected.
 - (2) Type system recommended (i.e., sacrificial or impressed current), comparison of systems, and cost estimate showing all equipment alternatives.
- (e) Define any hazardous areas (as defined in the National Electrical Code) and indicate the type of any cathodic protection equipment proposed for use in such areas.
- (f) List the specifications that will be used.

15.4 CONCEPT DESIGN (30%-35%)

15.4.1 Design Analysis

The Concept Design analysis shall include the requirements stated below and shall include all data and calculations to support design decisions and estimates at this stage of design. The analysis shall incorporate specific criteria furnished and conference minutes of all systems considered. The analysis shall include the

following:

- (a) Provide the name of the licensed Corrosion Engineer, certified NACE Cathodic Protection Specialist, or certified NACE Corrosion Specialist.
- (b) New or supplemental CP shall be compatible to the existing CP systems (if operational) and other adjacent structures or components. It is the responsibility of the “Corrosion Expert”, as defined in this chapter, to verify, during the pre- design cathodic protection survey, the operability of existing cathodic protection systems located adjacent to or in the vicinity of the new metallic structures requiring cathodic protection. All variables that may compromise the operation of the new cathodic protection system, such as interference and grounding to existing structures, etc., must be considered in the design. The design shall require remedial actions that will mitigate all interference, grounding, and other undesirable effects to enable the new CP system to afford the required potentials. New systems will be compatible with installation wide systems to allow ease of repair and maintenance. New metallic pipelines or other metallic structures which are to be connected to existing metallic pipelines or other existing structures shall be electrically isolated by the installation of isolation flanges between the new and old metallic structures, regardless if the existing metallic structure is cathodically protected or not. That is, new cathodic protection systems must be independent and isolated from existing cathodic protection systems and designed such that the new CP system provides the specified protective potentials to the new metallic structure. Any variation from the installation of isolation flanges between new and old pipelines, such as expansions of existing cathodic protection systems to accommodate new pipe extensions, must be submitted to and approved by the Eglin AFB, Engineering Group specialist. Expansions of existing CP systems to new pipelines or other metallic structures requiring cathodic protection must be supported by CP field survey data, including potential surveys of existing pipelines under cathodic protection, existing isolation flange tests, existing coating integrity tests, etc. All these tests, as well as other tests that might be necessary to support the design, must be conducted by the “Corrosion Expert” and results and procedures included in the Design Analysis. Where additions or alterations to existing CP systems are to be recommended, verification and substantiation that the systems are operational, expandable, and can accommodate the additions or alterations are mandatory. Provide a description of all proposed additions and alterations to each system. Information on manufacturer, model number, etc., of the existing cathodic protection equipment shall be included in the plans and specifications.
- (c) Provide a descriptive narrative of all cathodic protection systems and other corrosion control measures that are required for project. The narrative shall describe the extent of the corrosion control and cathodic protection work both inside and outside of the 5-foot line from the building perimeter. Provide brief description of the standards of design. Any project that includes buried or submerged metallic surfaces must be evaluated for corrosion control requirements in accordance with this chapter and with the guidance of all other referenced documents included in this chapter.
- (d) Provide the following for cathodic protection systems:
 - (1) Clearly define areas of structures or components in soil or water to be protected.

- (2) Type system recommended (i.e., sacrificial or impressed current), comparison of systems, and cost estimate showing all equipment alternatives.
- (3) Calculations on all systems that are considered, showing all information and descriptions.
- (4) Estimate showing materials and cost.
- (e) Define any hazardous areas (as defined in the National Electrical Code) and indicate the type of any cathodic protection equipment proposed for use in such areas.
- (f) List the specifications that will be used.

15.4.2 Drawings

Cathodic Protection work to be shown on Utilities Site Plan or separate Cathodic Protection Systems Site Plan:

- (a) Identify any gas lines, water lines, fire protection lines, fuel lines, force main lines, and all other structures that are to be protected by the Cathodic Protection System as required by this chapter, as well as applicable laws and regulations.
- (b) Show removals and relocations, if any.

15.4.3 Removal or Demolition

A general narrative of the removal and/or demolition will be included.

15.4.4 Specifications

Provide a basic outline in accordance with Chapter 2 SPECIFICATIONS.

15.4.5 Additional Criteria/Information

Any additional criteria, deviations concerning criteria, questions or problems developed during the Concept Design phase will be listed.

15.5 INTERIM DESIGN (50%-65%)

In addition to the following items, the designer shall incorporate or answer all comments received during the Concept Design submittal review.

15.5.1 Design Analysis

This Interim Design Analysis shall be an entirely updated analysis (not amendments to concept submittal) to permit verification that the design complies with the criteria furnished and the approved Concept Design.

15.5.2 Drawings

15.5.2.1 General

- (a) All removals must be shown. If removals are extensive, separate demolition plans are required. The designer shall display the information in such a manner that it would

not be necessary to visit the site to prepare a bid.

- (b) A complete legend shall be provided for all devices and equipment shown on the plans. Mounting heights shall be included as applicable.

15.5.2.2 Cathodic Protection Systems

- (a) All plans should be completed.
- (b) Thoroughly check for discrepancies and conflicts, particularly between disciplines.
- (c) Cathodic protection system should be complete including analysis, narrative description of system, and drawings. The submittal shall include drawings showing all structures or components to be protected and all cathodic protection components in relation to the protected structure. This includes showing sacrificial and impressed current anodes, rectifiers, isolation (dielectric), bonding, and any other data needed to define the scope and area of the cathodic protection system.
- (d) Show location of all devices and equipment for cathodic protection system on the floor plans if any components, such as rectifiers, are to be mounted inside of the building. Show location of devices to be inter-connected. Include all CP rectifier circuits in electrical panel schedules.

15.5.3 Specifications

Provide redlined marked up specifications in accordance with Chapter 2, SPECIFICATIONS.

15.5.4 Additional Criteria

Any additional criteria, deviations concerning criteria, questions or problems should be listed.

15.6 FINAL DESIGN (UNREVIEWED 100%)

Comments generated during the Interim Design submittal review shall be incorporated or answered in the design analysis, specifications and drawing before they are submitted as "Final".

15.6.1 Design Analysis

This analysis is an extension of the approved 50%-65% design analysis and supports and verifies that the design complies with the requirements of the project.

15.6.2 Drawings

The final drawings are an extension of the approved 50%-60% drawings and shall incorporate the Concept Design submittal review comments.

- (a) All details for final package shall be on the drawings.
- (b) Thoroughly check the drawings for discrepancies, for compatibility between drawings and specifications, and for compatibility between disciplines. The Final Drawings should be in a Ready-to-Advertise state which should include, but not be limited to, the following items as applicable:

- (1) Verify compatibility between civil/site utilities, environmental, mechanical, electrical, CP systems, and other disciplines (equipment locations, NEMA enclosures, plans and specifications for systems furnished in other specification sections, etc.), to ascertain that there are no conflicts on the drawings relating to the installation of all new CP systems.
- (2) Panel board locations and home runs to rectifiers.
- (3) Terminal cabinet and test station locations.
- (4) Rectifier locations.
- (5) Legend and/or symbols complete and compatible with drawings.
- (6) Assure design complies with design analysis and criteria.
- (7) Adequacy of details and diagrams.
- (8) Proper and practical circuitry with type, quantity, and size of conductors; and the type, quantity and size of conduits indicated correctly.
- (9) Ensure that all hazardous areas are clearly defined where rectifiers and other electrical equipment are to be located.
- (10) Ensure that all cathodic protection rectifiers are provided with power.

15.6.3 Specifications

Provide specifications if not provided at the Interim submittal. Provide final edited specifications if an Interim submittal was prepared in accordance with Chapter 2, SPECIFICATIONS.

- (a) Do not specify proprietary items. See Chapter 2 Specifications.
- (b) Ascertain that major or special types of equipment are available commercially.

15.7 READY-TO-ADVERTISE (REVIEWED 100%)

- (a) The comments generated during the Final design submittal review shall be incorporated into the design analysis (not amended sheets), specifications, and drawings before they are submitted as Ready-to-Advertise.
- (b) The analysis shall be complete and shall support the requirements of the project.
- (c) The drawings and specifications shall be complete and thoroughly checked. Where additions to existing cathodic protection systems are made, the designer must follow the guidance included in previous submittals described in this chapter.

15.8 TECHNICAL REQUIREMENTS

15.8.1 Salvageable Material

The Designer shall clearly identify materials that are to be salvaged. Salvageable material resulting from demolition that is not reincorporated into the design shall remain the property of the U.S. Government. Salvageable equipment and materials shall be delivered to the Contracting Officer's representative for storage on the premises as directed.

15.8.1.1 Removals

All materials not identified to be salvaged or reused shall be disposed of by the Contractor either off Government property or as directed by the Installation.

15.8.1.2 Reuse of Existing Materials

Existing materials shall be reused if they are in good condition, and they meet the requirements of this section of the specifications.

15.8.2 Corrosion Control and Cathodic Protection

- (a) For all metal facilities located in the atmosphere, soil, or water electrolytes, corrosion control shall be provided. In all instances, cathodic protection, or approval to omit it, shall be provided for metals in soils or water. Coatings are normally provided as corrosion protection in the atmosphere. A cathodic protection system shall be provided where applicable; project design and construction without considering cathodic protection are not acceptable. As a minimum, cathodic protection and protective coatings shall both be provided for the following buried or submerged ferrous metallic structures, regardless of soil or water resistivity:

Natural gas and propane piping, including metallic components of nonmetallic lines

Liquid fuel piping

Oxygen piping

Bottom of on-grade fuel and water storage tanks

Interior of water tanks and elevated tank risers

Underground metal storage tanks, piping, and ancillary items

Metallic components of force mains

Metallic components of backflow preventors

Fire protection lines or water lines utilized for fire protection, including metallic components of non-metallic lines (i.e., PIVs, fire hydrants, change or direction devices, valves, metallic sections under building slab and elsewhere, etc.)

Steel, ductile iron, and cast-iron pressurized piping under floor (slab on grade) in soil

Underground heat distribution and chilled water piping in ferrous metallic

conduit

Oil/Water separators and all associated metallic fittings in contact with soil

Sewage lift stations (all metallic components in contact with soil or liquids)

Other structures with hazardous products as identified by the user of the facility

- (b) These are some of the systems and components requiring cathodic protection by technical instructions and other military criteria, regulations, and/or law but are not all-inclusive.
- (c) The results of an economic analysis and recommendations by a “corrosion expert” shall govern the application of CP and protective coatings on gravity sewer lines, regardless of soil resistivity, and for potable water lines in resistivities above 10000 ohm-centimeters (unless the CP is a requirement on the potable water line due to other reasons, such as pressurized steel piping under floor slab, as listed above).
- (d) The “Corrosion Expert” shall identify special areas of concern that could create a need for corrosion mitigation. For example, the installation of grounding systems could create special corrosion problems such as the introduction of dissimilar metal corrosion cells (i.e., copper ground rods interconnected to other metal piping, etc.). Resolution of these type of special problems must be incorporated into the cathodic protection design or some other part of the total corrosion mitigation plan.

15.8.2.1

Coating Requirements

- (a) In addition to cathodic protection requirements, a minimum coating thickness of 40 mils is required on all underground metal.
- (b) The only coating types that are allowed to be utilized on metallic components, structures, and pipelines that are cathodically protected are listed in the applicable cathodic protection specification section. These coating types shall have precedence over all other specification sections that may specify or allow other coating types for metallic components and structures that are to be cathodically protected.
- (c) Unbonded coatings, such as polyethylene encasement, shall not be allowed on pipelines or components requiring cathodic protection as defined in this chapter and in referenced documents and criteria. Additionally, the use of unbonded coatings such as loose polyethylene wraps are prohibited for all buried metallic components and pipelines installed for Air Force projects, regardless if cathodic protection is also applied or not.
- (d) Services of a NACE International certified Coating Inspector shall be ascertained. The NACE Certified Coating Inspector shall closely coordinate with the “Corrosion Expert” described herein to assure that the proper coating system is selected for application on the installed pipelines or other structures in order to provide a completely compatible and operable total corrosion control system consisting of both coatings and cathodic protection. The NACE Certified Coating Inspector shall assure, by personal observation and inspection that all surfaces are properly prepared and that only qualified coating contractors are utilized to properly apply all coatings.

The Coating Inspector shall assure that the use of unbonded coatings (such as PE encasement on ductile iron piping) is not allowed; the use of such unbonded coatings is strictly prohibited. The NACE Certified Coating Inspector shall perform a complete coating inspection of all applied coatings prior to backfilling, in accordance with the applicable NACE coating standards. The qualifications documentation of the coating inspector must be submitted to the government for approval.

15.8.2.2 Qualifications for Cathodic Protection Work

Cathodic protection field work (pre-design surveys), analysis, and design must be accomplished by or under direct supervision of a “corrosion expert.” “Corrosion expert” refers to a person, who by thorough knowledge of the physical sciences and the principles of engineering and mathematics, acquired by professional education and related experience, is qualified to engage in the practice of corrosion control of buried or submerged metallic surfaces. Such a person must be accredited or certified by NACE International [formerly the National Association of Corrosion Engineers (NACE)] as a NACE Accredited Corrosion Specialist or a NACE certified Cathodic Protection (CP) Specialist or be a registered professional engineer who has certification or licensing that includes education and experience in corrosion control of buried or submerged metallic piping and tank systems, if such certification or licensing includes 5 years’ experience in corrosion control on underground and/or submerged metallic surfaces of the type under this contract. The “corrosion expert’s” name and qualifications shall be certified prior to start of design. He must be available to answer questions relating to his work.

15.8.2.3 Description of Analysis Work

- (a) The “Corrosion Expert” is responsible for assuring that all necessary field data such as resistivity measurements, etc., is obtained for the cathodic protection design. He must assure that resistivity measurements are taken along the pipeline and/or other buried or submerged metallic structure that will be cathodically protected and in areas of proposed anode ground beds. The geotechnical engineer may conduct measurements in the necessary locations or areas as designated by the “Corrosion Expert” to provide the designer the data necessary to determine Interim size and type cathodic protection for structures to be protected. The resistivity, soil borings, and other soils data should be provided in the Foundation Report. The designer is required to obtain the necessary resistivity and other design data if the geotechnical engineer does not obtain this information in the appropriate locations.
- (b) The preliminary design submittal shall include economic justification for selection of type of cathodic protection system (sacrificial or impressed current), soil corrosiveness (resistivity, pH, etc.) data, current requirement test (if applicable), potential survey data (if applicable to existing structures), and all design calculations for cathodic protection in the basis of design.
- (c) The design shall provide sufficiently detailed calculations and one-line diagrams at the early preliminary design stage to show the magnitude and layout of the cathodic protection system. The designer must clearly define areas that will be protected and the areas that could be affected by interference, and steps to be taken to ensure other structures (pipes, tanks, etc.) are protected from interference.
- (d) Provide sufficient and properly located electrical bonds, electrical insulating devices, and corrosion control test stations to ensure adequate allowance for periodic inspection, review, testing, and examination of the system.

- (a) Regardless if other sections of the contract documents allow the use of specifications other than the UFGS (Unified Facilities Guide Specifications) for other portions of the design of this facility; ONLY the latest Corps of Engineers' edition of UFGS specifications will be allowed and shall be utilized in the cathodic protection design for the specification of cathodic protection systems. With regards to Cathodic Protection, this requirement applies also to Design- Build and RFP type contracts, which sometimes may allow the use of specifications other than UFGS specifications for other disciplines.
- (b) The cathodic protection systems provided on the metallic structures listed in this chapter shall be either impressed current or galvanic type systems as determined by the following requirements: 1) the pertinent design data as gathered by the "corrosion expert" (defined below), including but not limited to soil resistivity, material selection, coating selection, coating thickness, current requirements, anode selection, ability to isolate from foreign structures, etc. as necessary to meet the minimum potential criteria defined below; 2) full compliance with one or more of the properly edited and subsequently approved applicable guide specification(s) listed herein; 3) short runs (less than approximately 1000 feet) of all metallic pipelines (including ductile iron) that can be adequately and justifiably protected with galvanic cathodic protection systems, non-metallic pipelines with metallic components, and metallic components of other described structures requiring cathodic protection shall, as a minimum, comply with all the requirements of Unified Facilities Guide Specification (UFGS) section 26 42 14.00 10 (unless gathered data requires the use of an impressed current system); 4) protection of *all* metallic pipelines, which are too long (e.g., exceed 1000 feet) or have other design restrictions that prevent the use of a galvanic cathodic protection system capable of meeting required potential criteria, and the bottom surfaces of on-grade steel water storage tanks (if provided and installed in this project) shall, as a minimum, be protected with an impressed current cathodic protection system in full compliance with a properly edited and government approved Unified Facilities Guide Specification (UFGS) Section 26 42 15.00 10. Furthermore, the interior surfaces of metal water storage tanks, including riser piping if so equipped, shall be protected with an impressed current cathodic protection system in full compliance with a properly edited and government approved Unified Facilities Guide Specification (UFGS) section 26 42 13.00 10.
- (c) The design of the cathodic protection system shall be completed prior to construction contract advertisement except for Design-Construct and pre- approved underground heat distribution systems. That is, submission of an all-performance type design rather than a complete design, ready for construction, is not acceptable.
- (d) In addition to the soil and water resistivity surveys, current requirement tests and design, the designer shall provide recommended tests, formats, required methodology, etc., for the final acceptance of the cathodic protection system based upon the USACE cathodic protection acceptance criteria.
- (e) The design shall clearly provide thorough and comprehensive specifications and drawings. The design must meet the requirements of Army ETL 1110-3-474 and shall incorporate guidance from all referenced documents and other applicable criteria, such as NACE RP0169, NACE RP0177, NACE RP0187, NACE RP0188, NACE RP0190, NACE RP0193, NACE RP0285, NACE RP0286, NACE RP0388, NACE

RP0572, applicable Code of Federal Regulations (CFR), etc. The expected results shall be provided by field test (in the construction phase) witnessed by the Contracting Officer's representative.

- (f) The design must include applicable drawings, as available, showing existing construction. Verification of the validity of these drawings and/or any other data furnished by the Government shall be the responsibility of the designer.
- (g) The designer shall provide an updated cost estimate of the cathodic protection system. This will include all construction and testing costs related to installation of cathodic protection. The estimate shall be a detailed estimate showing equipment, labor, excavation, etc.
- (h) The design shall identify all locations for interference testing (all pipes that passes within 1000 feet of an impressed current anode bed and then crosses the cathodically protected line).
- (i) The design plans and specifications will show extent of the facilities to be protected; location and type of anodes; location of test points; locations of rectifiers, test stations, junction boxes, wiring, etc.; installation details; insulators; bond connections; and details for sectionalizing an underground piping system. Coordinate with mechanical, site, environmental, and other disciplines. This design shall be complete enough to purchase equipment and build, without design changes, to meet criteria of protection.
- (j) For non-metallic pipelines or other structure with buried or submerged metallic components, each buried or submerged metallic component shall have design calculations, a drawing detail of that component showing cathodic protection with at least one test station. Each component shall have a minimum of one test station, two anodes, and one permanent reference electrode. Each location shall be shown on drawings. Header cables shall not be used for connection of anodes. Each anode shall be connected to a test station via an individual lead conductor and bonded to the structure being protected inside the test station. The test station shall be connected to the structure being protected via two conductors.
- (k) Each new metallic pipeline connecting to an existing metallic pipeline shall be electrically isolated from the existing pipeline by the installation of an insulating flange. New metallic pipeline passing through concrete slabs, walls, and floors shall have an insulating material (such as a PVC sleeve) between the pipe and concrete to provide isolation. Insulating flanges shall also be installed in new metallic pipelines extending above grade or where they extend above floor slabs; the flanges are to be located above grade.
- (l) The cathodic protection designer shall coordinate his design with any existing cathodic protection systems around the new facility. As necessary, the contractor shall relocate any existing cathodic protection system test stations or other cathodic protection equipment located in areas conflicting with construction of the new facility. Any existing cathodic protection system equipment that must be moved shall be relocated to areas approved by the Contracting Officer's representative.
- (m) All potential tests shall be made at 2.5 ft. intervals witnessed by the Contracting

Officer's Representative. Design shall require that submittals identify test locations on a separate drawing showing all metal to be protected and all cathodic protection equipment. However, a minimum of 3 tests shall be made at each metallic component in the piping system. Test points, equipment, and protected metal shall be easily distinguished and identified on the drawings.

15.8.2.5 Criteria of Protection

Criteria for determining the adequacy of protection on a buried structure are defined in the following NACE International Publications: NACE RP0169, NACE RP0193, or NACE RP0285, as applicable. Criteria for determining the adequacy of protection on internal submerged surfaces of carbon steel water storage tanks are defined in NACE RP0388. For buried metallic components, the cathodic protection system shall meet the minimum criteria for steel, ductile iron, and cast-iron structures defined in the first subparagraph below (criteria indicated in the second subparagraph may be utilized as an alternative procedure if the first criteria procedure fails and if submitted to and approved by the Contracting Officer's representative prior to testing):

- (a) A negative voltage of at least minus 850 millivolts as measured between the structure or specified underground metallic component and a saturated copper-copper sulfate reference electrode contacting the earth (electrolyte) directly over the structure. Determination of this voltage shall be made with the cathodic protection system in operation and after it has been in operation for a minimum of 72 hours. Voltage drops shall be considered for valid interpretation of this voltage measurement. A minimum of minus 850 millivolts "instant off" potential between the structure being tested and the reference cell shall be achieved over 95 percent of the area of the structure. A close interval survey shall be conducted on all cathodically protected pipelines and components. The design shall be accomplished so that the protective current can be interrupted to obtain the "instant off" potential readings. Adequate number of measurements shall be obtained over the entire structure, pipe, or other metallic component to verify and record achievement of minus 850 millivolts "instant off." This potential shall be obtained over 95 percent of the total metallic area without the "instant off" potential exceeding 1100 millivolts.
- (b) A minimum polarization voltage shift of 100 millivolts as measured between the structure and a saturated copper-copper sulfate reference electrode contacting the earth directly over the structure. This polarization voltage shift shall be determined by interrupting the protective current and measuring the polarization decay. When the protective current is interrupted, an immediate voltage shift shall occur. The voltage reading, after the immediate shift (this reading shall be defined herein as being the same reading as the "instant off" reading described in the immediate paragraph above and this term will be utilized below), shall be used as the base reading from which to measure polarization decay. Measurements achieving 100 millivolts decay shall be made over 95 percent of the metallic surface. Alternatively, the "instant off" measurements can be compared to the native readings taken prior to energizing of the cathodic protection system and in the exact same locations. For comparison of "instant off" to native readings, the same number of measurements in corresponding locations must be taken. If the "instant off" reading is compared to the corresponding native reading in the same location, it must be a minimum of 100 mV more negative with respect to the copper/copper-sulfate reference cell than the native reading. The "Corrosion Expert" must assure that a complete set of native readings are taken prior to energizing the cathodic protection system at all the same locations as the "on" and "instant off" measurements are taken (i.e., close interval survey), as is required by the referenced guide specifications. The "instant off" measurements shall

be made after the system has been in operation for a minimum of 72 hours.

15.8.3 Other Electronic Systems

15.8.3.1 Leak Detection for Underground Storage Tanks

Leak detection must be provided for underground storage tanks and piping which will contain petroleum products or the hazardous materials as required by local, state, or federal regulation. The leak detection requirements are discussed in Chapter 14 ELECTRICAL AND ELECTRONIC SYSTEMS.

15.8.3.2 Grounding Systems

Grounding systems can cause special corrosion problems that must be properly resolved in the corrosion control and cathodic protection design. Extreme care must be exercised to avoid the interconnection of dissimilar metallic materials and to avoid interference problems and/or the compromising of the cathodic protection system. Refer to Chapter 14 ELECTRICAL AND ELECTRONIC SYSTEMS for guidance on electrical grounding systems.

Chapter 16 - Telecommunications

16.1 GENERAL

16.1.1 Scope

The mandatory technical requirements, parts, and materials register, and referenced applicable publications shall be adhered to, contained within this document, shall be incorporated within all project designs and contracts for implementation on the installation. Deviation from this guide requires 96th Communications Squadron (CS) approval. The telecommunications contractor(s) herein must coordinate with the 96th Communications Squadron concerning layout and configuration of all Outside Plant (OSP) and Inside Plant (ISP) cyber transport infrastructure. Refer to the current version of the 96th Communications Squadron “Eglin AFB Cable Installation Specifications” for details.

16.1.2 Communications and Information Systems Officer

The 96 CS/CC is designated by Technical Order (TO) 00-33A-1001 as the Communications and Information Systems Officer (CSO) for the base. The 96 CS/CC is the operational and maintaining authority for Cyber Infrastructure that supports the base and tenant units and has final approval over all Cyber Infrastructure processes, procedures, requirements, and installations.

16.2 APPLICABLE PUBLICATIONS

Building Industry Consulting Service International (BICSI)

Telecommunications Distribution Methods Manual 14 Volumes I & II

National American National Standards Institute / Telecommunications Industry Association

ANSI TIA 569-E Telecommunications Pathways and Spaces

ANSI/TIA 570-D Residential Telecommunications Infrastructure Standard

ANSI/TIA-606-C Administration Standard for Telecommunications Infrastructure

ANSI/TIA-607-D-2019 Generic Telecommunications Bonding and Grounding (Earthing) for Customer Premises

Unified Facilities Criteria (UFC)

UFC 3-580-1 Telecommunications Interior Infrastructure Planning and Design

UFC 4-010-05 Sensitive Compartmented Information Facilities Planning, Design, and Construction

UFC 4-010-06 Cybersecurity of Facility-Related Control Systems

UFC 4-510-01 Design: Military Medical Facilities

UFC 4-711-01 Family Housing

Chapter 17 - Cost Estimates

17.1 GENERAL

The purpose of this chapter is to provide specific guidance for the preparation of cost estimates for military construction projects. Estimates are made for programming, cost control during design, evaluation of bids, control of negotiations, and to serve as a guide in establishing a schedule of payments. Often these estimates are also used to evaluate the reasonableness of the contractor's proposal for negotiated procurement contracts. As such, they must be consistent with the best estimating practice of the construction industry and be current, accurate, and complete. They must reflect the expected cost to the Government to perform the work by contract and include all reasonable costs which a prudent, experienced, and well-equipped contractor might anticipate and include in his bid.

17.2 APPLICABLE PUBLICATIONS

Unified Facilities Criteria (UFC)

UFC 1-300-08 Criteria for Transfer and Acceptance of DoD Real Property, With Change 2

UFC 3-700 series Cost Engineering

Air Force Parametric Cost Engineering System User Guidebook (PACES)

Civil Works Work Breakdown Structure

Engineering Instructions (EI)

EI 01D010 Construction Cost Estimates

Engineering Pamphlet (EP)

1110-1-8, Volume 3 Construction Equipment Ownership and Operating Expense Schedule - Region III

Engineering Regulation (ER)

1110-1-1300 Engineering and Design Cost Engineering Policy and Requirements

ER 1110-2-1302 Engineering and Design Civil Works Cost Engineering

ER 1110-3-1300 Engineering and Design Military Programs Cost Engineering ER

1110-3-1301 Engineering and Design Environmental Restoration Cost Engineering

Hazardous, Toxic, Radioactive Waste Work Breakdown Structure

Historical Air Force Construction Cost Handbook

Military Work Breakdown Structure

17.3 GENERAL INSTRUCTIONS

- (a) The Cost Engineer is responsible for obtaining the current version of all software and applicable user manuals. MCACES 2nd Generation (MII) software can be obtained through the U.S. Army Engineering and Support Center, Huntsville, AL at:

www.hnd.usace.army.mil/traces

Air Force Parametric Cost Estimating System (PACES) software can be obtained from Earth Tech, 9100 E. Panorama Drive, Suite 200, Englewood, CO, 80112 at 303-771-3103 or

www.talpart.com/products/paces.

- (b) Projects shall be designed in U.S. measurements.

17.4 DELIVERABLES

The following items are to be included in estimate submittals:

- (a) Estimate. (Required for all submittals, number of copies specified in SOW). For manually prepared, the complete detail and required summaries; for MII, all material printed out in accordance with the “Project Template”, in reduced size (8-1/2”x11”), landscape, and suitably bound. MCACES 2nd Generation (MII). All electronically prepared cost estimates can be e-mailed to the Eglin AFB PM. The Ready-To-Advertise (RTA) cost estimate that is submitted to the Government shall be accompanied by a letter of transmittal, which includes the following statement: “To the best of my knowledge the confidential nature of this estimate has been maintained”. This statement should be signed, dated, and maintained until the official markings have been removed. A-E RTA estimates shall include all amendments that might occur during the advertising period.
- (b) Bid Schedule. (Required for all submittals.) Prepare in a format in accordance with instructions in Chapter 2 SPECIFICATIONS. During design, Bid Schedules frequently change as selected features may need to be covered under separate bid items. The final Bid Schedule will be as directed or approved by the Government.
- (c) AF Form 1178. (Required for all submittals on Air Force Projects only), properly filled out in accordance with the instructions below.
- (1) Blocks 1 through 59, excluding 14 and 46, are to be completed. If a block is not applicable, so state as N/A.
 - (2) Blocks 48 and 50 (Area Cost factor and Size Adjustment Factor) should be listed as N/A if actual area costs are used. If unit costs for common DOD facilities are used, the appropriate factors listed in the latest Tri- service report should be used.
 - (3) Compute Items 55 and 57 (Construction Contingency and SIOH) based on the appropriate percentage of Item 54f, Subtotal.

- (4) Reference Block 52:
 - a. The desired midpoint of construction (month/year) is to be calculated from Block 19, Construction Start, and Block 20, Months of Construction.
 - b. The midpoint of available estimate (month/year) is the date the cost estimate is prepared.
 - c. Both raw inflation indexes are to be obtained from the latest AF Cost Growth Factors via the Cost Engineering Branch Internet address.
- (5) The Supervision, Inspection and Overhead (SIOH) in Block 57 is to 5.7%.
- (6) ROM estimates must be in 50 division format
- (d) Depart of Defense (DD) Form 1354. (Transfer and Acceptance of Military Real Property) (Required at Final and RTA submissions.) must be prepared for specified military project as required.
- (e) Supporting Data. (Required for all submittals). A suitably bound, ordered and legible presentation of all cost estimate backup. Backup consists of Quantity Survey, Quantity Derivations and Quotations. All backups must be traceable to the line-item task in the cost estimate that the backup supports.
- (f) Spreadsheet. (Required at each submittal.) A spreadsheet should be prepared and submitted with each cost estimate submittal comparing the Current Working Estimate to the Current Programmed Amount.
- (g) Annotated Comments, as appropriate. Note: The various customers specified in the Task Order (TO) Statement of Work (SOW) will receive the Cost Estimate Plus AF Form 1178, if applicable.

17.5 ESTIMATOR QUALIFICATIONS

The designers cost estimating staff shall consist of dedicated full-time cost engineering specialist(s) for each required design discipline, such as architectural, structural, civil, mechanical, and electrical. It is imperative that estimates be prepared by, and reviewed under the supervision of, personnel who are competent in construction cost estimating. Estimators must possess a working knowledge of construction and be capable of making professional determinations based on experience. If the designer determines his staff does not possess all these qualifications, he shall obtain assistance from a qualified firm whose specialty is cost estimating. In making this determination, the designer shall consider the complexity of the project and the number and qualifications of his full-time estimators. In consideration and selection of a consultant firm for cost estimating, the designer shall consider, in addition to the foregoing, the firm's specialties, its ability to coordinate the estimates with the designer, and its previous experience in preparing cost estimates for the Government. Estimates prepared by a consultant must be reviewed by the designer before submittal to insure coordination and compliance with contract requirements.

17.6 METHODS OF ESTIMATING

17.6.1 General

- (a) The method(s) used to prepare estimates for the various required submittals shall be as specified in the Statement of Work-Cost Estimating Criteria. Method specified may be the Micro-Computer Aided Cost Engineering System (MCACES 2nd Generation (MII)); Tri-Service Automated Cost Engineering System (AF TRACES Parametric Building Models - PACES); Manual Method or Excel Spreadsheet Method as described below, or a combination of the above software systems.
- (b) Regardless of the method used, the designer shall make all necessary investigations, evaluations, calculations, and adjustments to ensure that the estimate fits the specific project scope and conditions, and is current, accurate and complete.

17.6.2 PACES Building Models

When PACES building models system is specified, the estimate shall be prepared as explained in the Statement of Work-Cost Estimating Criteria and the PACES User Manual and Site Work Model Report. Further detailed instructions and specific information will be provided separately as necessary by the Mobile District Cost Engineering Branch.

17.6.3 MCACES 2nd Generation (MII)

Under the MCACES 2nd Generation (MII) procedure, the estimate shall be prepared as explained in the Statement of Work-Cost Estimating Criteria.

17.6.4 Manual

When the manual procedure is directed or elected for a specific submittal, the estimate shall be prepared similarly to the sample final estimate which will be furnished if applicable. At the Ready-To-Advertise submittal, the estimate forwarded to Eglin CE shall be the original, prepared in pencil, in order that any necessary revisions by the Government may be readily made.

17.6.5 Excel Spreadsheet

When the Excel Spreadsheet method is directed, the estimate shall be prepared on the Excel Spreadsheet blank forms and similarly to the sample Excel Spreadsheet final estimate which will be furnished if applicable.

17.7 SUBMITTAL REQUIREMENTS

17.7.1 General

The designer shall prepare (or have prepared by an estimating consultant) a professional quality construction cost estimate at each of the various stages of project design. Estimates must accurately reflect the scope and features of work shown on the design documents submitted. The degree of detail must be commensurate with that represented by the submitted plans, specifications, design analyses, etc. Where the design is not sufficiently complete to enable accurate definition of any portion of the work, appropriate allowances, based on good estimating experience and judgement, must be made to cover work not yet fully defined.

17.7.2 Cost Control

Funds for project construction are usually programmed based on the estimated cost at the project definition or

concept design stage. Based on the programmed amount, which frequently cannot be increased, a Construction Cost Limitation (CCL) is determined. The designer is responsible for making every reasonable effort to design a project that can be built within the CCL, specified in the Statement of Work (SOW). Throughout the entire design period, close coordination between the designer and cost engineer must be exercised to achieve accurate cost control.

17.7.2.1 Cost Estimate Overruns

It is the designer's responsibility to design the project so that the current construction costs including project escalation costs are within the construction cost limitation specified in the SOW. However, if for some reason beyond the designer's control the project should exceed the construction cost limitation, the designer shall submit the following: (1) the cost estimate showing a base bid that is equal to or less than the construction cost limitation; (2) identify a list of additives alternates/options to bring the total bid package to no more than the construction cost limitation specified, that have been coordinated through Eglin AFB, Project Manager (PM); and (3) a written narrative explaining the reasons why the current construction costs including project escalation exceeds the construction cost limitation specified. A written narrative shall also be submitted whenever the current cost estimate has changed more than 5% (plus or minus) from the previous cost estimate. In the case of the project definition or concept cost estimate, variations from the DD Form 1391 shall be explained in narrative form.

17.7.2.2 Failure to Comply with Procedures

Failure of the designer to conform to the procedures outlined within this or referenced manuals will result in the estimate being rejected and resubmitted with deficiencies corrected and the designer may be required to come to the Eglin CE office within 48 hours for a face-to-face meeting for the purpose of preparing a corrected cost estimate.

17.7.3 Format

17.7.3.1 General

When PACES or MII is specified, the format will be as outlined in the Statement of Work-Cost Estimating Criteria. The Cost Estimate shall also follow the Tri-Services Work Breakdown Structure (WBS). In addition, a Work Breakdown Structure hierarchy (Normal, Full, Partial or Special) has been established for all MII estimated projects. Project information shall be input so that the estimate output will present costs for the building (or primary facility), broken down according to its various features, and costs for all support items. Any bid schedule, money allocations, etc. requirements shall also be considered. The PCACES system, after project/facility data has been established, models selected, project parameters defined, quantities and direct costs calculated, modifiers (overhead, profit, escalation, contingency, and SIOH) added, the system will generate various construction cost reports. MII software system will compute costs and generate an estimate after imputing applicable cost data and utilizing the various libraries. When an estimate is manually prepared, its format shall conform to the example provided, with similar breakdown of features and bid items. When an estimate is prepared using the Excel Spreadsheet method, its format shall also conform to the example provided, with similar breakdown of features and bid items.

17.7.3.1.1 Civil Works Projects

- (a) At the Reconnaissance Study or alternative evaluation phase of Feasibility Studies, rough-order-of-magnitude estimates based on historical costs can be prepared manually or using an Excel spreadsheet. Once a selected plan is determined a

detailed MII estimate must be prepared using the appropriate Civil Works Work Breakdown Structure (WBS) format. After which a Total Project Summary of Costs must be prepared using an Excel spreadsheet. This summary must be arranged by Code of Accounts format and include all project costs (e.g. Real Estate, Design, Engineering During Construction, etc.) and show the appropriate escalation.

- (b) At the Plans and Specifications (P&S) stage, all estimates must be prepared using MII and detailed equal to the level of design. The MII estimate should be arranged according to the project Bid Schedule included in the specifications and be formatted in the Civil Works WBS. The Total Project Summary of Costs must also be updated at this stage to reflect the current estimates.
- (c) At the RTA stage, the Government Estimate must be arranged according to the Bid schedule shown in the solicitation specifications. The Government Estimate must be prepared using MII to a level of detail commensurate with the solicitation drawings. The Government Estimate does not include Prime Contractor Profit.
- (d) For Civil Works Projects involving dredging, the cost estimate should be prepared using the appropriate CEDEP spreadsheet program in lieu of MII for the Dredging Account only.

17.7.3.2 Bid Schedule

For Project Definition submittals, estimated contract costs shall conform to a bid schedule like that expected to be developed later, with a minimum of at least one bid item for work within any building and at least one to cover exterior work. For later than concept submittals, estimates shall conform to an acceptable bid schedule proposed by the designer. Generally, each different building or building type must be covered under a separate bid item. Within a building, selected features or work items may be required to be covered under separate bid items for cost accounting or other reason. Exterior work may be required to be broken into separate bid items where quantities of work are significant and highly variable or where useful historical cost data can be derived from analysis of bids received. The estimate shall present a total amount for each bid item to include direct labor, material and construction equipment costs, indirect costs, and profit. The final bid schedule will be as directed or approved by the Government. If the estimated cost of the total project, including cost growth allowance, would exceed the CCL, it may be necessary that the bid schedule include items under a base bid and additive alternates /options. Where additional bid item breakdown beyond that proposed by the designer is considered necessary, it shall be provided by the designer at no additional cost to the Government. Estimates for modifications under an existing construction contract must conform to the contract pay item schedule. When the Statement of Work requires multiple Bid Schedules, preparation of separate detailed cost estimates and associated summaries is mandatory.

17.7.3.3 Contractor Type

The estimate shall be structured according to the type contractor considered most likely to bid as prime. For example, if the job is so heavy in mechanical work that most bidders would likely be mechanical contractors, the estimate should reflect a mechanical prime contractor.

17.7.4 Cost Breakdown

17.7.4.1 General

Costs must be broken down into priceable elements. All cost and quantities in the estimate must be supported.

Unsupported lump sum pricing is not acceptable at any stage of design. The level of breakdown must be commensurate with detail available from the design documents.

17.7.4.2 Project Definition (10-15%)

The Project Definition Cost Estimate should be as detailed as the level of design will permit. Unit pricing which includes all direct labor, material and construction equipment costs and any subcontractor markups is permitted, provided appropriate support is included. Prime contractor indirect costs and allowance for profit must be excluded from such unit prices and added separately.

17.7.4.3 Concept Design (30-35%)

The Project Definition Cost Estimate should be as detailed as the level of design will permit. Unit pricing which includes all direct labor, material and equipment costs and any subcontractor markups will be permitted up through the concept submittal, provided appropriate support is included. Prime contractor indirect costs and allowance for profit must be excluded from such unit prices and added separately.

17.7.4.4 Interim Design (50-60%)

The Interim Design Submittal Cost Estimate shall be prepared in task-by task detail to accurately reflect the scope of work shown in the submittal. This cost estimate provides good cost control prior to final design.

17.7.4.5 Final Design (Unreviewed 100%)

The Final Design Cost Estimate shall be prepared in task-by-task detail to accurately reflect the scope of work shown in the submitted documents. At the Final submittal, since design is complete, the scope of work is defined sufficiently well to permit accurate and complete determination of all project costs.

17.7.4.6 Ready-to-Advertise (100%)

At the Ready-To-Advertise submittal, a final update of the Final submittal, the estimate will be comprised entirely of work tasks for which basic costs are detailed. The designer is responsible for the complete cost estimate including amendments that might occur during the advertising period. This cost estimate should be submitted to AF PM 4 days prior to the final bid/proposal opening date.

17.7.5 Resubmittal and/or Support

If upon review, any submitted estimate is found to not follow any of the requirements stated or referenced in these instructions, it will be rejected. The designer shall, promptly upon request, revise and resubmit the estimate in the time specified in the resubmittal notice, with deficiencies corrected, at no additional cost to the Government. If cost, quantity, etc., of any item in the estimate appears questionable, the designer shall promptly provide sufficient and satisfactory explanation and/or supporting data.

17.7.6 Bid Exceeds Estimate

- (a) After all bids are received and they are significantly higher than the Government Estimate to be determined unreasonable, there is a possibility that one or more bidders will protest the reasonableness of the Government Estimate. In addition, the designer/cost consultant Final Bid Price Estimate may not be within 15 percent of the low responsive bid at bid opening time. If this occurs, the designer has a major role in reviewing the Government Estimate and evaluating the Government's position. The

designer/cost consultant will promptly conduct an independent review of the Government estimate at no additional cost to the Government. The responsible cost engineer would review the Government Estimate to be sure that it does not contain any omissions, discrepancies (errors in calculation, etc.), quantity takeoff errors, or errors in cost/pricing data. In addition, the reviewer should further analyze any unusual conditions or circumstances that may affect or complicate the work. If the reasonableness of the Government Estimate is protested, the analysis will consist of an in-depth, point-by-point response to all issues raised by the protestor or contractor. The review/analysis will consist of the Government Estimate, including all backup and supporting data, complete explanations about assumptions made and, if available, historical data from previous similar projects which support the estimate. The Government Estimate should be revised immediately if an error is found, and an explanation of the error should accompany the revised estimate. If the revised estimate brings an offeror's price within range of a fair and reasonable price, the Contracting Officer will review the situation and determine final contracting action.

- (b) The designer is required to accomplish the design to permit the award of a contract at a price that does not exceed the construction cost limitation specified. When bids for the construction contract exceed this amount, the Eglin CE may enforce the contract clause requiring the designer to perform such redesign necessary to permit award within funding limitations. These services shall be performed at no increase in the cost to the Government.

17.8 TECHNICAL REQUIREMENTS

17.8.1 General

Estimates must accurately reflect the project scope and conditions, local labor situation and prices of material, labor, and construction equipment anticipated or forecast to prevail in the project vicinity at the time of construction, based on a practicable construction schedule. The estimate should consider delivery dates for materials and equipment to be installed. Estimates will not be accepted as meeting contract requirements if data used in their preparation is substantially different from that shown on the submitted drawings or other design data. Very close coordination and clear communication among the designers and estimators is required because reliable, accurate estimates cannot otherwise be produced.

17.8.2 Quantity Survey

- (a) Accuracy and completeness of the quantity survey (takeoff) is essential as it directly and critically affects the accuracy of the estimate. The takeoff shall be comprehensively and accurately prepared to cover all work for the project. It shall be based on all facts that can be gathered from the available engineering and design data. Assumptions as to detail which is beyond the level available at the current stage of design is often necessary to ensure that total cost of the overall project work is covered. In such cases, statements and explanations of necessary assumptions shall be included so that, when design details become available, quantities can be reconciled. Quantity surveys must be planned to fit the pricing for the work involved, conform to the bid schedule, and be consistent with the payment provisions of the specifications. Surveys must be documented in such manner that computations can be later followed and verified by others. Tabulation and computation sheets shall be dated and contain appropriate references to plans, specifications, or design analyses. Relevant sketches shall be included.

- (b) The importance of accurate and concise quantity take-off to the cost estimate cannot be overstressed. The following procedures and exhibits must be followed for the designer to have an acceptable cost estimate. If a spot check of quantities by AF PM reveals inaccuracies or the required format has not been used in the preparation of the cost estimate, the estimate will be rejected and must be resubmitted with the deficiencies corrected. The quantity take-off is required to follow the applicable WBS.
- (c) The quantity take-off and cost estimate shall be treated in a confidential manner and only those personnel concerned with the preparation and/or review of the project shall have access to it. The cost estimate will be utilized in preparing government estimates for evaluating bids and shall be classified "FOR OFFICIAL USE ONLY". Such material cannot be divulged to other than accredited Government personnel with a need to know. Information contained within estimates shall not be divulged to prospective bidders. Parametric measurement(s) such as lump sums, building costs by square foot of area, etc. for all estimates are not permissible and estimates utilizing such will be rejected.
- (d) Prepare a quantity take-off in accordance with appropriate WBS showing all quantities used in the cost estimate. The estimator shall show all assumptions as to scope and design used in preparation of the cost estimate. These assumptions shall include WBS systems contained within the project. Proper allowances shall be made for WBS system and subsystems not completely determined in the plans, specifications, and design analysis. The quantity take-off and cost estimate shall be an accurate representation of the complete design submitted. Quantity take-offs shall not be written on the drawings themselves. The quantity take-off shall be prepared in a manner that is clearly legible, indicating the calculations involved in determining the quantity and any assumptions the estimator has made in determining the quantity. The take-off shall contain backup and supporting sheets showing breakdowns for all quantities of all materials contained within the design drawings and/or specifications.
- (e) The top of each quantity take-off sheet shall contain the following information: (1) project information; (2) the design stage; (3) the drawing file number and/or specification section & paragraph number from which the quantity was derived; (4) facility name, quantity, and Unit of Measure (UOM); (5) WBS code where the quantity is located in the cost estimate; and (6) the date and initials of the estimator who prepared them as well as the initials of the estimator who checked them. All quantities and quantity calculations must be clearly traceable to the to the cost estimate item that they support.

17.8.3 Material Pricing

When an item of material is relatively minor or not yet fully defined, as at concept or earlier stage, it may be satisfactory to base pricing on data in estimating handbooks (including the MII Cost Book Library). In these cases, appropriate adjustments must be made to account for project conditions. For later stages or for significant items, material costs will be based on verbal or written quotations obtained from manufacturers

and suppliers, price lists appropriately discounted, and previous recent quotations. Specific current price quotations (at least two, if practicable) should be obtained for major items of permanent equipment and for significant, unusual, or nonstandard material items. Where quantities or unit costs will have only moderate impact, recent reliable quotations from other projects for comparable items are considered acceptable. Freight costs to the project site must be covered. Sales and other applicable taxes must be included in the estimate by applying, in a separate calculation, appropriate percentage markups of material cost. Guide for Estimating sales Taxes can be downloaded off the Internet (See Paragraph 17.3 above). Each submittal for which quotations are appropriate shall include a list showing principal items of material, equipment, and supplies (such as concrete, structural steel, siding, pumps, chillers, uninterrupted power system, etc.), and indicating the manufacturer/supplier, location, person contacted, telephone number, date, pricing, etc., along with all other pertinent information collected or prepared for the estimate.

17.8.4 Labor

17.8.4.1 Wages

Labor costs in the estimate must be based on rates that include basic wages, overtime and holiday premium payments, and Contractor's contributions for fringe benefits such as health and welfare, holiday and vacation pay, pension fund, apprentice training, etc. Estimated rates should be those which the contractor will be expected to pay when the project is constructed and must consider prevailing rates actually being paid in the project area as well as minimum rates which will be included in the contract in accordance with the requirements of the Davis-Bacon Act. Ultimately, the designer is responsible for all wage rates used in the cost estimate.

17.8.4.2 Unit Costs

17.8.4.2.1 General

Labor unit costs should be based on estimated productivity and cost of wages, fringe benefits, etc. for the labor involved. Productivity estimates are based on experienced rates tempered by estimators' judgement and must consider project conditions, labor availability, market conditions, and the like. Useful information can be obtained from vendors, subcontractors, and other pertinent sources.

17.8.4.2.2 PACES

PACES does not use specific project location wage rates to develop unit costs, but uses location modifiers to adjust material, labor, and construction equipment costs based on the location of the project. However, PACES scope and cost can be exported to MCACES 2nd Generation MII where specify line items can be adjusted.

17.8.4.2.3 MCACES 2nd Generation (MII)

For MII estimates, labor unit cost is a function of the crew unit cost and the value for crew daily output included for each task. The productivity rates in the MII project must be adjusted for project conditions as appropriate.

17.8.4.2.4 Manual or Excel Spreadsheet

Productivity must also be carefully evaluated for Manual or Excel Spreadsheet estimates. For mechanical and electrical work, labor cost must be estimated by assigning unit manhours to each task, then applying an appropriate prevailing wage rate to the summarized manhours. For work other than mechanical and electrical,

labor may generally be estimated by applying to each task a realistic unit cost (based on a reasonable task productivity and current prevailing wage rates), unit manhours, unit crew hours, or as directed. Where the labor cost for a specific task in a manually prepared or Excel Spreadsheet prepared estimate is significant, or the task has unique requirements, the submittal should include a detailed estimate based on productivity and cost of an appropriate crew like the example provided.

17.8.4.2.5 Social Benefits Cost

The contractor's cost for Social Security taxes (FICA), Federal and State Unemployment Insurance, Workmen's Compensation and Employer's Liability Insurance and any other social benefits must be included in the estimate as a percentage of the labor costs. Guide for Estimating Payroll Taxes & Insurance can be downloaded off the Internet (See Paragraph 17.3 above).

17.8.5 Construction Equipment

TRACES does not use specific project location construction equipment costs, but uses location modifiers to adjust material, labor, and construction equipment costs based on the location of the project. For MII estimates, costs for construction equipment and small tools costs are included in the equipment rates library. These costs are thereby included by the system for each task, as appropriate. For manually prepared or Excel Spreadsheet estimates, costs shall be computed similarly to the crew method of MII and included in the detail for the work item to which it pertains. EP 1110-1-8 is the basis for MII construction equipment unit costs and shall be used as well for estimating construction equipment costs for manual or Excel Spreadsheet cost estimates. Sometimes extraordinarily large numbers or highly specialized, unusual, or unique items of construction equipment may be required to construct a project. In any instance where it is considered likely that the Contractor would have to rent certain construction equipment, rental rates should be determined for those items and appropriate adjustments included in the cost estimate to cover any additional cost.

17.8.6 Subcontract Work

Estimates shall be prepared for subcontract work using the same methodology and degree of detail for direct costs as outlined for work by the prime contractor. All Subcontractor work must be detailed. Subcontractor quotations in lieu of detail are unacceptable. The subcontract estimate shall include costs for direct labor, materials, equipment, and second-tier subcontracts, as well as subcontractor mobilization and other indirect costs and profit. A subcontractor's overhead usually bears a fairly stable relationship to the subcontractor's portion of the work and can be estimated on a percentage basis. Overhead rates typically range from 10 to 15 % and profit rates from 7 to 10 %, depending on complexity, risk, etc., and judgement must be exercised in selecting appropriate rates. For second-tier subcontract work, overhead and profit markups must be covered for second-tier as well as first-tier. A detailed derivation of subcontractor's overhead costs will be required where his work has unique requirements or where the cost impact of the subcontracted work is significant. When reliable subcontractor quotations are obtained, they may be used to verify the reasonableness of the estimate for the subcontract work.

17.8.7 Mobilization and Demobilization Costs

These costs must be estimated by detailed analysis considering equipment requirements, distance to move to project site, transportation methods, effort required to prepare, service, load, unload, etc., and the detail included in the submittal. For most building-type projects, mobilization and demobilization for the prime Contractor may be included in the estimate of indirect costs. Subcontractor mobilization and demobilization cost should be included in the estimated subcontract total. Where costs apply primarily to certain work items, e.g., for specialized equipment, they should be appropriately distributed to applicable items.

17.8.8 Indirect Costs

17.8.8.1 General

For concept or earlier estimates where direct cost items may be estimated by experienced unit prices, use of empirical markups for prime contractor is acceptable. For later-than-concept estimates, all field indirect costs for the project must be estimated in detail and then distributed logically to the various items in the bid schedule. Home office expense will normally be prorated to all bid schedule items.

17.8.8.2 Field Indirect Costs

These include such costs as those for field supervisory, administrative, and technical personnel, offices, shops, yards, utilities, communications, office and engineering supplies and equipment, etc. expected to be incurred at the project site but not chargeable to a specific work item. **Exhibit 18-1** lists some items of field indirect cost. The list is not all-inclusive but is indicative of the type costs which are to be considered.

17.8.8.3 Home Office Expense

These costs will typically be included in estimates by applying an estimated percentage to the expected total field (direct plus indirect) cost amount. A contractor's home office expense rate is not fixed but varies from period to period. It is considered a function of his total general and administrative expense for a specific period divided by his total field costs for that same period. A reasonable average range of rates is estimated to be from 2% for larger to 7% for smaller contractors.

17.8.9 Profit

The estimate shall include appropriate allowances for profit. For the prime Contractor and for subcontractors whose work is a significant portion of the project, rates for profit allowance will be determined by the Weighted Guideline method. For less significant subcontract work, experienced percentage rates may be used.

17.8.10 Bond

Costs for performance and payment bonds shall be included in the estimate. Specific rates are dependent on factors such as the type of work to be performed, the contract amount, and the time allowed for completion.

17.8.11 Contract Modification Estimates

In certain instances, the designer will be tasked to prepare estimates for a modification to an ongoing construction contract. Such estimates are used as a basis of negotiations with contractors for additions to or deletions from a project, or both, and shall be carefully prepared in accordance with the applicable instructions in this chapter, as well as any supplemental information or instructions to be furnished by Eglin CE.

17.8.12 Current Working Estimate (CWE)

The CWE is defined as the latest available cost estimate for a particular project and should represent, as closely as possible, the total expected cost to construct the project. It must include the estimated contract cost as of the date of preparation, an allowance for cost growth, as applicable, an amount for contingency reserve to cover unforeseen developments during the actual construction which will result in additional costs, and an allowance for Government supervision and administration (S&A). To account for any cost increases which are anticipated to occur between the estimate preparation date and the actual construction period, an allowance for cost growth must be made. This will ordinarily be accomplished using a percentage factor developed from

a cost escalation index. Guidance for construction contingency allowance and S&A costs are outlined in the Statement of Work-Cost Estimating Criteria.

17.8.13 Quality Assurance

See **Exhibit 18-2** Technical Quality Control Checklist. This checklist may be used by the cost engineer to ensure the cost estimate submittal is complete.

17.8.14 DD Form 1391

Military Construction Project Data, if available.

17.9 SCOPE

Estimates shall be based on the most recent and complete design information available and shall follow the format of the appropriate Work Breakdown Structure (WBS). There are three (3) separate Work Breakdown Structures: Military, Environmental Restoration, and Civil Works. The Military WBS shall be used for all vertical building construction whether Military, Environmental or Civil Works funded.

Environmental Restoration projects shall use the Hazardous, Toxic, Radioactive (HTRW) WBS (funded by DERO, Superfund, DOE, etc.). The Civil Works WBS shall be used for large earth moving/dredging projects normally funded with non-military funds.

EXHIBIT 17-1
FIELD INDIRECT COSTS

1. Supervisory and Administrative Personnel
 - Field Project Manager
 - General Superintendent
 - Assistant Superintendents
 - Construction Trade Superintendents
 - Equipment Superintendent

2. Engineering Personnel
 - Project Engineer
 - Office Engineer
 - Quality Control Engineers
 - Surveyor and Surveymen
 - Draftsmen

3. Office Staff
 - Office Manager
 - Payroll Clerk
 - Clerk-Typists
 - Purchasing Agent
 - Janitor

4. Miscellaneous Staff
 - Safety Engineer, Nurse, First-Aid Attendant
 - Warehousemen
 - Clerks
 - Security Personnel

5. Job Expenses
 - Office Facilities
 - Shops, Warehouses, and Yards
 - Laboratory and Testing Expense and Facilities
 - Night Lighting Work Area
 - Construction and Maintenance of Access and Haul Roads
 - Office and Engineering Supplies and Equipment
 - Water, Power, Telephone, Radios, Sanitary Facilities
 - Project Sign and Bulletin Board
 - Vehicles and Transportation Expenses
 - Travel, Subsistence, Housing, etc. for Key Personnel
 - Permits, Easements and Rights-of-Way
 - Builder's Risk Insurance
 - Environmental Protection, Dust Control, and Restoration
 - Progress Schedules and Reports
 - Job Cleanup

EXHIBIT 17-2
TECHNICAL QUALITY CONTROL CHECKLIST

This checklist should serve as a tool to ensure that all areas of the cost estimate are properly prepared and adequately reviewed.

GENERAL

Has the reviewer been provided:

- A complete detailed cost estimate?
- All supporting backup?
- All applicable design documents (plans, specifications, design analysis, etc.)?
- Annotated Comments?

Has cost estimate been approved by the Eglin PM?

Does the reviewer have a clear Definition of Scope?

Has the estimator(s) visited the project site?

Is the Sign-thru Cover Sheet for the Government Estimate that discloses the overall project cost estimate stamped "FOR OFFICIAL USE ONLY"?

Has the Project Manager been notified of the estimated price versus the available funds?

CONTRACT REQUIREMENTS (A-E/COST CONSULTANT ONLY)

Has the Cost Estimate Submittal Checklist been provided?

Has the Cost Estimate been submitted in the required number of copies, suitably-bound, in landscape?

Was ENG Form 1354 provided?

Was AF Form 1178 provided (AF Projects Only)?

Were the specified diskette(s) provided?

Was all cost estimate supporting data provided?

BID SCHEDULE

Does the Bidding Schedule contain Bid items for the following work features, if applicable?

Each Building to the 5 ft line?

Major site features (e.g. Sanitary Sewer System, Exterior Electrical Distribution, Parking Lot, etc.)?

Design Costs?

Asbestos Abatement?

Unit Cost Items (e.g. Rock Excavation, Unclassified Excavation, etc.)?

Pre-Wired Work Stations?

- Project Manager/Customer Requested Items?
- Separately Funded Items (e.g. OMAR Equipment, etc.)?
- Additive Alternates?
- Options?

FORMAT

- Has all required summaries been furnished?
- Has the required detail been furnished?
- Has the correct software been used?
- Were the correct Cost Libraries used in preparing the cost estimate?
- Is the cost estimate in the required Work Breakdown Structure (WBS) to Level 4 (Subsystem)?
- Is the cost estimate structured according to the type contractor most likely to bid as prime?
- Has a sufficient number of subcontractors been developed for the project?
- Is a majority of the work selected to be done by the prime contractor or subcontractor(s) according to normal construction practice?
- Does the cost estimate include escalation, construction contingency and SIOH?
- Is the cost estimate so structured to be directly comparable to the project Bid Schedule?
- Is the Scope-Of-Work adequately defined in the Project Notes?
- Can the cost estimate be compared to the "1391"?
- Is the cost estimate within the Construction Cost Limitation (CCL)?
- If the cost estimate is more than the CCL, have Additive Alternates or Options been identified that bring the Base Bid within the CCL?
- Have all amendments been acknowledged in the cost estimate?
- Has the cost estimate been compared to the previous cost estimate?
- If the cost estimate has changed more than 5% (+ or -) from the previous cost estimate, has reasons why been documented?
- Have all "assumptions" been documented in the cost estimate?
- Are all detail tasks in the cost estimate sufficiently described?
- Have specialty construction tasks (e.g. scaffolding, noise & dust control, phasing, etc.) been included in the cost estimate?
- Are "Units of Measure" proper?

MAGNITUDE OF DETAIL

- Is the Level of detail commensurate with detail available from the design documents?
- Does the cost estimate include all design amendments?
- Have MII task overrides been sufficiently utilized?
- Does the cost estimate contain any unsupported lump sums?

BACKUP

- Has all Backup (Quantity Takeoff, Quantity Derivations and Quotations) been furnished?
- Is all Backup traceable to the line item task in the cost estimate that it supports?
- Is Backup clear and understandable?
- Was sufficient quotations furnished?
- Was Backup current?
- Do quantities appear to be reasonable?
- Is Quantity Takeoff sufficient?
- Are Quantity Derivations clear and properly prepared?
- Did the reviewer spot check critical cost items and quantities?

DIRECT COSTS - MATERIAL

- Are all major material items supported by a current quotation?
- Does quotation used include all applicable costs (e.g. manufacturer/supplier, location, person contacted, telephone number, date, freight to job site, etc.)?
- Is Sales Tax in the cost estimate?
- Is Sales tax shown correctly for project area?

DIRECT COST - LABOR

- Have the wage rates been compared to the Davis-Bacon minimum wage rates?
- Does the wage rates reflect the local prevailing wage rates?
- Does the total wage rate shown include basic wage rate, fringes, OT, payroll taxes & insurance, etc.?
- Do the labor productivities used consider project conditions, labor availability, market conditions, etc.?

DIRECT COST - CONSTRUCTION EQUIPMENT

- Has Construction Equipment Cost for major items been included in the cost estimate?
- Has small tools cost been included in the cost estimate?

Has any construction equipment been included using “rental” rates?

SUBCONTRACTED WORK

Has subcontractor work been included in the cost estimate?

Is all major subcontractor work detailed? Note: Minor work maybe unit priced.

Does the project contain any work that is normally done by a 2nd Tier Subcontractor Work (e.g. Controls, Test & Balance, Insulation, etc.)?

Were subcontractor quotes obtained to verify the reasonableness of the of the estimate for the subcontractor work?

Were subcontractor markups reasonable?

PRIME CONTRACTOR OVERHEAD

Is all Prime Contractor Field Overhead detailed?

Has the Prime Contractor Field overhead been prorated to all Bid Items proportionally to the direct costs?

Have those items in the specification “Special Clauses” that are normally considered “Field Overhead Items” been incorporated into the cost estimate?

Is the Prime Contractor Field Overhead reasonable?

Has Mobilization/Demobilization costs been included in the cost estimate?

Do overhead salaries shown include an allowance for payroll taxes & insurance?

Are all overhead fixed costs included in the Base bid?

Is Prime Contractor Home Office Expense included in the cost estimate?

Is the Prime Contractor Home Office Expense reasonable?

PROFIT

Was Prime Contractor Profit included in the cost estimate?

Was Profit for the Prime Contractor determined using the “Weighted Guideline Method”?

Were the fixed cost (Size of Job, Period of Performance, Amount of Subcontracting) portion of the “Weighted Guideline Method” done correctly?

Were the judgmental factors (Degree of risk, Relative Difficulty of Work, Contractor’s Investment, Assistance by Government) reasonable?

BONDS

Has Bond been included on the entire contract amount?

Has Bond cost been calculated?

Is Bond cost reasonable?

COST ESCALATION

Was Cost Escalation included in the cost estimate?

Were all construction costs escalated to the "Midpoint of Construction? Note: Army - Escalate from Midpoint of Estimate to Midpoint of Construction, AF - Escalate from Date of Submittal to Midpoint of Construction.

Have "indices" and "dates" been shown?

CONSTRUCTION CONTINGENCY

Was a Construction Contingency percentage shown in the cost estimate?

Is the percentage correct?

SUPERVISION & ADMINISTRATION COST

Was a SIOH or S&A percentage shown in the cost estimate?

Is the percentage correct?

MODIFICATIONS

Has field office/cost estimator discussion been held?

Has adequate information been received to reflect actual contractor rates?

Has the original scope and changed scope been clearly defined?

Is the net change in scope presented clearly?

Does the estimate include costs and time for the impact on the unchanged work?

Were current, actual labor rates utilized?

Is backup and support for the estimate pricing available?

DREDGING

Was CEDEP used to prepare the cost estimate?

Does the narrative document the decisions and selections made within CEDEP?

Has effective working time been calculated considering lost time, weather delays, etc.?

Have estimate results been compared against historic information and reconciled if necessary?

Has the estimate been compared against data from similar projects?

Have production rates been calculated considering pumping rate, travel time, line size, navigational delays, etc.?

Have environmental requirements (beach and offshore) been included?

Does the estimate reflect correct environmental windows for the project area?

EXHIBIT 17-3

CREATE A NEW PROJECT CHECKLIST

- The correct libraries (Models, Assemblies, Unit Prices, Crews, Labor Rates, Equipment Rates) are present in the Database Window.
- The correct WBS Project Template has been selected.
- The Project Template has been copied to new six characters ID for this project.
- The New Project has now been selected, and name of project edited.
- Prime and subcontractors have been edited.
- The correct number of Facilities has been created.
- The required Assembly Titles for all Primary and Support Facilities have been created and detailed items entered into the Assemblies.
- All System, Subsystem, and Assembly Category Titles not required in this project have been deleted and the Project has been Packed.
- All subcontractors not required in this project have been deleted.

EXHIBIT 17-4

PRINT SUBMITTAL REPORTS CHECKLIST

- All cost and pricing is entered based on the Current Design Status.
- Costs for Systems and Subsystems not shown in the design have been accounted for in the estimate.
- Titles (Facility, System, Subsystem, etc.) at all levels not applicable to this project have been deleted.
- Prime Contractor's Field Overhead has been itemized to reflect project requirements.
- Prime contractor's Bond has been set to calculate a Class B Bond.
- Prime Profit has been calculated by the Weighted guideline Method.
- Subcontractor's Overhead has been set as a percentage.
- Subcontractor's Profit has been set as a percentage.
- Prime and Subcontractors have been assigned at the appropriate locations within the project.
- Any Subcontractors not applicable to this project have been deleted.
- Sales Tax has been entered.
- Escalations, Construction Contingency and SIOH have been set.

[] Estimate Status (35%, 60%, 95% etc.) has been entered in the Report Title field or the Print Selected Reports Window.

[] Two hard copies of the Submittal Estimate have been made.

EXHIBIT 17-5

CONTINGENCIES AND SUPERVISION & ADMINISTRATION (USE THESE VALUES UNLESS DIRECTED OTHERWISE)

	AIR FORCE
CONTINGENCIES	
NEW WORK	5%
ALTERATIONS & MODERNIZATION	10%
ADDITIONS/ALTERATIONS	5%-IF ADDITION IS LARGEST 10%-IF ALTERATION IS LARGEST
S&A (SIOH)	
NEW WORK	6.0%
ALTERATIONS & MODERNIZATION	6.0%
INSTALLATION SUPPORT	N/A

Chapter 18 - Antiterrorism/Force Protection (AT/FP)

18.1 GENERAL

18.1.1 Scope

This chapter provides guidance for preparation and development of projects in accordance with the Department of Defense (DOD) AT/FP requirements. Specific design submittal requirements in this chapter supplement the requirements in Chapter 1 GENERAL INSTRUCTIONS. Refer to Appendix 18 for Eglin Specific Criteria.

18.2 APPLICABLE PUBLICATIONS

Unified Facilities Criteria (UFC)

UFC 1-200-01 General Building Requirements

UFC 4-010-01 DOD Minimum Antiterrorism Standards for Buildings

UFC 4-010-02 DOD Minimum Antiterrorism Standoff Distances for Buildings (For Official Use Only (FOUO))

UFC 4-023-03 Design of Buildings to Resist Progressive Collapse

18.3 PROJECT DEFINITION (10-15%)

18.3.1 General Considerations

AT/FP design shall be integrated into the overall facility design from the beginning of the project. At the Project Definition phase, the designer shall investigate the AT/FP measures required for the project. The designer shall determine if the setback distances required for conventional construction can be provided within the project constraints or if further analysis and building hardening is likely to be required. In addition, any building elements requiring special design, such as mail rooms, equipment enclosures, progressive collapse, etc. shall be noted for use in preparing the cost estimate.

18.3.2 Narrative

The Project Definition narrative shall include, but not be limited to, the following items as applicable:

- (a) List all antiterrorism/force protection references used in the Project Definition design including Government design documents, industry standards, and criteria given to the designer at the charrette or predesign meeting.
- (b) List the building category, the location of the facility within a controlled perimeter, and the level of protection required.
- (c) Indicate the setback distances to be provided and describe the proposed construction to meet antiterrorism/force protection requirements.
- (d) Describe any progressive collapse requirements and their impact on the structural system provided. Discuss how continuity, redundancy, or energy dissipating capacity

will be provided in the structural system.

- (e) List any building elements such as mail rooms, equipment enclosures, etc. requiring special design to meet antiterrorism/force protection requirements and describe the proposed design solution. These items shall be noted for use in preparing the cost estimate.

18.4 CONCEPT DESIGN (30-35%)

18.4.1 General Considerations

The antiterrorism/force protection design shall be included in the drawings, calculations, and design analysis of each discipline involved. Antiterrorism/force protection design shall be to the concept design level required by the applicable design discipline, as stated in this document.

18.4.2 Design Analysis

The Concept Design analysis shall include a separate section on antiterrorism/force protection design. This section shall include but not be limited to the following items as applicable:

- (a) List all antiterrorism/force protection references used in the Project Definition design including Government design documents, industry standards, and criteria given to the designer at the charrette or predesign meeting.
- (b) List the building category, the location of the facility within a controlled perimeter, and the level of protection required.
- (c) Note the setback distances to be provided and describe the proposed construction to meet antiterrorism/force protection requirements.
- (d) Describe any progressive collapse requirements and their impact on the structural system provided. Discuss how continuity, redundancy, or energy dissipating capacity will be provided in the structural system. The discussion of the design solution shall reflect the level of a concept design, as described in this document for the structural discipline.
- (e) List any building elements such as mail rooms, equipment enclosures, etc. requiring special design to meet antiterrorism/force protection requirements and describe the proposed design solution. The proposed design solution shall be developed to the level of a concept design, as described in this document for the discipline involved.

18.5 INTERIM DESIGN (50-65%)

The antiterrorism/force protection design shall be included in the drawings, redlined marked up specifications, calculations, and design analysis of each discipline as appropriate for the type of project. Antiterrorism/force protection design shall be to the Interim Design level required by the applicable design discipline. In addition, the designer shall incorporate or answer all comments received from the Concept Design submittal review.

18.5.1 Design Analysis

The Interim Design Analysis shall include a separate section on antiterrorism/force protection design. The Interim Design Analysis shall include all the information required in the Concept submittal advanced to

Interim Design level.

18.6 FINAL DESIGN (UNREVIEWED 100%)

The antiterrorism/force protection design shall be included in the drawings, calculations, and design analysis of each discipline as appropriate for the type of project. The Antiterrorism/force protection design shall be to the final design level required by the applicable design discipline. In addition, the designer shall incorporate or answer all comments received from the Interim Design submittal review.

18.6.1 Design Analysis

The Final Design Analysis shall include a separate section on antiterrorism/force protection design. The Final Design analysis shall include all the information required in the Interim submittal advanced to Final Design level.

18.6.2 Specifications

Final edited specifications shall be submitted in accordance with Chapter 2 SPECIFICATIONS. Specifications shall include all antiterrorism/force protection requirements such as loadings for window and door frames and special glazing.

18.7 READY-TO-ADVERTISE (REVIEWED 100%)

The comments generated concerning the Final submittal shall be incorporated in the design analysis, drawings, and final edited specifications before they are submitted as "Ready-to-Advertise."

18.8 TECHNICAL REQUIREMENTS

18.8.1 General Considerations

Project design shall incorporate mandatory DoD standards for new buildings and for existing inhabited buildings, when triggered, in accordance with UFC 4-010-01. To the extent possible within the project constraints, the "Recommended Additional Antiterrorism Measures for New and Existing Buildings" UFC 4-010-01, Appendix C, shall also be incorporated. Antiterrorism/force protection design shall be integrated into the overall facility design from the beginning of the project through coordination of all disciplines. Antiterrorism/force protection requirements shall be met in the most effective and economical method. These methods include maximizing standoff distances, preventing building collapse, minimizing hazardous flying debris, providing effective building layout, limiting airborne contamination, providing mass notification, and facilitating future upgrades. Antiterrorism/force protection requirements shall be coordinated with all other applicable DoD building and design criteria and policies. Where other criteria mandates more stringent requirements, the provisions of those criteria will be followed.

18.8.2 Site

- (a) The civil/site design shall incorporate applicable requirements for minimum standards for force protection from UFC 4-010-01. Specific instructions for the minimum setback distances that apply to all new and existing (when triggered) facilities are shown in Appendix "B", Table B-1 and Figure B-1 in the UFC.
- (b) Additional antiterrorism measures that significantly enhance site security listed in Appendix "C" shall be incorporated into the site design for every new and existing (when triggered) facility to the maximum extent possible.

18.8.3 Landscape Architecture

The landscaping design shall incorporate applicable requirements from UFC 4-010-01. Specific instructions for specifying and locating planting materials and site furnishings within the “Unobstructed Space” are contained in that regulation.

18.8.4 Architectural

The following are requirements that shall be included in the architectural design for every new and existing, when triggered, inhabited building:

- (a) Glazing and window, skylight, and glazed door frames shall be designed in accordance with the special provisions of UFC 4-010-10, Appendix B, paragraph 3.1.
- (b) The main entrance to a new inhabited building shall not face an installation perimeter of other uncontrolled vantage point with direct line of sight to the entrance. If the main entrance to an existing inhabited building faces the installation perimeter, the main entrance shall be moved or screened to block the line of sight.
- (c) All exterior doors into inhabited areas shall open outwards.
- (d) Rooms to which mail is delivered or in which mail is handled in inhabited buildings shall be located on the perimeter of the building. Mailroom shall be as far as possible from heavily populated areas of the building and critical infrastructure and shall be sealed to limit migration into building of airborne chemical, biological and radiological agents.
- (e) External roof access shall not be used on new buildings. External roof access for existing buildings, shall be eliminated or secured with locked cages or similar mechanisms.

18.8.5 Structural

- (a) The structural design shall incorporate applicable requirements for minimum standards for force protection from UFC 4-010-01. Conventional construction may be used for the buildings without a specific analysis of blast effects if the specified minimum setback distances are provided. If the setback distances are not provided, an engineer experienced in blast-resistant design shall analyze the building and apply building hardening as necessary to provide an equivalent level of protection from the effects of the applicable explosives’ weights at the achievable standoff distances.
- (b) For all buildings with three stories or more, progressive collapse shall be evaluated in accordance with UFC 4-023-03.
- (c) All building additions shall be designed to be structurally isolated from the existing building. All uninhabited areas of buildings shall be designed to be structurally independent from the inhabited areas or verify through analysis that collapse of the uninhabited portions of the building will not cause collapse of the inhabited areas of the building. As an alternative, design the uninhabited areas of the building to meet the requirements for an inhabited building.

- (d) Building overhangs with inhabited space above them shall not be used.
- (e) All exterior masonry walls shall provide a minimum of 0.05 percent vertical reinforcement with a maximum spacing of 48 inches on center.
- (f) Window and skylight frames, and glazed door frames shall be designed in accordance with the special provisions of UFC 4-010-10, Appendix B, paragraph 3.1.
- (g) Supports for all overhead mounted architectural features and utilities or other fixtures weighing 31 pounds or more shall be designed for a minimum of 0.5 times the component weight in any direction and 1.5 times the component weight in the downward direction.

18.8.6 Mechanical

- (a) Outdoor air intakes must be at least 10 feet above the ground for new buildings and as close as possible to 10 feet above the ground for existing buildings.
- (b) There must be an emergency shutoff switch in the HVAC control system that can immediately shut down air distribution throughout the building.
- (c) Chillers (and all major mechanical equipment) should be located outside the unobstructed space, at least 33 feet from the building. If they are located within the unobstructed spaces and have an enclosure with more than 2 sides, the equipment shall be enclosed on all four sides and the top and shall be lockable. The top surface of the enclosure shall be visible to the casual observer.

18.8.7 Electrical

- (a) The electrical design shall incorporate applicable requirements for minimum standards for force protection from UFC 4-010-01. Specific instructions for the location and protection of electrical equipment are shown in Appendix "B" to the UFC. It is not recommended that electrical equipment be located on the roof as allowed in Appendix "B".

Appendix

Eglin AFB Specific Requirements

Appendix 1 – Eglin Specific General Requirements

A1.1 Dr. Checks

Dr. Checks is the Eglin AFB system of record for capturing and resolving issues related to projects in design. As such, each reviewer shall provide their comments in Dr Checks, not via email, text, phone call etc. This is critical to ensuring design issue resolution. As design projects proceed, back checks of issues during each review must occur to verify issue resolution.

Appendix 2 – Eglin Specific Specification Requirements

No specific requirements.

Appendix 3 – Eglin Specific Site Development Requirements

A3.1 STORM DRAINAGE

A3.1.1 Design Storm Frequency

Provide selected design values to be used in the storm drainage calculations such as runoff coefficient, infiltration rate and rainfall intensity. Rainfall intensity shall be based on the most stringent of regulatory requirements. If no regulatory design storm exists, rainfall intensity shall be based on the 25-year frequency, critical duration rainfall event. Post-construction storm water runoff shall not exceed the calculated pre-construction runoff rate. Storm water quality must be addressed as required by FDEP, NFWFMD, EISA or other regulatory requirements.

A3.1.2 Drainage Design Criteria

- (a) The criteria and procedures are for areas up to one square mile, where only peak discharges are required for design, and ponding is not permitted.
- (b) The design storm shall be based on the 25-year storm frequency with “no ponding”. The designer will check the 100-year event through the proposed system to ensure no flooding or damage occurs.
- (c) Minimum times of concentration (t) of 5 minutes shall be used.
- (d) Manholes and/or junction boxes shall be provided at points of change in conduit grade, size, or horizontal alignment. Distances between points of entry shall not exceed 300 feet for conduits smaller than 30” diameter.
- (e) Pipe discharge velocities must not be less than 2.5fps to provide for adequate pipe cleansing.
- (f) Minimum pipe size shall be 12” for closed drainage systems and 18” for individual culverts, unless unusual or special design considerations warrant using smaller pipe.

- (g) Storm drainage systems shall be constructed in accordance with UFGS Specifications Section 33 40 01. The specifications contain instructions and information that must be considered during design.
- (h) Plastic pipe shall be HDPE double wall. Discharge piping shall be terminated in an elliptical mitered end section with concrete collar or concrete headwall. Provide for energy dissipation as required.

A3.2 ROADS, STREETS AND PARKING AREAS

A3.2.1 Curbs

All flexible pavements within Eglin proper, Duke Field, or the 7th Special Forces cantonment area shall be edged with either a minimum 12”w x 8”d concrete ribbon curb or curb and gutter with 6” tall curb and 24” wide gutter such as an FDOT Type F curb. Curbing for rigid pavements shall be as required for storm water management.

A3.2.2 Parking Spaces

Parking Spaces shall be a minimum 9’ wide x 20’ deep. Parallel parking spaces, where allowed, shall be a minimum 9’ wide x 22’ long. Handicap spaces shall be a minimum of 12’ by 20’. Provide for ramp access from vehicles carrying wheelchair bound individuals and for ramped handicap access. Provide for curbed, grassed islands at the end of rows of 12 spaces.

Appendix 4 – Eglin Specific Survey and Mapping Requirements

- A4.1 All required attribute information shall be entered into geodatabase deliverables per the Air Force Adaptation of the Defense Installation Spatial Data Infrastructure (DISDI) Spatial Data Standard for Facilities, Infrastructure, and Environment (SDSFIE), <https://www.sdsfie.mil/standard>. All geospatial data shall be delivered according to the specifications documented in Chapter 3 of the Eglin GIS User’s Guide. All GIS data shall be free of geometrical and topological errors such as slivers, undershoots, overshoots dangles, overlaps, kickbacks, etc. All geodatabase deliverables shall be formatted to include Z (height) values, even if values were not collected.
- A4.2 Geodatabase feature data sets shall have properly configured precision settings to maintain data integrity and spatial accuracy in accordance with specified precisions outlined in the Eglin Air Force Base Instruction 32-1004 and associated Eglin GIS User’s Guide. Data shall be within spatial domain extents. Spatial domain precision values shall be set to preserve the accuracy of all geodatabase feature classes (x, y, and z values) within a feature dataset. All geodatabase features must be able to be loaded into the Eglin Enterprise Spatial Database environment (ArcSDE) without errors resulting from poor data/schema integrity. All analog or CAD to GIS conversion of data shall result in data that is geo-referenced to the most accurate supporting data available.
- A4.3 The A-E shall provide a quality control (QC) report that must state whether all inconsistencies in the data generated were corrected, or it must detail the remaining errors by case. The A-E shall collect FGDC (Federal Geographic Data Committee) complaint metadata on all digital geospatial data created under this contract in accordance with the latest Air Force Adaptation of the aforementioned SDSFIE. All metadata deliverables shall reside within the geodatabase using the current ArcGIS metadata template. Information on the FGDC’s “Content Standards

for Digital Geospatial Metadata” (CSDGM) is available from the Internet site at:
<https://www.fgdc.gov/metadata/>.

- A4.4 Process steps for each feature class shall be exceedingly detailed and thorough. All GIS data submitted are Air Force Property and shall be treated as “Controlled Unclassified Information (CUI)” and protected against unauthorized transmission IAW DoDI 5210.83 and AFI 31-401. Once data is reviewed, approved, and formally accepted by the Government, all data residing on the A-E’s system, whether provided by the Government or created by the A-E, shall be returned to the Government and removed from the A-E system, or destroyed.
- A4.5 If field data collection is required, the A-E shall provide survey grade GPS data at an accuracy level of +/-3cm. where appropriate (as determined by the Government), and all other collection at a resource grade accuracy level of +/- 1M. The A-E shall capture network features (utility lines, water networks, etc.) at a minimum of once every 50 ft. Each turn or bend in a utility must also be adequately captured.
- A4.6 All .mxd (ESRI ArcGIS Map Document) files shall store “relative paths” to all geodatabase data to maintain map integrity and data connectivity. Supporting geodatabases shall be stored in a “database” folder parallel to the .mxd files thus providing a stand-alone deliverable. Feature symbology shall be standardized for all maps and shall follow standards set by Eglin GeoIntegration Office (GIO). All maps submitted are Air Force property and shall be treated as “Controlled Unclassified Information (CUI)” and protected against unauthorized transmission IAW DoDI 5210.83 and AFI 31-401. Once maps are reviewed, approved, and formally accepted by the Government, all AF maps residing on the A-E’s system, whether provided by the Government or created by the A-E, shall be returned to the Government and removed from the A-E system, or destroyed.
- A4.7 AutoCAD segmented features shall be made continuous and free of self-overlapping sections. No additional attribute fields shall be created unless approved by Eglin GIO. All AutoCAD annotation shall be converted into attributes in the newly created feature class it describes using SDSFIE guidance. All data deliverables (FGDB and raster) referenced by the .mxd files shall exist in one SDSFIE compliant geodatabase in accordance with the latest version of the Air Force Adaptation.
- A4.8 The A-E shall also provide CAD mapping deliverables that meet the following requirements: All CAD data shall be set to the Installation’s projection and coordinate system so as to properly overlay over projected spatial data in ESRI’s ArcGIS Desktop software. Segmented lines and arcs are to be made continuous, thus decreasing files size and increasing efficiency within the CAD platform. If relevant to the project, building numbers, street addresses, street names, and new facilities are to be added to the map. If necessary, layers can be “X-refed” to the main base map file to increase efficiency. All files and layers shall be labeled in accordance with the latest Air Force adaptation of SDSFIE. All geodetic data shall be collected using the WGS84 reference system using geographic coordinates (lat/long) or projected to the appropriate zone of the UTM grid system using feet or metric coordinate units per the Eglin GIS User’s Guide. Special requirements for handling classified map data, if applicable, will be addressed elsewhere in this SOW.

Appendix 5 – Eglin Specific Geotechnical Requirements

No specific requirements.

Appendix 6 – Eglin Specific Landscaping, Irrigation, Planting and Turfing Requirements

Refer to appropriate Architectural Compatibility Guide.

- A6.1 Irrigation
- Permanent irrigation systems are not permitted on Eglin Air Force Base.
- A6.2 Landscape beds and shrubbery
- Shrubbery shall not be installed on new Eglin facilities. Sod shall be drought resistant, and sod shall be live when laid.
- A6.3 Trees
- Trees are not to be installed unless specifically approved by Eglin CE. When approved, species shall be as indicated in the Eglin Architectural Compatibility Plan.

Appendix 7 – Eglin Specific Water, Wastewater and Environmental Protection Requirements

- A7.1 The design of all domestic water and wastewater systems shall be in accordance with the current ASUS design requirements. Should any requirements listed below conflict with ASUS standards, ASUS standards shall govern.
- A7.2 The contracting officer and Installation Radiation Safety Officer (IRSO) must be notified whenever the use of radioactive material (RAM) or radiation producing devices (RPD) is anticipated on Eglin AFB. Contractors bringing RAM or RPDs onto Eglin main base must have a Nuclear Regulatory Commission (NRC) license, or an Agreement State license with current NRC Form 241, authorizing possession, use, storage, and transfer of RAM on the installation. For Eglin range operations, must hold a valid state license for RAM or have currently paid reciprocity to state of Florida (in the case of an out-of-state license). RPDs/x-rays are regulated off base by the state of Florida although this authority has been delegated to 96 AMDS/SGPB for on-base operations. Written approval from the IRSO is also required. Additionally, the contractor must provide information on location, description of use and duration. Specific information describing the type/isotope, quantity/activity and intensity of radiation should be included. The contractor must also provide a Health and safety Plan for the use of RAM on Eglin.

Appendix 8 – Eglin Specific Architectural Requirements

- A8.1 Functional Criteria
- Eglin Air Force Base Architectural Compatibility Plan shall be used as a guide for specific criteria as it applies to all facilities on Eglin AFB. The 7 SFG(A) Architectural Compatibility Plan shall be used for facilities within the 7 SFG(A) Cantonment Area and all facilities provided exclusively for 7 SFG(A) personnel use.
- A.8.2 Roofs. IAW UFC 3-110-03 (1-8.6) incorporate fall protection control measures in the design of roofs for inspection and maintenance of roof, equipment, etc.
- A.8.2.1 New Construction
- Low Sloped Roofs. Incorporate a parapet or guard rail system around the perimeter of

the roof and a roof access hatch

Pitched Roofs. Design must include certified and labeled anchorages IAW OSHA 29 CFR 1910.28 and American National Standards Institute (ANSI) Fall Protection Series Z359 Codes 1-14. Plan shall provide a detail of fall protection anchor points for roof and equipment maintenance and inspections. Roof Plan View shall indicate location of anchor points. Fall protection system design and engineering shall be coordinated with the building systems in which it is attached to assure sufficient strength is provided for the fall protection system operation and use. 29 CFR § 1926.502(d)(15) requires the anchorages to support 5,000 pounds per employee or as an alternative (d)(15)(i) requires maintaining a factor of safety of at least two to the maximum fall arresting force of the personal fall arrest system. Assume there will always be at minimum 2 employees on the roof. Roof warranty placards shall be mounted adjacent to roof access ladders, hatches, etc. as applicable.

Standing Seam/Metal Roofs. All standing seam/metal roofs shall be designed with permanent anchor points mounted to structural steel. They shall have a post/stem with a single ring attachment and horizontal and/or vertical lifelines of the coated steel type. Locations should be such that at minimum, all surfaces of the roof are within 50' of an anchor point. Anchors bolted below the roof shall be accessible for inspection.

A8.2.2

Modification / Reroofing:

Low Sloped Roofs: Design shall incorporate a parapet or guard rail system around the perimeter of the roof and a roof access hatch when feasible. If not feasible, it shall have certified and labeled anchorages IAW OSHA 29 CFR 1910.28 and American National Standards Institute (ANSI) Fall Protection Series Z359 Codes 1-14. Plans shall provide a detail of fall protection anchor points for roof and equipment maintenance and inspections. Roof Plan View shall indicate location of anchor points. Fall protection system design and engineering shall be coordinated with the building systems in which it is attached to assure sufficient strength is provided for the fall protection system operation and use. Roof warranty placards shall be mounted adjacent to roof access ladders, hatches, etc. as applicable.

All roofs without a parapet or guardrail system shall be designed with permanent anchor points that have a single ring attachment for use with permanently installed horizontal lifeline. Locations should be such that at a minimum all surfaces of the roof are within 50' of an anchor point.

Anchor points that are mechanically attached to a standing seam should only be used with existing standing seam roofs with a thickness of at least 20 gauge. Anchors bolted below roof shall be accessible for inspection.

Example: Building 561 roof anchors

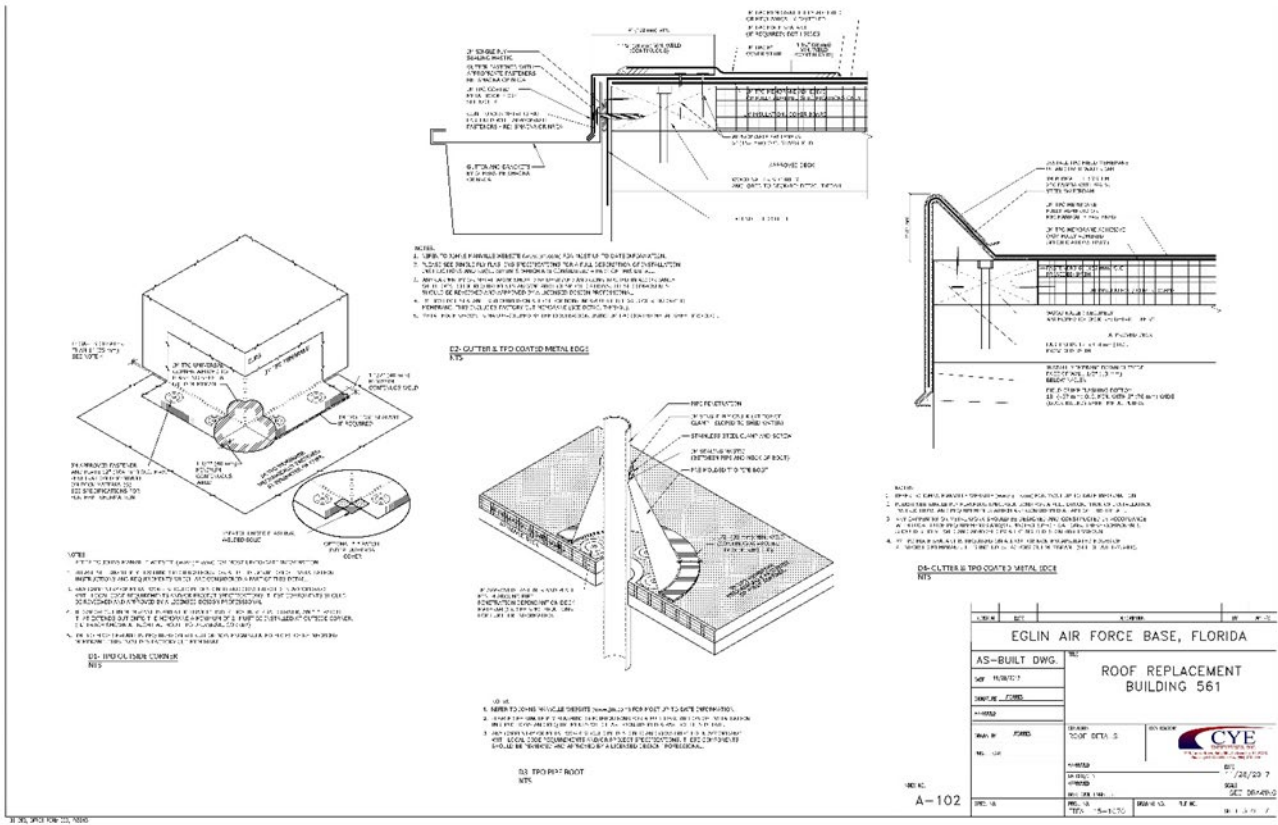

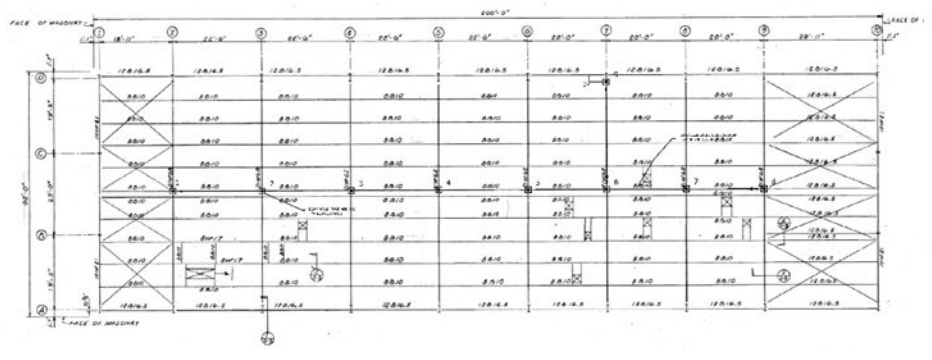

ANCHOR LAYOUT
 SEE 1001

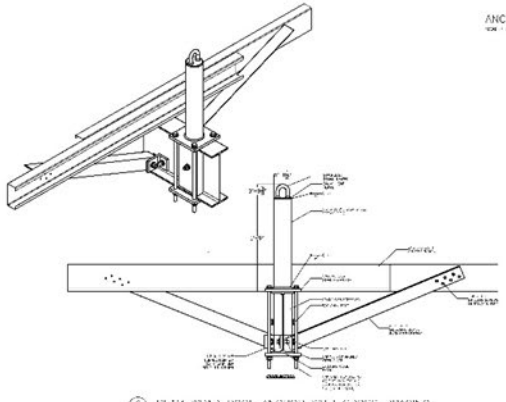

10 AW 101A HIGH ANCHOR WITH CROSS BRACING
 SEE 1001

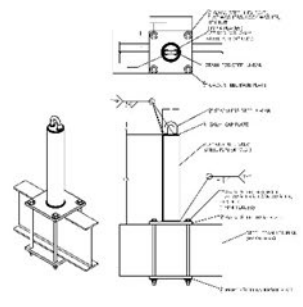

10 AW 101A HIGH ANCHOR
 SEE 1001

DATE	BY	REVISION	BY
EGLIN AIR FORCE BASE, FLORIDA			
AS-BUILT DWG.		ROOF REPLACEMENT BUILDING 561	
REV	DESCRIPTION	DATE	
01	ISSUED FOR CONSTRUCTION	07/28/2017	
PROJECT			
DRAWN BY		CHECKED BY	
DATE		DATE	
SCALE		SCALE	
SHEET NO.		SHEET TOTAL	
PROJECT NO.		PROJECT NAME	
DRAWN BY		CHECKED BY	
DATE		DATE	
SCALE		SCALE	
SHEET NO.		SHEET TOTAL	
PROJECT NO.		PROJECT NAME	

A-104



DEPARTMENT OF THE AIR FORCE
796 CIVIL ENGINEER SQUADRON
EGLIN AIR FORCE BASE

20 November 2020

MEMORANDUM FOR 96 CEG/CEN

FROM: 796 CES/CEOHS
Locksmith/GSA Hardware Inspector
501 DeLeon St., Ste. 100
Eglin AFB, FL 32542

SUBJECT: Security and Life Safety – Protection of Classified Information
This memorandum supersedes original letter dated 28 Oct 2016.

References: (a) Security Facts News Letter, Issues 29 and 31
(b) FF-L-2890C, Lock Extensions, 22 February 2019
(c) DoDM 5200.01, Volume 3 Enclosure 3, Information Security Program

BACKGROUND:

Federal Specification FF-L-2890 (Pedestrian Door Lock Assembly Preassembled, Panic and Auxiliary Deadbolts) was originally written to identify security/operational requirements for door locking system hardware for use on doors that protect classified areas. For many years, the locking system hardware used on these doors to secure classified areas has not met the fire and life safety requirements of the Authority Having Jurisdiction (AHJs) for occupant egress capability. These specialized locking systems meeting government security requirements provided security only – not fire and life safety.

SOLVING THE PROBLEM:

The specification has been revised over the years to clarify certain areas within the document. Revision B provided for six different Types of devices and that before hardware is submitted to the government for testing, it must meet all the necessary approvals for fire, life safety, emergency egress and the Americans with Disabilities Act (ADA). This means that a FF-L-2890B product approved by GSA will satisfy security, fire, life safety and ADA compliance. Revision C further clarifies the intended use and provides for ten different types of pedestrian door lock extensions for use in secure areas or Sensitive Compartmented Information Facilities (SCIFs) to protect national security information. In short, the specification was updated to delineate *primary doors*, *secondary doors*, *exit only doors* and includes *stand-alone access control* options.

1. A *stand-alone access control lock extension* will come with an access control device that is designed to operate independently of other access control systems.
2. An *integrated access control lock extension* does not come with an *access control device* and will need to be integrated into the existing facilities access control system.
3. All types of pedestrian door devices are right- and left-hand interchangeable.

The following are excerpts, taken directly from FF-L-2890C (Feb 22, 2019), for the purpose of clarification.

APPLICATIONS:

The intended use of the ten Types of Products (all are dependent on the type and swing of the door opening):

1. SCOPE AND CLASSIFICATION

1.1 Scope.

This specification covers lock extensions: pedestrian door preassembled lock (PDPL), pedestrian door lock assembly panic, (PDLAP) and auxiliary deadbolts (ADB) for use with changeable combination locks and strikes. Pedestrian door assemblies and auxiliary deadbolts include designs that meet applicable requirements of the Americans with Disabilities Act (ADA), the Architectural Barriers Act (ABA), Uniform Federal Accessibility Standards (UFAS), the International Building Code (IBC), the National Fire Protection Association (NFPA), and International Fire Code (IFC).

1.1.1 Limited use.

Lock extensions tested and qualified under this specification are to be sold only to the Federal Government, Government contractors specifically authorized to purchase these lock extensions, or other organizations or persons specifically authorized or required by the government to use these lock extensions.

1.3 Application.

Pedestrian Door Preassembled Locks (PDPL) for security and are used on fire labeled and non-labeled doors as the only locking device. Pedestrian Door Lock Assemblies Panic (PDLAP) are for security and is used in applications with assembly occupancies. Auxiliary Door Deadbolts (ADB) are used for security.

1.5 Classification descriptions.

1.5.1 Primary Entrance Lock Extensions (complete with FF-L-2740B).

Type I – PDPL complete with integrated mechanical access control lock or electronic access control system (i.e., keypad) with a minimum 4-digit combination for use in non-automated uncontrolled (stand-alone) single door applications, FF-L-2740 electromechanical combination lock and ADA compliant one-function egress mechanism.

Type II – PDPL with integrated, fail secure, electric release capability for use with existing automated building access control systems, FF-L-2740 electromechanical combination lock and ADA compliant one-function egress mechanism.

Type III – PDLAP complete with integrated mechanical access control lock or electronic access control system (i.e., keypad) with a minimum 4-digit combination for use in non-automated uncontrolled (stand-alone) single door applications, FF-L-2740 electromechanical combination lock and fire rated panic hardware.

Type IV – PDLAP with integrated, fail secure, electric release capability for use with existing automated building access control systems, FF-L-2740 electromechanical combination lock and fire rated panic hardware.

Type V – ADB with FF-L-2740 electromechanical combination lock and escape mechanism extension with an automatic life safety device with keyed reset function. It shall use a keyed cylinder, and each Type V ADB shall be furnished with a minimum of two keys. Primary use is limited to secure telecommunications closets where there is no normal pedestrian traffic.

Type VI – ADB with FF-L-2740 electromechanical combination lock and escape mechanism extension with a manually operated life safety device. Primary use is limited to secure telecommunications closets where there is no normal pedestrian traffic.

1.5.2 Secondary Entrance Lock Extensions (with no integrated FF-L-2740).

Type VII – PDPL with integrated, fail secure, electric release capability for use with existing automated building access control systems, internal deadbolt with thumb turn and ADA compliant one-function egress mechanism for secondary doors.

Type VIII - PDLAP with integrated, fail secure, electric release capability for use with existing automated building access control systems, internal deadbolt with thumb turn and ADA compliant, fire rated panic hardware for secondary doors.

1.5.3 Secondary Egress/Exit only Lock Extensions (with no integrated FF-L-2740).

Type IX – PDPL permanently dead-bolted, ADA compliant one function egress for use on egress only secondary doors.

Type X – PDLAP, permanently dead-bolted, ADA compliant complete with fire rated panic hardware for use on exit only secondary doors.

The qualified products list (QPL) for FF-L-2890C devices, dated September 2018, lists products made by Sargent and Greenleaf (S&G), Lockmasters Inc. and KABA-Mas that meet the requirements described in 1.5.1 thru 1.5.2 above. Devices described in 1.5.3 are solely for Exit Only use. All products are available through the respective manufacturer or authorized retailer per the Limited Use clause.

The chart below provides a guide to the proper application.

Door Application	Door Swing	Interior Hardware	Access Control?	FF-L-2740 Combination Lock Included	Door Extension Type
Primary	In/Out	Lever Handle	Stand Alone	Yes	Type I
		Lever Handle	Integrated	Yes	Type II
	Out	Panic Device	Stand Alone	Yes	Type III
		Panic Device	Integrated	Yes	Type IV
Secondary	In/Out	Lever Handle	Integrated	No	Type VII [1][2]
	Out	Panic Device	Integrated	No	Type VIII [1][2]
Exit Only	In/Out	Lever Handle	N/A	No	Type IX [1]
	Out	Panic Device	N/A	No	Type X [1]
No Occupancy	In/Out	Escape Knob	N/A	Yes	Type V & VI

[1] Secondary and Exit Only doors, Types VII - X, are not equipped with a FF-L-2740 electromechanical combination lock incorporated.

[2] Secondary doors are intended for integration with the facility access control system.

Below are pictorial representations of FF-L-2890C Type devices by Manufacturer (*best practice use*):

Type II: Use with ACS (in-swing or out-swing doors)



Types IV: Use with ACS (outswing doors)



Type V: Use without ACS (In- or Out-swing Secure Telecom. Closets)



Type VI: Use without ACS (In- or Out-swing Secure Telecom. Closets)

A secondary lockset is required with this device (not pictured)

KABA-Mas



Type VII: Use with ACS (In- or Out-swing secondary entry) without dial combo lock
S&G Lockmasters



Type VIII: Use with ACS (Out-swing secondary entry) without dial combo lock
S&G



Type IX: Exit Only (In or Out-swing doors)
S&G Lockmasters

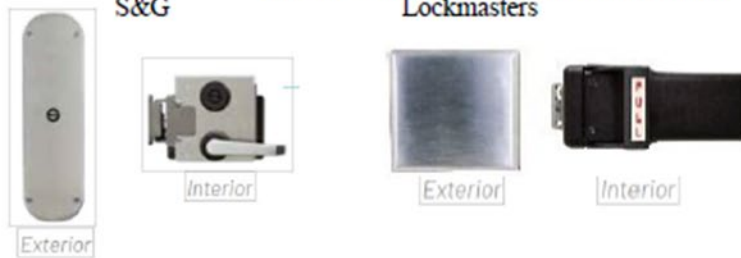

Type X: Exit Only (Out-swing doors)
S&G Lockmasters



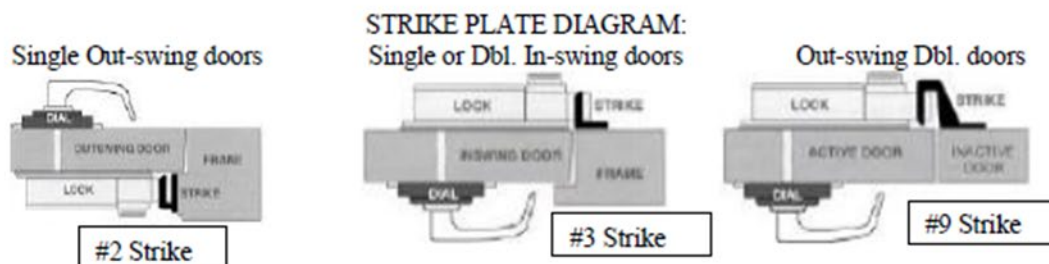

SPECIAL CONSIDERATIONS:

Secure rooms that require "Out-swing Double Door Unit" configuration - In all instances, the Architect, engineer or door and hardware supplier must provide for a "Removable Mullion Post" between the two doors. This specific feature provides the best application for FF-L-2890 devices (regardless of Type). Example: Active leaf will use Type II or IV device (with #2 Strike) and the in-active leaf will use Type X device (with #2 Strike). Consult AHJ and GSA Hardware Inspector for appropriate use per NFPA guidance.

Although FF-L-2890C Type I and III products (with stand-alone access control features) mentioned above are approved for use, we strongly discourage their use because they do not afford an appropriate measure of security due to the potential risk of compromised keypad access code, when the primary dial combination lock is in the Open/Unlocked position.

MOVING FORWARD:

All new construction and renovation projects, since 2015, have been required to use Federal Specification FF-L-2890 when designing spaces intended to protect classified information.

Always consult the AHJ (local Fire Marshall) and GSA Hardware Inspector if there are questions regarding proper use or configuration of a particular device.

For additional information contact the OPR below.

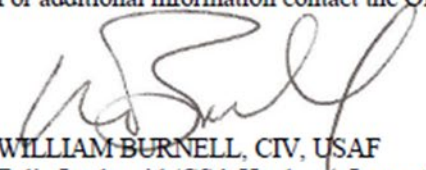
WILLIAM BURNELL, CTV, USAF
Eglin Locksmith/GSA Hardware Inspector
796 CES/CEOHS
Eglin AFB, FL
DSN: 872-1766
Comm.: (850)882-1766

Appendix 9 – Eglin Specific Structural Requirements

No specific requirements.

Appendix 10 – Eglin Specific Plumbing Requirements

A10.1 TECHNICAL REQUIREMENTS

A10.1.1 General Considerations

- (a) All Backflow Prevention Assemblies shall be installed between 1 and 5 feet above finished floor. Any assemblies over 5' shall have a permanent ladder and work platform installed for safe accessibility.
- (b) AFI 32-1067 AWWA manual M-14 requires without exception all backflow prevention assemblies to be tested by a certified backflow prevention tester with a current state certification for backflow testing immediately after installation, when put into service, when taken out of service, when cleaned or repaired, when maintenance or repair is done upstream of the backflow prevention assembly and annually.
- (c) Backflow preventers shall be field tested before connection to potable water supply. All double wye and combination wye fittings are prohibited for horizontal-to-horizontal drainage connections. UPC 706.1A
- (d) UPC sanitary drainage 704.2 and figure 704.2A Double combo wyes, wyes, double sanitary tees, double sanitary crosses are prohibited for back-to-back and side to side trap arm connections at the same level. Use an approved double fixture fitting per UPC.
- (e) Installed faucets will be manually hand operated or maintenance free touchless operated. Maintenance free will utilize a hydro generator or similar system.
- (f) All drain and vent mechanical couplings use to join different materials shall be made with approved shielded couplings designed for resistance to heavy earth loads and shear forces, while providing improved pipe alignment. These couplings shall be manufactured to meet the material requirements of: CSA B602 - mechanical couplings for drain, waste, vent pipe and sewer pipe ASTM D 5926 - Standard specification for poly vinyl chloride (PVC) gaskets for drain, waste, and vent (DWV), sewer, sanitary, and storm plumbing systems ASTM C 1173 - Standard specification for flexible transition couplings for underground piping systems. Clamps Manufactured to the requirements of CSA B602 Clamp Housing- 301 Stainless Steel Clamp Band - 301 Stainless Steel Clamp Screw - 305 Stainless Steel Shear Ring .012" Thick, 300 Series Stainless Steel
- (g) All reduced pressure backflow prevention assemblies shall have an approved airgap fitting and drain piped to a floor drain.

- (h) AFI 32-1067 shall be listed as a reference to all projects with any plumbing, fire suppression, backflow prevention, water treatment, waste water treatment, septic or liquid fuels.

Appendix 11 – Eglin Specific HVAC Requirements, Including DDC

A11.1 TECHNICAL REQUIREMENTS

A11.1.1 General Considerations

- (a) Coordinate space requirements, foundations, supports, duct and pipe routing, electrical service, etc., for mechanical items with architectural, structural, and electrical design elements. Coordinate exterior mechanical distribution systems with design elements handling other exterior utility designs and site work.
- (b) Standard or “packaged” equipment shall be used to the greatest extent possible to simplify specifying, purchasing, installation, and maintenance of equipment. All equipment including AHU’s, chillers, boilers, pumps, fans, VAV boxes, etc shall have individual marks and scheduled individually. Diffusers, grilles, and registers can be collectively scheduled.
- (c) For all projects, use UFC 3-410-01FA and the International Mechanical Code (IMC) for HVAC design.
- (d) All exterior unit pad will have chamfering as shown:

	UNIVERSITY OF PENNSYLVANIA	MASTER DETAIL	TITLE CONCRETE HOUSEKEEPING PAD DETAIL	DATE 08-01-12	REV DATE	FILE NO.
	FACILITIES SERVICES 3101 WALNUT STREET PHILADELPHIA, PENNA. 19104-6289					

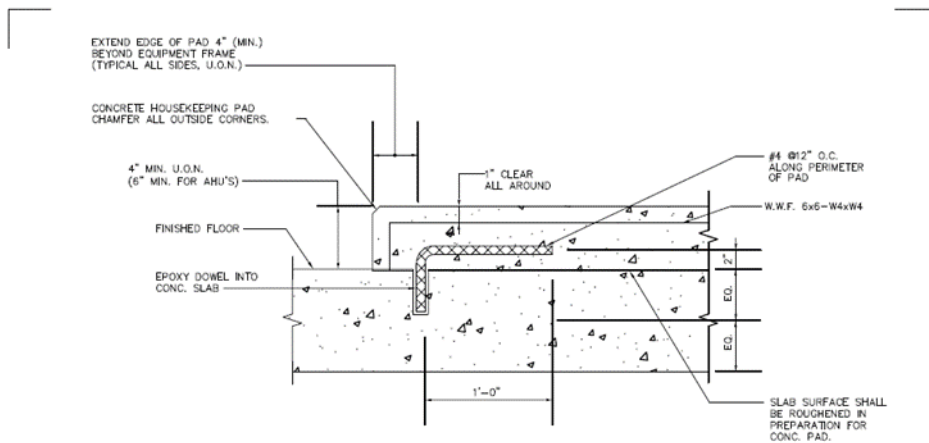

CONSTRUCTION NOTES:
 1. PAD DIMENSIONS AND ANCHOR BOLT SIZES TO SUIT EQUIPMENT.

DESIGN NOTES:
 1. CONSULT WITH THE STRUCTURAL ENGINEER TO DETERMINE IF A THICKENED FLOOR SLAB UNDER BASE IS REQUIRED.
 2. SLAB SURFACE PREPARATION FOR PAD DETERMINED BY WHETHER NEW OR EXISTING.



CONCRETE HOUSEKEEPING PAD DETAIL

SCALE: NTS

A11.1.2 HVAC Design Consideration

- (a) Design Temperatures
 - (1) Indoor design temperatures shall be in accordance with UFC 3-410-01FA.
 - (2) Outdoor design conditions shall be in accordance with UFC 3-400-02.
 - (3) All HVAC loads will be calculated using either Carrier Hourly Analysis Program (HAP), Trane Air Conditioning Economics (TRACE), or a program approved by Eglin Air Force Base. Computer printouts (program input data as well as output results) shall be submitted.
- (b) Noise Control. All noise control design work shall be in accordance with UFC 3-450-01. The designer shall be responsible for ensuring that noise levels in the facility are less than the maximum noise levels recommended in UFC 3-450-01.
- (c) Selection of HVAC Systems. UFC 3-400-01 and ASHRAE 90.1 shall be used in the selection and efficiencies of the HVAC system. Mandatory and prescriptive requirements must be met unless an energy budget analysis is performed to prove the selected system is the most efficient and cost effective over the life of the facility. The user's request for a specific type of equipment shall be honored if possible or feasible.
- (d) Energy Saving Controls and Heat Recovery Devices. Ensure UFC 3-400-01 and ASHRAE 90.1 compliance.
- (e) Water Chillers
 - (1) Chillers greater than 200 tons shall be centrifugal, helical rotary screw type or as approved by Eglin Air Force Base. Centrifugal machines of less than 200 tons capacity may be used at the discretion of the designer or at the request of the user. Chiller compressor working parts shall not be materials other than metal. Refrigerant used must be approved by Eglin AFB.
 - (2) For loads greater than 400 tons, an Energy Cost Budget Study in accordance UFC 3-400-01 and a Life-Cycle Cost Study shall be made to determine whether two or three machines may be more economical than a single machine. In no case, where only personnel comfort is involved, shall considerations be given to a standby machine. Similarly, stand-by chilled water and condensing water pumps are not authorized for personnel comfort applications. Exception to this policy may be granted in accordance with UFC 3-410-01FA. For an installation of more than one chiller, provide a chiller plant controller from the chiller manufacturer to control the chillers to meet the building load in the most efficient mode.
 - (3) Humid Areas. The following criteria shall also be applied to humid areas as defined in UFC 3-410-01FA.
- (f) Air Handling Systems

- (1) Central station type package air handling units complete with filters, coils, and fan section will be utilized where commercially available. Size and number of package units will dependent upon availability and design considerations. AHUs shall not be stacked or installed in any unusual fashion that is not detailed in the manufacturer's standard literature.
- (2) Central station built-up systems comprised of filters, coils, and fan will be installed where system requirements cannot be satisfied with the factory-assembled package equipment. Maximum capacity for the built-up systems will be limited to 60,000 cfm. Total system demands more than 60,000 cfm will utilize multiple systems.
- (3) Package air handling units will normally be located at floor level with adequate clearance for maintenance, test procedures, and equipment removal. Locations above ceilings, above mechanical equipment, suspended 6 feet or more above the floor, or on the roof are undesirable and should be avoided where possible. Adequate height shall be provided in the form of base rails and service pads for proper trap installation.
- (4) Unless noted otherwise, all AHUs in a chilled water system serving a single zone will be furnished with variable frequency drives to vary the airflow to the space. The chilled water coil leaving air temperature will be held constant at a temperature of 55° F or less. A reheat coil shall be furnished downstream of the chilled water coil to prevent overcooling of the space. All ventilation airflow rates shall be ensured.
- (5) All louvers shall be extruded aluminum type with colors to match the architectural scheme or as noted.
- (6) All diffusers, registers, and grilles shall be louvered face aluminum type. Diffusers in exposed round ductwork in shop areas shall be industrial type drum louvers unless otherwise noted.
- (7) Humid Areas. Reference the UFC 3-410-01FA for additional requirements for humid areas.
- (8) Condensate drains shall be rigid metal piping.
- (g) Water Coils. Water cooling coils shall be certified in accordance with ARI STD 410. In lieu of ARI certification, the manufacturer shall submit a written certification from a nationally recognized independent testing firm to verify coil performance when testing in accordance with ARI STD 410 testing procedures.
- (h) Fire Protection. The current requirements of UFC 3-600-01, HFPA 90A and 90B shall be incorporated in all heating and air conditioning system designs. Corridors shall not be used as supply, return or exhaust air plenums.
- (i) Duct Work. Ductwork shall be designed in accordance with applicable SMACNA standards and ASHRAE recommendations. Fibrous glass ductwork shall not be used. Ductwork in shops and exposed areas other than mechanical rooms shall be double walled round (unless otherwise noted). Concealed ductwork shall be externally insulated rectangular (unless noted otherwise). Unless noted, ductwork shall be

designed for .08” s.p. drop per 100 equivalent feet of duct for low pressure (2” or less pressure class – SMACNA) supply duct, .15” s.p. drop per 100 equivalent feet of duct for medium pressure (>2” to 6” pressure class – SMACNA) supply duct, .30” s.p. drop per 100 equivalent feet of duct for high pressure (higher than 6” pressure class – SMACNA) supply duct and .05” s.p. drop per 100 equivalent feet of duct for return duct. Use 45 degree takeoffs in lieu of air scoops. Flexible duct type is described in the guide specifications and length is limited to 5 feet.

(j) Ventilation.

Equipment Rooms. Mechanical ventilation shall be provided to limit air temperature rise to 10° F in unoccupied equipment rooms. Normally occupied areas shall be spot cooled as required. Control rooms on central plants shall be air conditioned. Some equipment room such as control, electrical switch gear, or computer rooms, even though they are unoccupied, will require mechanical cooling and 100 percent backup where economically justified or required by design criteria.

(k) Heating

(1) Outside Design Considerations. Outside heating design conditions for Air Force installations are listed in UFC 3-400-02.

(2) Inside design conditions. Unless stated otherwise, the inside design temperatures shall be determined as follows:

70° F Living and administrative areas (inactive employment)

55-65° F Working Areas (active employment)

40° F Storage areas to prevent freezing.

(3) Boilers. Boilers shall be designed, constructed, tested, and installed in accordance with ASME Boiler and Pressure Vessel Code and UFC 3-410. Design pressures shall be 15 psig or less for steam boilers and 50 psig or less for hot water boilers. Boiler trim shall include safety valves, stop valves, water column, blow-off valves, piping and tank, low water cutoff, flame safety systems, and control panel.

(4) Fuel Oil Burning Equipment and Fuel Oil Storage Tanks. This equipment and tanks shall be in accordance with NFPA Pamphlets 31 and 54 respectively. All underground fuel oil tanks shall be double wall with leak detection systems. A monitoring well system shall be provided if the fuel oil tank is in groundwater.

(5) Gas-Firing Equipment. This equipment shall be in accordance with NFPA Pamphlet 54 and the International Fuel Gas Code.

(l) Piping, Valves and Fittings

(1) Refrigerant Piping. This shall be designed in accordance with ASHRAE Handbooks. Special care in designing suction lines shall be taken to ensure oil

return and to prevent liquid carry-over to the compressor. Where an optional refrigeration piping is allowed, design of piping for all options shall be provided. Hot gas discharge lines shall be designed to ensure oil return. Oil separators shall be provided as required.

(2) Water Distribution Piping.

- (a) Balancing at every point where balancing is required, a flow sensor plus a balancing valve (or a combination units) shall be specified and shown on the plans. The required length of straight pipe before and after the flow sensor shall be clearly shown on the plans.
- (b) Water velocity in medium and small diameter water piping generally shall not exceed 8 feet per second and shall be sized for friction loss not to exceed 4 feet per 100 feet.
- (c) An air separator and expansion tank shall be installed in the main line of all systems.
- (d) For maintenance purposes, isolation valves and unions or flanges shall always be used for isolating equipment from the system.

(m) Chilled and Dual Temperature Water Distribution Systems. The contract drawings shall show the general arrangement of piping, sizes, grades, thrust block, and other details. Analysis shall be made to determine the most economical thickness of insulation for the supply and return lines. The system shall generally be composed of factory fabricated pre-insulated conduit insulation.

- (1) Thermal expansion. Thermal expansion must be considered and accounted for in straight runs of high temperature piping. All lines above ambient temperature must be considered, and calculations for lines above 160°F must be included in the design analysis. Allowable stress ranges are given in ANSI B31.1.
- (2) Anchors. Anchors shall be required where there is a change in direction, diameter, or wall thickness of a pipeline that may cause undesired movement, loads, or stress and whenever buckling of the pipe may occur. For buried piping, no credit may be taken for resisting friction between the pipe and the soil since full development of this force does not occur when line movement is prevented. Anchors may be concrete or piling type.

(n) Mechanical equipment spaces. Mechanical equipment sized from three manufacturers, piping, and accessories in boiler and equipment rooms shall be drawn to scale. Adequate space must be provided for maintenance, operation, and replacement of equipment, piping, and accessories.

(o) Equipment schedules. Equipment schedules are required for all HVAC equipment. The schedule shall be presented in tabular form.

(p) Control. The designer shall contact the base to ensure the new controls are equal to or can seamlessly interface with the existing Direct Digital Control (DDC) system.

A11.1.3

DDC System Requirements

- (a) Provide building level supervisory controllers based on Eglin's existing Niagara 4.0 version matching the current Niagara framework of our DDC Enterprise Network Server (ENS). The building level supervisory controllers shall include point- 2-point (P2P), Secure Socket Layer SSL, Web server and embedded WorkBench (WB). All control devices shall be programmable directly from The Niagara 4 Workbench embedded toolset. The use of configurable or programmable controllers that require additional software tools or tools that require a specific Niagara 4 license brand to operate for post-installation maintenance shall not be acceptable. The building level supervisory controllers shall contain all building logic and graphics and local controller backups. JACE's shall be installed in the mechanical room.
- (b) All graphics and points shall be duplicated in the existing Niagara 4.0 version 4.8 Framework ENS (Enterprise Network Server) using existing workbench software located in building 696 which shall serve as the Web Server for the system. All trended points shall be transferred via P2P to the server for history trending of points.
- (c) Provide Niagara Workbench software matching the current version of the DDC (ENS) server Niagara Framework software. All Software to be installed by the contractor on a government laptop or desktop provided by the 796 CES. Provide software and USB adapters for each type of DDC field controllers, to include factory installed DDC controllers. This laptop will be used/verified during the training. Laptop will need to be submitted to 96 CEG IT to facilitate required device security scans and uploading of Air Force Network (AFNET) standard desktop configuration (SDC) PRIOR to the contractor uploading any specialty (DDC) software. A minimum of 7 days should be allotted to accomplish this. Once complete, the device will be returned to the contractor for DDC software installation and perform training.
- (d) The system shall allow Civil Engineer (CE) technicians to connect to all controllers with all available software in all modes available from the manufacturer from the Bldg. 696 via the local area network (LAN) to program, backup, download, configure, and perform all functions necessary to maintain the system as if onsite and direct connected to the device.
- (d) All hardware and software administrator level passwords shall be provided to the government to access all levels of all controllers including the new Niagara Framework controllers as well as copies of the system's topology, hardware/software inventory, and configuration. The password shall allow complete access to everything the manufacture has access to. Leave the default factory Platform Username and Password.
- (e) All field controllers shall use Bacnet **IP** protocol. Install Field Controller backup software in the JACE.
- (f) Provide a LAN drop within three feet of each building level supervisory controller and provide a patch cable between the LAN drop and the building level supervisory controller.
- (g) When the BACnet communication buss leaves and enters the building, use fiber optic cable and provide media converter pairs (i.e. between buildings or out to chillers) and

provide DB testing results.

- (h) The BACnet communication buss shall be daisy chained to the JACE. No additional switches or routers shall be used.

A11.1.3.1 Energy Management Control System (EMCS) and/or Direct Digital Control (DDC) System Requirements for Existing Facility Remodels

Modifications to an existing facility's Control System (CS) **must** be compatible with the current CS in that facility if the new controls are connecting to existing JACE. Whenever possible, the same brand controls should be used. If a new JACE is to be installed, the requirements for New Facilities will apply.

All graphics (including floor plans) must be updated in the existing ENS (Enterprise Network Server) located in building 696 which shall serve as the Web Server for the system, as well as in the JACE.

The system shall allow Civil Engineer (CE) technicians to connect to all controllers with all available software in all modes available by the manufacturer from building 696 via the local area network (LAN) to program, backup, download, configure and perform all functions necessary to maintain the system as if onsite and direct connected to the device.

Provide all Controls software necessary for project; to be loaded onto an AF provided Laptop with current SDC. Provide latest software and USB adapters for each type of DDC field controllers, to include factory installed DDC controllers. (This laptop will be used/verified during the training).

All hardware and software administrator level passwords shall be provided to the government to access all levels of all controllers including the new Niagara Framework controllers as well as copies of the system's topology, hardware/software inventory, and configuration. The password shall allow complete access to everything the manufacturer has access to.

All field controllers shall use Building Automation and Control network (BACnet) IP protocol.

The BACnet communication buss shall be daisy chained to the JACE. No additional switches or routers shall be used. Ensure not to damage/cut existing Buss Line for the remainder of the facility.

A11.1.3.2 Energy Management Control System (EMCS) and/or Direct Digital Control (DDC) System Graphics Requirements

Graphics shall be in the existing ENS (Enterprise Network Server) located in building 696 which shall serve as the Web Server for the system.

Include date and time on all graphic screens.

Main Map Graphic- This screen will have a list and link to all the buildings on the entire Eglin complex.

Building Graphic- This screen will have a third graphic of the front of the building and a building number. The following links are required on this page: Back to Main Map, Floor Plans, Alarms, Reports, Schedules, History, and User Service.

Floor Plan Graphic

The floor plan will be 3D with color coded zones, room numbers, and as- built sensor and equipment locations. The following points are required on this page: room temp, room humidity, occupancy status. The following links are required on this page: Back to Building Graphic, All Equipment (Click on sensor or

equipment shown on the floor plan and the link will go to the corresponding equipment).

Typical VAV Table Graphic

The VAV table should include the following info:

Box #, Zone Temp, Set Points (Heat & Cool), SP Source, Flow SP, Flow, Damper position, Heating %, SAT

Typical Equipment Graphic

Include a header with equipment type and number, room numbers and area(s) served.

Include all points on the equipment graphic.

The following points will be animated: fans, dampers, coils, pumps, boilers.

All set points will have the capability of being changed from the graphic.

The following links are required on this page: Back to Floor Plan, provide a hidden link over each point to show an hourly 3-day trend, provide a hidden link over each point to override all outputs. Provide a link to a spread sheet with manufacture and part numbers and warranty dates for all parts on the equipment graphic.

Communication Buss Graphic

Include an as-built wiring diagram of the communication bus between all controllers.

Provide a printed copy of the graphics prior to project training.

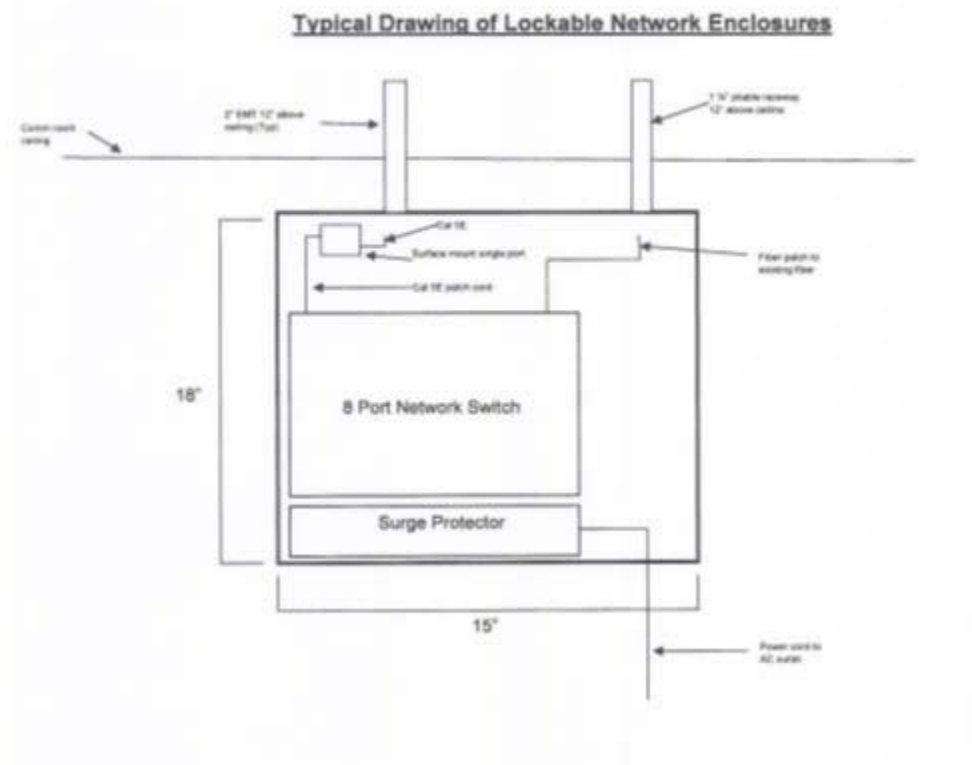

A11.1.3.3 Energy Management Control System Requirements

- (a) Comm Squadron shall Install/Identify 2 fiber strands dedicated for DDC connectivity.
- (b) Install a wall mounted lockable network enclosure (LNE) [with an 8-port switch and a surge protector with back-up power – **provided by customer**] that is compatible with the existing (if renovation project) EMCS network (see sketch above) in the main communications room.

- (c) Install a 20A/125V duplex receptacle within 3 feet of the LNE for connection of the surge protector. This receptacle shall be connected to the emergency power panel if the building is, or will be, equipped with an emergency generator.
- (d) Install a single port LAN connection inside the LNE and inside each building level supervisory controller.
- (e) Install a 2" EMT conduit from the LNE to a height approximately 12" above the communications room ceiling for connection of the LNE to each building level supervisory controller in the building.
- (f) Install a 1 1/4" pliable raceway from the LNE to a height approximately 12" above the communications room ceiling.
- (g) Install a 1 1/4" pliable raceway from the communications terminated fiber patch panel to approximately 12" above the communications room ceiling.
- (h) Install a 3/4" EMT conduit from each building level supervisory controller to a height approximately 12" above the ceiling of each mechanical room they are installed in. If a ceiling is not installed, install the conduit to the same height that matches the height of the 2" conduit installed from the LNE above the communications room ceiling.
- (i) Install a pull string connecting both 1 1/4" pliable conduits installed in communications room (Install a fiber jumper, provided by customer, from the LNE to the installed fiber patch panel).
- (j) Contractor install a purple Cat 5E cable from the LNE to each building level supervisory controller. If the distance exceeds 100 meters between the LNE and the building level supervisory controller, the building level supervisory controller shall be moved to the main communications room, or fiber w/media converters must be used.
- (k) Provide a fiber jumper, provided by the customer, for the complex node that connects the end building to the backbone network switch.

A11.1.3.4 DDC Training Requirements

A11.1.3.4.1 Provide a qualified instructor (or instructors) with two years minimum field experience with the installation and programming of similar BACnet DDC systems. Orient training to the specific systems installed. Coordinate training times and location with the Contracting Officer and BAS Owner after receiving approval of the training course documentation.

A11.1.3.4.2 Training shall take place at the job site or a nearby Government-furnished location. A training day shall occur during normal working hours, last no longer than 8 hours and include a one-hour break for lunch and two additional 15-minute breaks. The project's approved Controls System Operators Manual shall be used as the training text. The Contractor shall ensure the manuals are submitted, approved, and available to hand out to the trainees before the start of training.

A11.1.3.4.3 Training Documentation - Submit training documentation in the form of a training manual for review 60 days minimum before training. Documentation shall include an agenda for each

training day, objectives, a synopsis of each lesson, and the instructor's background and qualifications. The training documentation can be submitted at the same time as the project's Controls System Operators Manual. One training manual shall be provided for each trainee plus two additional manuals for archival storage at the project site. Two copies of audiovisual materials shall be delivered to the Government for archival storage at the project site, either as part of the printed training manuals or on the same media as that to be used during the training session. If media is submitted it will be filmed in 1080p or greater quality format from a tripod or gimbal.

A11.1.3.4.4 Phase I Training - Fundamentals

The contractor will provide training by factory certified trainer(s) for 3 operating staff members designated by the government. The course shall be selected from the DDC manufactures controls factory training department and be relevant to main components used on this project. The training can be located at the manufacturer's factory school or at a classroom provided by the government. The training session shall be conducted in a classroom environment with complete audio-visual aids provided by the contractor. Provide each trainee a printed 8.5 by 11 inch hard- copy of all visual aids used. Upon completion of the Phase I Training, each trainee should fully understand the project's DDC system fundamentals. The training session shall include the following:

- (a) DDC fundamentals (objects, services, addressing) and how/where they are used on this project
- (b) This project's list of control system components
- (c) This project's list of points and objects
- (d) This project's device and network communication architecture
- (e) This project's sequences of control, and:
 - (i) Alarm capabilities
 - (ii) Trending capabilities
 - (iii) Troubleshooting communication errors
 - (iv) Troubleshooting hardware errors

A11.1.3.4.5 Phase II – operation - Provide Phase II Training shortly after completing Phase I Training. Phase II training shall last one day per Building and be conducted at the DDC system workstation, using one laptop computer with the latest operating system, cpu, and technology as it relates to laptops. Provide software and USB adapters for each type of DDC Field Controllers, to include factory installed DDC Controllers. connected to the DDC system in the field, and at other site locations as necessary. Upon completion of Phase II Training, each trainee should fully understand the project's DDC system operation. The training session shall include the following:

- (a) A walk-through tour of the mechanical system and the installed DDC components (controllers, valves, dampers, surge protection, switches, thermostats, sensors, etc.)
- (b) A discussion of the components and functions at each DDC panel.
- (c) Logging-in and navigating at each operator interface type.
- (d) Using each operator interface to find, read, and write to specific controllers and objects.
- (e) Modifying and downloading control program changes.
- (f) Modifying set points.
- (g) Creating, editing, and viewing trends.
- (h) Creating, editing, and viewing alarms.
- (i) Creating, editing, and viewing operating schedules and schedule objects.

- (j) Backing-up and restoring programming and data bases.
- (k) Modifying graphics text, backgrounds, dynamic data displays, and links to other graphics.
- (l) Creating new graphics and adding new dynamic data displays and links.
- (m) Alarm and Event management.
- (n) Adding and removing network devices



DEPARTMENT OF THE AIR FORCE
 AIR FORCE CIVIL ENGINEER CENTER
 TYNDALL AIR FORCE BASE FLORIDA

18 March 2025

MEMORANDUM FOR RECORD

FROM: AFCEC/CO
 139 Barnes Drive, STE 1
 Tyndall AFB, FL 32403-5319

SUBJECT: HVAC Chiller System Manufacturer Standardization Request

1. This memorandum serves as AFCEC/CO's official communication approving the selection for standard Chiller System(s) respective to the following installations:

Installations:	Unit:	Manufacturer:
Andersen AFB	36 CES	Dunham Bush
Arnold AFB	704 CES	Carrier
Dyess AFB	7 CES	Trane
Eglin AFB	96 CES	Trane
Kirtland AFB	377 CES	Johnson Controls (York _ Quantech)
Lajes Field AFB	765 CES	Mitsubishi
Tinker AFB	72 CES	Trane
Buckley AFB	460 CES	Trane
Homestead AFB	482 CES	Carrier

2. Approval for Manufacturer Standardization: The Air Force Civil Engineer Center Operations Directorate (AFCEC/CO) has reviewed and approved the request submitted by the listed installations. The analyses conducted by each base effectively justify the use of the chosen manufacturer.

3. The comprehensive inventory analysis is to be repeated annually. The purpose of this secondary analysis is to document the installation's progress in standardizing HVAC chiller systems, consider any changes in the decision facts, and confirm no external factors exist that may drive a reconsideration of the approved manufacturer. Should the BCE determine that a change in manufacturer is required, a new Memorandum of Request (MOR) and analysis will be accomplished.

4. Please direct any questions and/or concerns regarding implementation of this guidance to Primary POC: Mona MORSI, DSN 523-6264, Mona.Morsi.1@us.af.mil, Alternate POC: Mr. Day Stephen, DSN 523-6363, stephen.day.1@us.af.mil, or to the AFCEC Reachback Center at AFCEC.RBC@us.af.mil.

THEONY.CLIFFORD
 D.M.1030901459
 CLIFFORD M. THEONY, Colonel, USAF
 Director, Operation

Digitally signed by THEONY.CLIFFORD.M.1030901459
 Date: 2025.03.20 18:59:16 -05'00'

Appendix 12 – Eglin Specific Fire Suppression Requirements

A12.1 TECHNICAL REQUIREMENTS

A12.1.1 General Considerations

- (a) Coordinate space requirements, foundations, supports, pipe routing, electrical services, and the like for mechanical items with architectural, structural, and electrical design elements. Coordinate exterior mechanical distribution systems with design elements handling other exterior utility designs and site work.
- (b) Standard or “packaged” equipment shall be used to the greatest extent possible to simplify specifying, purchasing, installation, and maintenance of equipment.
- (c) UFC 3-600-01, *Fire Protection Engineering for Facilities*, is the primary design manual. This criterion is supplemented by the technical provision hereinafter. In case of conflict, this document governs.
- (d) If a fire pump building or room is included in the project that is to be “fully sprinklered”, this building or room also needs to be sprinklered.

A12.1.2 Fire Suppression System

- (a) Criteria. The use of fire suppression systems shall be governed by the requirements of the UFC 3-600-01, *Fire Protection Engineering for Facilities*. Where systems are required, they shall be designed in accordance with the applicable NFPA standards unless it conflicts with the UFC. In which case, the UFC governs.
- (b) Fire Protection. Fire protection that is cost effective yet provides maximum degree of protection consistent with the type and degree of fire exposure, shall neither be diminished to reduce project costs, nor shall it be set aside for security or other considerations.
- (c) Automatic Systems. Automatic fire suppression systems shall be employed where suitable and cost-effective. Suffocating extinguishers shall not be considered in conjunction with munitions or materials that contain their own oxygen supply.
- (d) Low Maintenance. Automatic fire suppression systems, smoke evacuation systems, and other fire protection systems shall be designed so that their proper operation does not depend upon a high degree of sophisticated maintenance.
- (e) Sprinkler Systems. Sprinkler systems shall be performance-specified by the designer in compliance with UFC 3-600-01, *Fire Protection Engineering for Facilities*, NFPA 13, and this document using the most stringent criteria in case of discrepancy. Preliminary hydraulic calculations shall be provided to ensure that system demand does not exceed available supply. Plans developed shall indicate water densities, hazards, area of operation, water flow test data, and any other data necessary for the construction contractor to design the system. The construction contractor shall use the plans and specifications as a guide for subsequent preparation of detailed drawings which will be coordinated with requirements and options of the work of other trades required for construction of the facility. A note to this effect shall be

placed on the plan. Riser locations shall also be shown on the plans.

- (f) Accessibility Check. Designers shall check each system and its equipment to assure ready accessibility without the use of a ladder and operability of all maintenance points, gages, valves, controls, and signals. Where this cannot be accomplished, engineered safety systems shall be employed in the design to limit the hazards for workers, such as fall protection, hoist systems, and ladders/elevated platforms during maintenance operations. Devices whose operations are critical during emergency conditions shall be prominently located and singularly identified.
- (g) Fire alarm/suppression devices greater than 45' or in an enclosed ceiling that cannot be walked on shall have a catwalk with railings to provide unobstructed access to devices such as sprinkler heads, monitor modules, heat/smoke detectors, and freeze sensors.

A12.1.3 Seismic Protection

All piping, equipment, and utilities shall be protected in accordance with UFC 3-310-03A.

A12.1.4 Fire Suppression Training

- (a) The contactor shall provide the manufacturer's recommended/required level of instruction in all aspects of all installed fire suppression systems. This training shall, at a minimum, result in comprehensive factory training in the operation, maintenance, troubleshooting, diagnostic testing, and modification of the installed fire suppression systems.
- (b) This training shall meet the manufacturer's required level of training and shall ensure the unconditional operation and modification of the installed systems by the trained base technicians. This training shall also meet the manufacturer's requirements for the trained technicians to purchase additional and/or replacement equipment as future requirements mandate. Training shall be provided at the project site and, if required, a classroom on Eglin Air Force Base.
- (c) A detailed training plan shall be submitted and approved prior to scheduling any training. The training plan shall provide, at a minimum, specific intervals for the training blocks, location of training, and a detailed breakdown of exactly what the training shall consist of. Once approved, the contractor shall provide a minimum of 14-day notice of the proposed training date. If media is submitted, it will be filmed in 1080p or greater quality format from a tripod or gimbal.

A12.2 EGLIN SPECIFIC FIRE SUPPRESSION DESIGN REQUIREMENTS

1. Butterfly valves shall not be installed except for 2 1/2" hose valves on test headers. The test header isolation valve shall not be a butterfly valve. 2 1/2" and smaller diameter valves shall be ball valves. 3" and larger valves shall be OS&Y. All valves shall be resilient seated if possible.
2. Exterior post indicator valves shall be locked by CE and shall not be electronically supervised.

3. Exterior backflow preventer control valves shall be locked by CE and shall not be electronically supervised.
4. Concrete splash blocks shall be placed to intercept discharge from all inspector's test and main drain valves.
5. All inspector's tests, axillary drain and main drain valves shall be readily accessible without the use of a ladder, not be installed any higher than 72" from the floor and shall discharge to the exterior of all facilities. All drain piping shall be installed with slope so that they drain completely with no water trapping points or bellies. All inspector's test valves shall be 3-way test and drain valves with the test orifice size designated by NFPA 13.
6. The inspector's test valve shall be installed at the system riser no higher than 60" from the floor and shall be readily accessible. It shall be piped to the outside and provided with a splash block.
7. Hydraulic alarms (water motor gong), retard chamber, retard chamber drain, associated trim, alarm test, alarm line, and alarm check valves shall be installed on all sprinkler systems.
8. Hydraulic design plates and general information signs shall be installed per NFPA and shall be engraved so the marking will be permanent. If there is no fire pump, the forward flow test shall be recorded on the general information sign. General information signs shall be installed at every fire sprinkler system and floor control assembly with the location of the air vent and original main drain test.
9. Fire department connections shall be installed in a readily accessible location between 36" and 48" above finished grade.
10. All alarm valves shall be installed in a readily accessible location between 48" and 60" above finish floor.
11. Install a Model 3200 hinged Knox box without tamper on all facilities.
12. All facility fire alarm systems shall be zoned by device, floor, and area.
13. Sprinkler system piping shall be steel. In addition, Schedule 10 piping shall not be used for any fire suppression /extinguishing system piping. Minimum schedule 40 shall be used.
14. All flow switches shall have a means of testing by water flow to the exterior of the building, including elevator shunt flow switches.
15. Fire Department connection check valves shall be readily accessible for maintenance and have access plates to allow internal inspection. If buried, it shall be in a valve pit in accordance with NFPA 13, 8.16.1.4.2 and Figure A.8.16.1.1.4. with a rock bottom at least 12 inches below the check valve to allow for drainage.
16. Pre-manufactured fire pump houses shall have the entire floor area between the beams filled solid with concrete.
17. Fire hydrants shall be painted in accordance with UFC 3-600-01 and NFPA 291. The paint shall be enamel and color matched as follows; Fire Hydrant Red #MD-43827, Safety Yellow #MD-43828, Safety Orange #MD-43829, Safety Blue #MD-43830, Green #MD- 43831.

18. Antifreeze fire suppression systems shall not be used.
19. All alarm valves shall be installed in readily accessible locations no higher than 5' from the floor to facilitate removal/maintenance.
20. Fire pumps over 2000 RPMs are discouraged. Any FP over 2000 RPM must be proved to the government's satisfaction to be the best choice for the particular application.
21. Rope style tamper or locks shall be used on all normally closed valves per most current UFC 3-600-01.
22. Detector check backflow prevention assemblies are prohibited. Per AFI 32-1067, facilities with a fire suppression system shall have a backflow prevention assembly approved for the hazard with a test header that enables a forward flow test IAW UFC 3-600-01. The test header shall be installed on an exterior wall or in an approved location, outside the mechanical room, that is designed to handle the water discharge during testing. RPZ assembly relief valve drains shall be installed with an approved air gap and the drain shall be sized for the total GPM full dump capacity of the relief valve per manufactures specifications, AWWA Manual M-14, and UFC backflow prevention plumbing code. Under sized drains will flood the room and enable backflow contamination of the potable water.
23. All-thread shall not be used for pipe stands.
24. Power sources for installed heat tape shall be monitored by the fire alarm system IAW NFPA 13 and 72.
25. Fire Water Storage Tanks shall be constructed in the following manner:
 - a. Fire water storage tanks shall be constructed of steel with welded and seamless joints.
 - b. Fire water storage tanks shall use an approved air gap as backflow prevention.
 - c. All fire water storage tank inlet control valves shall be slow closing solenoid valves or controlled by solenoid valves only. Hydraulic valves controlled by pressure are prohibited. The water level sensors that control the fire water storage tank inlet fill valve shall tell the inlet fill valve to open before the low-water level supervisory signal activates and stop the inlet water flow before the high-water level supervisory signal activates IAW NFPA 22 and 72.
 - d. Fire water storage tank inlet control valves shall have a means of manual operation.
 - e. Fire water storage tanks shall have all valves and sensors positioned in a readily accessible location to facilitate removal/maintenance.
 - f. Fire water storage tank fill valves that use an electrical means to operate a control valve shall use separate sensors from the high and low water level alarms to operate the level control valve within the high- and low-level alarms.
 - g. The water level sensors that control the fire water storage inlet fill valve shall be the probe type and have the following functions:

- i. High level alarm, Stop fill, Fill, Low Level alarm, Low Temperature alarm Fault alarm (indicates system trouble). Systems like the waterline controls FTP-50T meets all requirements.
- ii. When two fire suppression water storage tanks are required, there shall be two separate fill/monitoring systems so that each tank can be bypassed for maintenance purposes. This is to be accomplished with 1 switch. The only system to be monitored by the fire alarm system is the one currently in service. When both tanks are in service, the primary tank will be the one monitored. An example of this operation is at Bldg 138.
- h. The water level controller shall tell the inlet fill valve to open before the low water level supervisory signal activates. Start Fill no more than 4 inches below the designated fire service level.
- i. The fill valve shall shut off before the high-water level supervisory signal activates. Stop Fill no more than 4 inches above the designated fire service level.
- j. Low Level Alarm when the water falls 12 inches below the high-level alarm.
- k. High Level Alarm when the water is within 1 inch of the tank overflow.
- l. Water tank Level controllers Incoming power shall have an appropriately sized SPD (Surge Protective Device).
- m. All other types of water level sensors are prohibited on Eglin AFB.
- n. Locate fire suppression water tank fill valves inside pump house or inside of and approved heated and monitored enclosure to prevent freezing. The monitoring shall consist of low temperature sensor and heat strip power monitors Per UFC 3-600-01 and NFPA 72.
- o. All Fire water storage tanks shall have stairways and NOT fixed ladders to comply with DAFMAN 91-203. Stairs shall be provided where access is daily or during each shift for gauging, inspection, regular maintenance or when carrying tools or equipment is normally required and sufficient space is available.
- p. All Fire water storage tanks shall be guarded by standard railings and toeboards on all open sides, except at the entrance of the opening. If there is danger of a person walking straight into the opening, a swinging gate or offset passage shall be used in compliance with DAFMAN 91-203.
- q. All Fire water storage tanks shall have frangible locks installed on entry hatches provided by Eglin alarm shop and have permit required confined space signage located near the stairway entrance and on every entrance to the tank.
- 26. Flow meters installed in fire pump systems shall be piped to either the test header or on a separate return to the fire water storage tank.
- 27. City water by-pass loops shall not be utilized on fire pumps supplied by a non-elevated fire water tank.

28. Fire pump discharges shall be used for fire systems only. They shall not be used on domestic water systems.
29. For buildings that have an emergency generator installed, in addition to all other required systems, at a minimum, the fire system jockey pump shall also be covered by the generator. If, however, a building requires installed emergency power (powering selected circuits) intended to continue limited operations, that power shall operate emergency systems including fire protection features, including fire pumps if present.
30. A spare head of every installed dry type sprinkler shall be placed in a box mounted to the wall near the Alarm Valve riser.
31. A recessed type wrench shall be installed in the spare sprinkler head box if any recessed sprinkler heads are installed.
32. All special tools required to reset fire sprinkler alarms shall be provided.
33. Water or sodium bicarbonate dry chemical fire extinguishers shall not be installed.
34. Fire suppression systems inspector's test valves shall not be mounted any higher than 72" AFF.
35. Install RPZ backflow prevention before fill valve if fire water tank will be used to supply a Foam Fire Suppression system.
36. Isolate any system over 20 heads to permit pressurization of new installation to 200 psi while leaving existing system at working pressure.
37. Under floor detection shall be accomplished through an Air Aspirating System.
38. Please provide a box and a copy of all fire suppression O&Ms in the riser room mounted to a wall. This does not need to be an additional copy to the required copies turned in at the end of the contract.
39. Do not install graphic annunciators.
40. Install Building Transceiver top of panel enclosure no higher than 60" AFF.
41. Install Fire Alarm Control Panel top of panel enclosure no higher than 70" AFF.
42. When pipe thread sealant is used, use a non-petroleum-based product. Oil residuals have been found on heads from the oil separating from the base of the thread sealant.
43. No CPVC shall be used. Not even for transitions into secure vaults. Use grounding per SCIF UFC 4-010-05, paragraph 3-5.8.2 for sprinkler pipe penetrations.
44. All check valves over 2" must have an inspection plate for maintenance and inspection without removing the check valve assembly from the piping system.
45. Mass notification system is NOT required in a remodeled facility unless it is a "primary gathering of 50 or more occupants" per AFCEC.

46. On Foam systems - Please install a 1/2" solution sample point after the first elbow passed the proportioner and before the foam generator. Hard pipe it to a location outside of the foam hazard and high enough off the floor to put a 55-gallon drum under it to catch the flow. Install a valve at the tap and the sample point. Plastic pipe is OK for this installation, we prefer Aquatherm Red pipe.
47. On Foam systems - Please install a 1" diameter schedule 40 steel piping for a solution pressure point at the inlet to the most remote foam generator. Hard pipe it so that it completely drains with no water trapping points to a readily accessible location outside of the foam hazard and high enough off the floor to put a 55-gallon drum under it to facilitate flushing and draining the line. Please install a valve at the tap and one for the pressure gauge at the outlet. Please provide a metal placard with the distance (height) to the inlet of the generator, install it at the base to assist with calculations to figure the pressure at the most remote generator during a foam flow.
48. UFC 3-600-01. For locations subject to freezing, backflow preventers must be in the facility or within a heated enclosure. Provide a low temperature supervisory alarm connected to the facility FACP for heated enclosures. Heat trace must Not be used.
49. Make every attempt to design the project for the backflow prevention assembly to be installed in the facility. Exterior backflow prevention assemblies shall be protected from freezing with an outdoor heated, insulated, enclosed, readily accessible enclosure locked by CE. The heater power and functionality shall be supervised by the facility FACP.
50. All fire suppression systems including all foam systems shall be installed so that they drain completely with no water trapping points or bellies.
51. Non-variable frequency drive jockey pump controllers are prohibited. All jockey pump controllers shall be variable frequency drive. All software and programming shall be provided with training to allow the 796 CES Alarm Shop to be able to maintain and program the controller.
52. The sprinkler system installer must be regularly engaged in the installation of the type and complexity of system specified in the contract documents and must have served in a similar capacity for at least three systems that have performed in the manner intended for a period of not less than 6 months per the Whole Building Design Guide Specification 21 13 13 section 1.4.2.2.
53. All potable water supply to all fire water storage tanks shall be piped to the highest part of the tank with an approved air gap and or reduced pressure principle backflow prevention assembly per AFI 32-1067.
54. Install automatic air vent valves. Piping shall be installed with slope to facilitate air venting. Provide isometric shop drawings with locations of air vents, which are required to be reviewed by the government prior to installation. Install a minimum one-inch diameter air vent connected to the wet fire suppression system at the highest point off of the top of horizontal pipe or off the side of vertical pipe that allows the most air to be purged from the system with a minimum 1" full port valve no higher than 6 feet piped to the outside of the building for every 3,000 square feet of wet fire suppression system protection. Example, a building with 10,000 square feet protected by wet fire suppression systems shall have 10 air vents connected to the fire suppression system at a high point which facilitates the purging of

air remotely spaced from each other and the alarm valve with easily accessible, without the use of a ladder, full port ball valves or test and drain valves piped to the outside. All wet fire suppression systems including shotgun systems shall have a minimum of one inspector's test and one auxiliary drain remotely located from the riser and each other, piped to the outside with an easily accessible, without the use of a ladder, test and drain valve. Gridded systems that are installed with their mains running down low and branch lines going up that are not tied together at the high point trap higher volumes of air. Any gridded system with mains lower than branches protecting more than 2,000 square feet shall be installed by connecting all the branch lines together at the high point and piping an air vent to the outside with a readily accessible full port ball valve or test and drain the same size as the piping. The larger the system, the larger diameter the piping will need to be that connects all the branch lines and is piped to the outside to purge enough air to prevent flow alarm switch failures, nuisance alarms, and microbiologically influenced corrosion, which will greatly accelerate corrosion and shorten the life of the system.

55. All wet fire suppression systems shall be installed in a heated and insulated space.
56. All underground fire suppression piping, including fire pump systems, shall be welded stainless steel or piping that requires butt fusion methods to join the pipe. Service lead-in risers transitioning from underground shall be welded stainless steel from an accessible location outside the building to inside the building and shall be pressure tested at 200 PSI after shipping to ensure no damage accrued from the time it was tested at the factory. All mechanical joints shall be tightened with a calibrated torque wrench to the manufacturer's specifications. No loss of pressure or visible leaks allowed on underground fire pump or fire suppression systems.
57. All floor control assemblies, control valves, drain valves, test valves, manual air vent valves, flow switches, check valves shall be installed no higher than 7 feet from the floor.
58. Before connecting any potable drinking water piping to any fire suppression system, schedule the 796 CES backflow prevention program manager and fire suppression subject matter expert to be present.
59. AFI 32-1067 AWWA manual M-14 requires, without exception, all backflow prevention assemblies to be tested by a certified backflow prevention tester with a current state certification for backflow testing immediately after installation, when put into service, when taken out of service, when cleaned or repaired, and when maintenance or repair is done upstream of the backflow prevention assembly and annually thereafter.
60. During installation, maintenance, or repair upstream of the backflow prevention assembly, keep the inlet shut off valve closed and flush the piping thoroughly upstream before opening the inlet valve. Thoroughly flush the upstream piping of the backflow prevention assembly and the fire suppression system before connecting the piping.
61. For fire pump installations supplied directly from the base potable water main off a potable water tower instead of a non-potable ground level fire water storage tank, backflow prevention assemblies shall be installed upstream of the fire pump. Installing the backflow prevention assembly downstream of the fire pump exposes the back flow assembly to higher pressures than it is rated for, thereby making it unlawful because it is not tested and approved by USCFCCCHR for that application. Installing the backflow prevention assembly upstream of the fire pump also reduces the cost of installation because you can use the fire pump test header as the forward flow test header.

62. All Bypasses around backflow prevention assemblies are prohibited, including detector check bypasses with backflow prevention assemblies. Detector check assembly bypasses are unnecessary and are another point that can fail resulting in contamination of the potable water system. They also require more labor hours to test and maintain. The first check valve of a detector check backflow prevention assembly has a stronger spring that reduces the water pressure more than a backflow prevention assembly with no detector bypass backflow prevention assembly.
63. Air Force Instruction 32-1067, para 3.3.4.6.1. New Fire Suppression Systems. All new fire suppression systems using potable water shall have backflow prevention installed. Install a double check valve backflow preventer on new dry/wet fire suppression systems that use only water as a fire suppressant (with or without fire department [Siamese] connections). Use a reduced pressure type backflow device only where antifreeze, foam, or other hazardous chemicals are added. Use of double check valve assemblies for protection of potable water from antifreeze, foam, or other hazardous chemicals is prohibited by all backflow prevention and plumbing codes.
64. UFC 3-600-01 9-6.3.2. For new or modified working (shop) drawings and calculations must be prepared by an individual that has obtained National Institute for Certification in Engineering Technologies, Automatic Sprinkler Systems, Level III certification or Special Hazards Suppression Systems, Level IV certification, as applicable to the project. The QFPE must review the shop drawings, hydraulic calculations, and material submittals. The shop drawings must bear the Review Stamp of the QFPE prior to submitting the fire extinguishing system shop drawings to the DFPE. All fire suppression valves including all backflow prevention valves shall be reviewed by the QFPE in a material submittal and be verified by a letter signed and dated by the QFPE that all such material is approved before it is installed. Installation of all fire suppression backflow prevention devices and assemblies before they have been approved in a material submittal is prohibited.
65. NFPA 13 16.9.3.2 Listed Indicating Valves. All valves controlling connections to water supplies and to supply pipes to sprinklers shall be listed indicating valves. Outside stem and yoke valves are approved listed indicating valves and are required by Eglin AFB fire department. Fire suppression backflow prevention double check valves and reduced pressure assembly shut off valves also shut off the fire suppression system which means that these shut off valves or control valves are required by the NFPA to be listed indicating valves.
66. All alarm check valves shall have a modern Underwriters' Laboratories (UL)-listing and contain no lead.
67. All sprinkler systems, including floor control assemblies, and any control assembly shall have an original main drain test done before the project is handed over to the shop. NFPA 24 requires a valve status test (main drain test) every time a control valve is closed and re-opened. This also applies to new construction, remodel, repair, and maintenance projects. A General information sign shall be installed per NFPA 13 on all systems and control assemblies.
68. Main drain tests are required by the NFPA and UFC every time all fire suppression control valves are closed and opened, including maintenance or modification.
69. Testing of all fire suppression systems shall include testing how all alarm flow switches perform directly after refilling. Testing shall prove that the alarm flow switch will come in within the 90 second requirement immediately after re-filling of all wet fire suppression

systems. Air venting shall be designed so that enough air will be vented through the air vents to be able to pass this immediate alarm flow switch test after the re-filling of all wet fire suppression systems without having to adjust the retard delay of the flow switch, open any piping or remove any sprinkler heads, caps, or plugs. For this purpose, all floor control assemblies, control assemblies, system control riser, and auxiliary system control assemblies that have alarm flow switches are included in this test and shall be tested in the manor described above. The test shall be performed after the retard delay of the flow switch is set. Adjustment of the delay after this test is prohibited. Adjusting the delay so that it is very short to get the test to pass and then adjusting the delay after the test was passed to avoid nuisance alarms is prohibited. The delay shall be set long enough to avoid pressure surges causing nuisance alarms and pass the 90 second requirement. A picture will be taken of the retard delay at the time of successful test, and the setting will be checked against that picture before and after the project is done.

70. Provide a waterproof document box labeled "Suppression System Documents" located near the Main Riser with one set laminated 12"x18" as-built shop drawings and schematics, copies of all system testing required by NFPA 13 & 24, one set of removable media containing drawings in portable document formats of as-built drawings and schematics, and PDFs of all testing documents.
71. All Fire Suppression air pressure maintenance pumps in a facility shall be monitored by the FACU for a supervisory condition whenever there is an AC power fail.
72. All Fire Suppression pressure maintenance pump controllers shall be monitored by the FACU for a supervisory condition whenever there is an AC power fail or automatic controls are bypassed.
73. All Fire Suppression pressure maintenance pumps in a facility with a Fire pump shall be wired ahead of the main building disconnect at the transformer just like the fire pumps, the only difference is that there will be a service disconnect installed in the proximity of the jockey pump controller.

Appendix 13 – Eglin Specific Other Mechanical Systems and Equipment Requirements

A13.1 SERVICE CONTRACTS

Elevator installations shall not utilize proprietary controllers or remote monitoring.

Appendix 14 – Eglin Specific Electrical / Electronic Requirements (Including Fire Alarms)

A14.1 EGLIN SPECIFIC CRITERIA

The requirements listed below are specific to Eglin Air Force base. Any conflicts between the requirements listed below and those listed above, shall be governed by the Eglin specific requirements below. Exterior electric shall be in accordance with CHELCO requirements. If any of the requirements listed herein conflict with CHELCO requirements, CHELCO shall govern. The CHELCO POC is as follows:

Mr. Chris Eddy
Project Coordinator

Office: (850) 307-1229
Cell: (850) 307-7880
ceddy@chelco.com

NOTE: The contractor should have tested or scheduled the testing of the Exit and Emergency lights around the same timeframe if not already accomplished.

A14.2 ELECTRICAL DESIGN REQUIREMENTS

NOTE: The Electrical Engineer of Record shall review and approve all electrical submittals and shop drawings for compliance with the plans and specifications prior to the submittal comes to the government for approval.

A14.2.1 Electrical designs shall comply with, but not be limited to, all requirements herein this document.

1. All overhead primary conductors shall be aluminum, and all other conductors shall be copper.
2. All electrical design work shall be signed and sealed by a Florida licensed Professional Electrical Engineer.
3. The Engineer of Record and/or Contractor shall obtain and comply with all design criteria from the following website:

http://www.wbdg.org/ccb/browse_cat.php?o=29&c=4

4. The Electrical drawings shall include, but not be limited to the following:
 - a. Electrical General Notes (Applicable to all electrical sheets) (See Below).
 - b. Electrical work notes (with work notes shown on the same sheet that they apply).
 - c. Electrical Legend.
 - d. Electrical Site Plan.
 - e. Electrical Power floor plans.
 - f. Electrical Lighting plans.
 - g. Electrical Signal plans (Fire Alarm, Telephone, Intrusion Detection System & Card Reader Systems)
 - h. Electrical Panelboard schedules.
 - i. Electrical Light Fixtures schedules.
 - j. Light fixture details describing all lighting fixtures within the project. Provide the details and characteristics for all light fixtures as shown in Section "C" Below.
 - k. Provide an Intrusion Detection System riser diagram showing all devices.
 - l. Provide a detailed telephone riser diagram showing all devices.

- m. Provide detailed fire alarm riser diagram showing all devices.
 - n. Provide fire alarm transceiver zone schedule.
 - o. Provide detailed power riser diagram.
 - p. Provide a detailed card reader system riser diagram showing all devices.
 - q. Provide a detailed projector system riser diagram showing all devices.
 - r. Provide a detailed mass notification system riser diagram showing all devices.
 - s. Indicate on the electrical drawings an Air Handling Unit shut down diagram that illustrates how it interfaces with the fire alarm control panel.
 - t. Miscellaneous details and illustrations as required by the U.S. Air Force.
5. Do not specify multi-section panelboards.
6. Electrical Design shall be designed in accordance with the following:
- a. Air Force Instruction AFI 32-1065, Grounding Systems.
 - b. AFI 32-1023 Design and Construction Standards and Execution of Facility Construction Projects.
 - c. AFI 32-1063 Electrical Power Systems
 - d. AFI 21-402 Engineering Drawing System
 - e. Air Force Manual (AFM) 88-9 Electrical Design Lightning and Static Electricity Manual.
 - f. Unified Facilities Criteria (UFC) 4-021-01 Design and O&M Mass Notification Systems.
 - g. UFC 1-200-01 General Building Requirements
 - h. UFC 3-550-01 Design: Exterior Electrical Power Distribution, latest edition.
 - i. UFC 3-500-10 Electrical Engineering, latest edition.
 - j. UFC 3-501-03N Electrical Engineering Preliminary Considerations
 - k. UFC 3-520-01 Interior Electrical Systems, latest edition.
 - l. UFC 3-550-03FA Electrical Power Supply and Distribution, latest edition.
 - m. UFC 3-580-1 Telecommunications Interior Infrastructure Planning and Design

- n. UFC 3-600-01 Design: Fire Protection Engineering for Facilities
 - o. Electrical design shall comply with NFPA 780, Standard for the Installation of Lightning Protection systems, latest edition.
 - p. Design shall comply with NFPA 72.
 - q. Design shall comply with NFPA 70 National Electric Code.
 - r. Engineering Technical Letter, ETL 90-6 Electrical System Grounding, Static Grounding and Lightning Protection
 - s. All lighting requirements shall comply with the latest edition of the Illuminating Engineering Society (IES) handbook unless Air Force design criteria dictates otherwise. If conflicts exist, the more stringent requirement governs.
- 7. Design shall be in accordance with the latest edition of the Life Safety Code.
 - 8. Transfer switches shall be automatic, four pole, and have a bypass option that allows the switch to operate in bypass mode.
 - 9. All electric metallic tubing (EMT) conduit, fittings, couplings, etc. shall be steel compression type.
 - 10. Bushings are required for EMT connectors 1" or greater utilizing multiple conductors #6 AWG wire or smaller.
 - 11. MC and AC type cables shall not be used.
 - 12. All conduits 3" and larger shall be LB-Mogul type "LB fittings" with rollers.
 - 13. Fill all conduit window openings in concrete pads with pea gravel. This applies to transformers, generators, junction cabinets, sectionalizing switches, etc.
 - 14. A coordination study shall be provided with the design.
 - 15. For a system voltage of 440/277V, the Service Entrance Switchboard, Switchgear, or Panelboard shall have the following features specified on the drawings:
 - a. Long Time Pickup
 - b. Long Time Delay
 - c. Short Time Pickup
 - d. Short Time Delay
 - e. Instantaneous
 - f. Ground Fault Pickup (Provide ground fault protection on main circuit breaker and feeder breakers.

- g. Ground Fault Delay.
 - h. Ground Fault protection shall be set at 10% of circuit breaker ampacity.
 - i. Provide ground fault protection on all Feeder Circuit Breakers.
 - j. Items a thru I above apply to all electronic trip type circuit breakers.
16. Thousand ampere interrupt current (KAIC) rating shall be used for all Panelboards and circuit breakers.
 17. Ground rods at the riser pole, service entrance, and fire alarm panel (antenna) shall be ¾” diameter x 60 feet in length. All connections to ground rods shall be exothermic weld.
 18. Split-bolt connectors shall not be used.
 19. The following notes shall be provided on the drawings or in the contract specifications (Designer shall select the pertinent note):
 - a. Provide a combination KW-HR and KW Demand meter. Meter shall include wireless transceiver hardware. The meter and wireless transceiver hardware shall be compatible with Flexnet System which is currently being used by Eglin AFB. Provide a 13-point terminal meter can with voltage and current test switches. For information regarding specifics of meter and wireless transceiver hardware to be utilized, including frequency requirements, contact Maintenance Engineering, Eglin AFB, at (850) 883-4810.
 - b. Specify current transformers (CTs) to be mounted in the upright position within transformer secondary compartment.
 20. Bolt On circuit breakers must be used.
 21. A surge suppressor shall be provided at the main service.
 22. Only non-fuse disconnects shall be used.
 23. Delta-Wye starters not permitted.
 24. Specify maximum horse-power (HP) or full load current (FLA) ratings of non-hermetically sealed motors on the electrical drawings. Do NOT specify motors in (KW). On electrical drawings, show header pointing to all “HVAC” equipment as shown attached “Section B” that describes the electrical characteristics associated with the air conditioning and heating equipment.
 25. Maximum horse-power Run Load Current (RLA) ratings of hermetically sealed motors shall be provided on the electrical drawings.
 26. Electrical sheets shall not indicate any motors being specified in thousand watts (KW) because power factor and efficiency are unknown.
 27. Nominal values for equipment shall not be indicated on the drawings. Indicate only maximum values.

28. Electrical room shall be situated such that it is accessible from the exterior of the building.
29. All primary cable 2,400 volt and above shall be tape shield type Ethylene Propylene Rubber (EPR) with 133% insulation level.
30. All disconnects shall be heavy duty type.
31. Comply with Engineering Technical Letter (ETL) 1110-3-412 (Boring).
32. All power pole cross-arms shall be fiberglass.
33. Provide at least 15 foot clearing on both sides of centerline of overhead power lines when clearing woods, brush, and shrubs.
34. Show ampere values in the panelboard schedule for all equipment.
35. Install a grounding bus bar in the Mechanical Room in proximity to the Main Panelboard. Various facility grounds should connect at this point.
36. All outdoor hardware and equipment being specified within one mile of coastal waters shall be rated for a corrosive environment.
37. Drive Isolation transformers shall be connected to the line side of all variable frequency drives (VFD). Indicate either on the drawings or in the specifications that the motor is to be compatible with the VFD. Note this equipment shall not be an integral part of the VFD.
38. All conductors #1 and small shall be sized using the ampacities in the 60-degree column of Table 310.16 of the National Electric Code. All conductors 1/0 and larger shall be sized using the ampacities in the 75-degree column of Table 310.16 of the latest edition of the National Electric Code.
39. The following verbiage shall be included in the specifications verbatim: In case of ambiguous language, or conflict between different Air Force standards, contract specifications, or contract drawings, the more stringent requirement, criteria, and/or work-effort shall apply and take precedence.
40. The following verbiage shall be included in the specifications verbatim: The contractor shall examine the contract documents and notify the government of any ambiguous language or illustrations to become familiar with these documents. Submission of a bid will be construed as evidence that such examination has been made and later claims for labor, materials, or equipment required for difficulties encountered will not be accepted by the Government.
41. For medium voltage distribution, use junction cabinets or sectionalizer switches instead of manholes. The sectionalizer switch shall be the VISTA-523 type or Cooper-Power type unless otherwise specified by base engineering and maintenance personnel. Base engineering reserves the right to specify which type of equipment to use during the design phase of the project.
42. Primary pole construction on 25KV systems use 18KV polymer lighting arrestors and on 15KV systems, use 10KV polymer arrestors.

43. The following note shall be added to the construction electrical notes verbatim: Any new additional electrical notes required in this contract shall be signed and sealed by a licensed Electrical Engineer. The work shall comply with the latest edition of Eglin AFB Electrical Design requirements.
44. When developing the construction documents, the design Engineer of Record (EOR) shall physically spend the required hours, days, weeks, months, etc. at the job site to thoroughly familiarize himself or herself with existing site conditions that impact the design and construction of the project. The EOR shall have Engineering Technicians and surveying crews as required assisting with this effort. Any information provided by the Government is for informational purposes only. It will be the EOR responsibility to physically verify information in the field. The EOR shall take as many trips as necessary to the job site to comply with the requirements of this paragraph and document. The EOR shall be physically present at all design review meetings and/or conferences. If the EOR is unable to attend the meeting or conference, then he or she shall have an Electrical Engineer with a Professional License physically attending the meeting as his or her representative.
45. If demand factors are used, the EOR shall thoroughly explain how he or she determined the demand factor. Provide the Government with calculations, assumptions, data logs, notes, etc.
46. The design EOR shall indicate on the drawings for all overhead distribution systems the following: specify using insulators and tie aluminum conductors, this is also known as a tie-wire conductor. The overhead conductor shall be wrapped using the appropriate size tie-wire to protect the conductors. Clearly indicate, do not specify, crimp on stirrups (Hot Line Clamp) or crimp connectors for the ground wires because when they go from copper to aluminum, it creates a corrosion problem. Indicate using a parallel bonding clamp, this is a mechanical screw type connection.
47. Direct bury circuits (not in conduit) is not allowed on Eglin AFB. All circuits shall be in conduit. This includes power and control circuits and airfield lighting circuits.
48. All medium voltage conductors shall have no splices.
49. All manholes that are to contain new power distribution cabling shall have a maintenance loop. The distribution wiring shall wrap one time (minimum) around the wall of the manhole.
50. The following note shall be added to the contract documents; The Contractor shall submit to the government, the certification letter indicating that their electrical vehicles trucks etc, have been dielectrically tested, a copy of this letter shall be carried in all trucks prior to performing any work on Eglin AFB.
51. All drawings shall have the attached "Typical Equipment Labeling Detail."
52. All construction/installation practices shall comply with the attached "Typical Equipment Labeling Detail". This labeling shall be placed on panelboards, switchboards, disconnects, variable frequency drives, transformers, etc. The phase of this equipment shall be indicated on this label.
53. A ground conductor shall be installed with all underground, low, medium, and high voltage distribution circuits. All electrical distribution systems shall be 4-wire.
54. The Electrical Engineer of Record shall be present during the final inspection to validate that

all electrical installation meets the intent of the electrical construction documents he or she prepared. If the electrical installation fails, the Engineer-of-Record shall physically return for each subsequent inspection until the system passes. The Engineer of Record shall provide a letter on company letterhead indicating the system meets the intent of the design. During each inspection, all deficiencies shall be documented in writing and provided to the Government for review. The Engineer of Record shall include this cost as part of his fee proposal under indirect design costs. Note: This applies to design-build and design-bid-build projects and service contracts.

55. During the final inspection, the contractor shall have all electrical panelboards open, pad mounted transformer cabinets open, dry-type transformer covers removed, and manhole / handhole covers removed so the electrical connections and wiring can be inspected.
56. Updated electrical as-built drawings shall be submitted after the interior and exterior electrical distribution system installation portion of each building or each segment of electrical infrastructure of a project is completed and prior to a final inspection. The drawings shall be submitted in both electronic and “red-lined” paper formats. These updated drawings shall consist of two parts. The first part shall be an overall site plan with GPS coordinates and dimensions of all newly installed and/or expanded infrastructure (electrical distribution) hardware and equipment, i.e. riser poles, in-line poles, dead-end poles, manholes, handholes, generators, transformers, junction cabinets, sectionalizer cabinets, etc. The exterior electrical distribution plan shall be depicted as installed, showing street/road locations and names, and building “footprints” accurately oriented. Manholes/handholes, riser poles, in-line poles, dead-end poles, manholes, handholes, generators, transformers, junction cabinets, sectionalizer cabinets shall be depicted accurately oriented in relation to the buildings and roads. The construction and as-built drawings shall include a graphical scale.
57. The shop drawings shall be included in the as-built package. All information on the shop drawings shall be depicted on the final construction as-builts.
58. The following note shall be added verbatim on the drawings: Surge Protection Devices (SPDs) shall be listed in accordance with UL 1449-3rd Edition. SPDs shall provide protection L-N, L-G and N-G. SPD shall have a 200kAIC rating. SPDs shall have a surge current rating per mode of no less than 150kA and 300kA per phase and be modular in design. SPD shall have a 20kA “In” rating by UL and be rate as a Type 1 Device. Both the “Type” rating and the “In” rating must be listed as part of the UL label on the product. The SPD must qualify for UL 96A Lightning Protection System (LPS) Master Labeling. SPD shall have a ten (10) year warranty. SPD shall be equipped with an integral disconnecting means for application where no breaker is available such as in a retrofit application. SPD shall have dry contact for remote monitoring, an audible alarm redundant indication per phase and per mode and a transient event counter. SPD shall have a maximum VPR rating by UL of 1200V, L-N and L-G on a 277/480V system and 800V, L-N and L-G on a 120/208V system. SPD enclosure shall have a NEMA 4 rating for indoor and outdoor use.
59. The attached General Notes shall be included on all drawings.
60. The attached “General Notes” in Section “D” shall be added to all electrical drawings. Modify the voltages configuration as required to comply with the application. Modify item #30 as required to comply with panelboard name terminology.
61. The attached “Typical Equipment Labeling Detail” in Section “E” shall be on all construction drawings. Modify voltage configurations to comply with the application.

62. Any design, design-build, or design-bid-build project shall comply with specification section 16015B.
63. The Contractor or Engineer of Record shall provide the 2014 Understanding the National Electric Code Volumes 1 and by Mike Holt 1-888-632-2633.
64. In addition to normal design review conferences, coordination conferences may be held from time to time as required either by the Contractor, Engineer of Record (EOR) or the Air Force. The EOR may request such conferences when it is deemed necessary by both parties to clarify the work or expedite the preparation of plans and specifications. The EOR shall be responsible for making memoranda for record of any conversations and minutes of any meetings with Government personnel concerning the project. The EOR shall forward one copy of these memoranda/minutes to each party concerned and one copy to the Contracting Officer. Each copy shall be numbered consecutively and chronologically.
65. Regarding outdoor compressor/condenser units: Conduit and wiring leaving the load side of the non-fused-disconnect shall be routed down the wall and underground (36" below finished grade) and then routed up 12" above finished grade adjacent to the compressor/condenser unit as required. Connect to compressor/condenser unit using liquid tight flexible metallic conduit (36" maximum length) and wiring.
66. Heat strips shall be installed as an integral part of the air handling unit (AHU), and power connection shall be a single point, hence there should be only one circuit run to the AHU. The only exception to this paragraph is if a variable frequency drive is specified to serve the AHU. The attached "Typical AHU Wiring Diagram" and notes 33 through 35 shall be provided on the drawings.
67. Indicate the following on the electrical drawings: Bare copper lightning protection materials shall not be installed on aluminum roof or siding or other aluminum surfaces and vice-versa, aluminum lightning protection materials shall not be installed on copper roofing, copper siding, or other copper surfaces.
68. All lightning protection systems shall have a counterpoise extending around the facility or structure. There shall be $\frac{3}{4}$ "x20' ground rods at each corner of the facility or structure in fiberglass test wells.
69. Show all building elevations (north, south, west, and east) showing the 150' or 100' arc identifying the area of coverage.
70. All Air Terminals 24" or greater shall be tripod type.
71. Indicate the size (cross-sectional area) of the main lightning protection system copper conductors on the drawings.
72. Indicate the size (cross-sectional area) of the secondary lightning protection system copper conductors on the drawings.
73. The lightning protection system shall be certified by an Underwriters Laboratory (UL) inspector and a letter of certification shall be provided to the Contracting Officer (CO).
74. The following verbiage shall be provided on the drawings if a generator is being installed:

“Prior to generator installation, (set in place) the contractor shall notify the “Air Quality Manager.” The contractor is responsible for providing the information on the Internal Combustion Documentation Form. This form can be obtained from the 96 CEG Environmental Management, Air Quality Program Manager.

This form shall be completed in its entirety and submitted within 10 days of generator being set in place.

75. All transformers shall be sized to match or exceed the panel board ampacity it is serving. For example: If the maximum panelboard ampacity is 4000 Amps, then the transformer serving this equipment needs to have a secondary output rated at a minimum 4000 Amps.
76. All transformers shall be the delta-to-wye type that is delta primary and wye secondary, unless it is a 25KV system (use wye primary and wye secondary). Delta-to-zig-zag transformers are not allowed. Meaning do not specify a transformer with a zig-zag secondary.
77. Pad mounted transformers on 24,940V systems and above shall be the wye-to-wye type.
78. All pad mounted transformers shall be the dead front type.
79. All pad mounted transformers shall be the loop feed type.
80. The design Engineer of Record shall never indicate to install pole mounted transformers unless directed in writing by Eglin AFB Maintenance staff or Electrical Engineering staff. If directed by one of these entities to install a pole mounted transformer, then the primary shall be connected wye. All new transformers shall be pad mounted. This applies to all facilities permanent, temporary, etc.
81. Ground rods shall be 3/4”x20’ in each of the four corners of the pad mounted transformer.
82. All transformers, pad mounted and dry type, etc. shall be sized at minimum 125% of the connected load.
83. Do not connect new services or loads to existing overhead transformers, for new services and loads, provide new concrete pole and pad mounted transformer.
84. If a pad mounted transformer is being used for a 12,470V system, the transformer primary shall be designed to accommodate a 25KV class elbow without an adapter. A 15KV elbow cannot be hypoted at the required voltage level required by DoD specifications.
85. The Engineer of Record shall provide, in addition to the Government Estimate, supporting documentation from manufacturers or equipment distributors, the actual costs or equipment and hardware. The name and phone number of individual shall be provided and a description of the equipment hardware.
86. Where T-Bar ceilings are specified in spaces such as offices, conference rooms, and hallways, specify salient or equal characteristics as the Arcalux smart-fixture that has a 10-year warranty.
87. The Engineer of Record (EOR) shall design around a Lutron type lighting control system. The lighting control equipment and hardware shall have the same or equal salient characteristics as Lutron hardware and equipment.

88. If Engineer of Record chooses to use a wireless type lighting control system, then specify a lighting control system (to include lighting panel) that operate at 434 MHz.
89. Projects shall contain occupancy sensors or daylight sensors in restrooms, private and open offices, hallways, and other areas as directed by the Air Force. These sensors shall operate on a system that operates at 434 MHz.
90. All interior and exterior electrical equipment and hardware shall be indicated in the contract documents to be new. Never reuse existing equipment or hardware unless directed to do so in writing by one of the Eglin AFB, Chiefs of the Interior or Exterior Electrical Shop.
91. If a lighting control panel/system is installed, the system shall comply with the following instructions below: The instruction below shall be written into the contract documents verbatim.
 - a. Instructions shall be provided as required for operating the system. Hands-on demonstrations of the operation of all system components and the entire system, including program changes and functions, shall be included.
 - b. The Contractor and/or systems manufacturer's representatives shall provide a typewritten "Sequence of Operation".
 - c. Provide the manufacturer's recommended/required level of training on all installed equipment and software in regards to installation, operation, maintenance, testing, future expansion, and programming of the lighting control system for two (2) personnel. Testing and maintenance personnel, as well as, the manufacturer's required level of training, shall guarantee the unconditional operation and future purchase of additional and/or replacement equipment. The training shall take place at one of the locations normally used by the manufacturer and/or distributor to conduct factory training for their in-house employees. The government employees shall be trained alongside technicians employed by the installed equipment manufacturer and/or distributor. Upon successful completion of all curriculum requirements, the government personnel shall be awarded a certification and provided full access to all available technical support resources, to include but not be limited to, on-line and telephone support provided to manufacture and distributor personnel.
92. Show wire count in conduit for all power and lighting circuits. The lighting and power plans shall show the quantity of conductors in each conduit.
93. All Air-field taxiway, runway, and edge way lighting fixtures shall be the quartz type.
94. Wireless devices will not be incorporated into the design of Industrial Control Systems. If wireless devices are incorporated, authority to operate will be lost.
95. Strobe lights will be tested to ensure compliance with NFPA 72 18.5.5.5.2.
96. All panelboards, backboards, terminal cabinets, disconnects, service/convenience wall outlets, switches etc shall have custom engraved nameplates mechanically affixed identifying the system. Provide arc flash labeling for all panelboards identifying the system.
97. Fixed temperature heat detectors shall be used. Rate-of-rise detectors shall NOT be used

unless exclusively required by the design parameters to meet code.

98. The lettering for exit signs shall be red.
99. Battery capacity for all Fire Alarm Control Panels (FACP) shall be 48 hours. All other FACP code/spec requirements shall remain unchanged.
100. At all electronically operated vehicle gates, install a box and a siren feature for emergency access.
101. All facility fire alarm systems shall be zoned by device, floor, and area.
102. Field Fabricated Nameplates. Provide field fabricated nameplates in accordance with the following:
 - a. ASTM D709
 - b. Provide laminated plastic nameplates for each equipment enclosure, relay, switch, and device as specified or as indicated on the drawings
 - c. Each nameplate inscription: identify the function and, when applicable, the position
 - d. Nameplates: melamine plastic, 0.125 inch thick, white with black center core
 - e. Surface: matte finish. Corners: square. Accurately align lettering and engrave into the core
 - f. Minimum size of nameplates: one by 2.5 inches
 - g. Lettering size and style: a minimum of 0.25-inch-high normal block style

A14.3 EMERGENCY AND STANDBY GENERATOR REQUIREMENTS

1. The design of emergency and standby generators shall be in accordance with ETL 13-4: Standby Generator Design, Maintenance, and Testing Criteria
2. New and replacement generators require Air Force Civil Engineering Center (AFCEC) authorization, classification, and design approval. Authorization and classification shall be obtained in advance of design during the project planning and programming stage. IAW AFCEC direction, the only approved types of generators to be installed on Eglin AFB are Cummins brand generators.
3. Real Property Installed Equipment (RPIE) generator designs. All RPIE generator designs must be approved in writing by AFCEC/CO or designee prior to finalizing project purchase and/or programming and/or design. The approval memo becomes a part of the generator permanent record. Submit the generator authorization request during project initiation (programming) and design approval request at the 65% design milestone. If electrical design changes are made after the 65% design submittal, another design approval request is required.
4. Generator sizing. Existing, new, or replacement EAID or RPIE generator systems must be sized to achieve greater than 50% rated load and capable of supporting measured or calculated diversified, starting, and step load as defined by a qualified electrical design engineer.

5. Load Banks. For generator installations sized 250 kW and higher, the design must include provision for portable load bank/generator connection at the Automatic Transfer Switch (ATS) or distribution equipment (not at the generator). Size the connection at a minimum of the generator kW rating. In addition, if the facility load cannot achieve 75% of the generator kW rating, and a load bank of greater than 100 kW is required, a load bank of sufficient size shall be provided to achieve the required load.
6. Mission Uninterruptible Power Supplies (UPS). Mission UPSs installed to provide power conditioning and transitional backup power until RPIE generators assume the load must be configured to minimize UPS battery charging during generator operation. Ideally, UPS battery charging must be disabled. The generator will be sized for actual UPS mission critical loads and not based on maximum UPS capacity.
7. Replace all solid neutral (3-phase, 3-pole) ATSS with switched neutral (3-phase, 4-pole) ATSS whenever the existing generator or ATSS is replaced.
8. Medical Facility Generators. Design of medical military facility generators systems must comply with UFC 4-510-01.
9. Standby Generators for Hangar Door Secondary Operation. This is not normally accepted and must be strongly justified when a secondary manual method cannot be installed. Existing and new backup generator installations for hangar door systems required AFCEC/CO approval, including instances where the generator is supplied as part of the hangar door installation. If approved, connections must be located within four (4) feet of the hangar floor below the hangar door motor.
10. Automatic Transfer Switches. Transfer switches must have internal or external bypass capability. External ATSS bypass is preferred using two appropriately rated double-throw switches (one ahead of ATSS normal input and one connected to ATSS output).
11. Diversified Load: "Diversity factor" is the sum of individual maximum demands divided by the maximum demand on the power station (installed load/running load), is usually more than 1, and is mostly used for distribution feeder size and transformer, as well as to determine the maximum peak load. "Demand factor" is the maximum demand of a system divided by the total connected load on the system and is always less than 1. The lower the demand factor, the less system capacity required to serve the connected load. Demand factors should be applied when sizing generators. Diversity factor is typically used for sizing services at the transformer, so if it is not applicable to the design, it should be stated.
12. Use of natural gas, liquid petroleum gas, or bio-diesel fuels is not permitted for mission-essential standby generation.
13. Ensure fuel storage tanks are marked according to fuel type and warning signs are appropriately located. If an external fuel tank is installed, post a one-line diagram of the fuel system indicating tank size and valve locations.
14. RPIE generators will have a minimum 24-hour local capacity based on the actual generator load fuel consumption rate of the engine.
15. Spill buckets should be installed and be accessible on all storage tanks. (Full listing of federal/state/local requirements can be obtained from 96th CEG Environmental Management

Branch).

16. All ATS panels installed at outside locations must be NEMA 3 rated (rain resistant/waterproof).
17. Generation systems installed near coastal waters should have aluminum and/or stainless steel weather housing to prevent excessive corrosion. (Particularly, anything installed on Santa Rosa Island).
18. Generators must be registered with 96th CEG Environmental Management, Air Quality Program, prior to installation.
19. All fuel storage tanks must have operational and accessible fuel level gages installed.
20. Fuel storage tanks must have spill prevention/detection capability (double-walled with method of inspecting interstitial space).
21. Contracted generator installations should include the following before final acceptance inspection by the government:
 - a. Minimum 2-hour facility load testing
 - b. Manufacture training provided to 796 CES/CEOFP personnel
 - c. Two (2) full sets of Operation & Maintenance manuals, including a parts manual.
 - d. One (1) complete set of spare filters (Oil, Fuel, Fuel/Water, & Air)
 - e. Enough low sulfur diesel fuel in the tank to complete load testing and training of personnel (full tank is preferred).
 - f. All warranty information.
 - g. Copy of Air Quality Inventory Registration Form.
 - h. Any manufacturer testing documentation.



**DEPARTMENT OF THE AIR FORCE
AIR FORCE CIVIL ENGINEER CENTER
TYNDALL AIR FORCE BASE FLORIDA**



1 Dec 22

MEMORANDUM FOR RECORD

FROM: AFCEC/CO
139 Barnes Drive, STE 1
Tyndall AFB, FL 32403-5319

SUBJECT: Generator Standardization, Single Manufacturer Selection

1. This memorandum serves as AFCEC/CO's official communication approving the selection of a single manufacturer for generators respective to the following installation:

Installation:	Unit:	Manufacturer:
Eglin AFB	796 CES	Cummins

2. The comprehensive inventory analysis is to be repeated after five years from the date of this memorandum. The purpose of this secondary analysis is to document the installation's progress in standardizing generators, consider any changes in the decision facts, and confirm no external factors exist that may drive a reconsideration of the approved single manufacturer. Should the BCE determine that a change in single manufacturer is required, a new Memorandum of Request (MOR) and analysis will be accomplished.

3. Please direct any questions and/or concerns regarding implementation of this guidance to my POC, Mr. Bryan Muller, DSN 523-6291, bryan.muller.1@us.af.mil or to the AFCEC Reachback Center at AFCEC.RBC@us.af.mil.

KLEIN.JEFFREY.ROBERT.1266032575
BERT.1266032575
JEFFREY R. KLEIN, Lt Col, USAF
Deputy Director, Operations Directorate

Digitally signed by
KLEIN.JEFFREY.ROBERT.1266032575
Date: 2022.12.01 10:26:26 -06'00'

A14.4 EXTERIOR LIGHTING DESIGN REQUIREMENTS

Shall be IAW UFC 30530-1 and the Eglin Air Force Base Energy Savings Performance Contract

A14.5 GROUNDING DESIGN REQUIREMENTS

A14.6 SECURITY ALARM DESIGN REQUIREMENTS

A14.7 FIRE ALARM DESIGN REQUIREMENTS

A14.7.1 Fire Transceivers

- (a) All Fire Alarm transceivers shall be standalone BT-XFs and completely compatible with the existing Monaco Enterprises Model D-21-M central station system.
- (b) Transceivers shall have the appropriate number of zones to interface with the Fire Alarm Control Panel and other required equipment. The authority having jurisdiction shall approve the fire alarm zones. Transceivers shall operate on a frequency of 141.3625 MHZ. Transceivers shall not be mounted higher than 55 inches from floor level. Transceivers shall not be expanded beyond 48 fire alarm zones. Where more than 48 fire alarm zones are necessary, a second transceiver may be installed.

Notes:

Monaco Audio Board and Relay Board (BT-XMs) are not required and shall not be installed.

External activation (WIDE AREA CONTROL) of in-building live voice MNS will be the function of Command Post/ATHOC. A connection point or D-mark location shall be installed for future live voice input.

- (c) Lightning arrestors shall be mounted IAW installation manuals from the manufacturer and in a location easily accessible for maintenance with reasonable effort and without removal of additional facility finishes (sheet rock, ceiling grid, etc.).
- (d) The installer is responsible to determine the proper location and type of antenna to be utilized. When it is determined that the use of a directional, "Yagi," antenna the following shall apply. "Yagi" antennae installed on buildings shall be mounted on 1-inch heavy wall galvanized rigid conduit, utilizing positive means to prevent the antennae from twisting by wind.
- (e) In cases where the installer determines that an "Omni" antenna will be sufficient, that antenna may be mounted on $\frac{3}{4}$ inch rigid electrical conduit or a mast of proved equal strength. Both antenna types require good line of sight clearance for proper transmission and the Omni's grounding plane requires 3 feet of clearance over roofs and other objects.
- (f) Coaxial cable shall be enclosed in metal conduit from the transceiver to the antenna. In cases where overhead outdoor routing is deemed necessary, the cable shall be installed in accordance with all codes and directives. Coaxial cables running

overhead shall be approved for the purpose and installed accordingly. Cable length will be used to determine if low loss coaxial cable is necessary. Follow manufacturer's recommendation on cable length and type. Measures shall be taken to avoid sharp bends or "kinking" of coaxial cables. When direct transmission of signals to the fire dispatch center cannot be achieved the transmission may be routed through a repeater only with the permission of the supervisor of the alarm maintenance function. The installer shall demonstrate the forward and the reflected power of installed antenna systems prior to acceptance in accordance with manufacturer's specifications.

- (g) AC power sources for the transceiver shall be protected by surge/lightning suppressors. Suppressors shall not be installed within the enclosure of the transceiver.

A14.7.2 Fire Alarm and Mass Notification Systems

- (a) Control panels (FACUs) must be in office/administrative space or other rooms with similar temperature/humidity controls — control panels shall not be in the aircraft servicing areas or mechanical/utility spaces without both temperature and humidity controls. Simple heating (i.e., for freeze protection) and/or ventilation is not sufficient for these electronic systems. FACUs shall be mounted IAW NFPA 72 and Eglin Specific Requirements. Manufacturers are referenced in paragraph 2.3.
- (b) The following is an excerpt from one manufacturer's literature for their most current control system and clearly demonstrates this sensitivity. While the literature indicates compliance with NFPA 72 requirements, it clearly recommends much narrower environmental limits for locating the control panel.

1. Temperature and Humidity Ranges

This system meets NFPA requirements for operation at 0-49°C/32– 120°F and at a relative humidity 93% ± 2% RH (non-condensing) at 32°C ± 2°C (90°F ± 3°F). However, the useful life of the system's standby batteries and the electronic components may be adversely affected by extreme temperature ranges and humidity. Therefore, it is recommended that this system and its peripherals be installed in an environment with a normal room temperature of 15-27°C/60–80°F.

- (c) The following technician interface tool (laptop) requirements shall apply for intelligent fire alarm systems:

One laptop shall be turned over to the Electronic/Alarm (E/A) section with the latest approved operating system required for the programming the fire alarm software, the latest manufacturer's software required to program the FACP, a disc drive (to conform to Air Force security), and any associated systems or devices, to include: Vesda smoke detection, electrical/electronic fire pump controllers, etc... It should also contain software associated with developing documents (i.e. Microsoft Excel and Microsoft Word to perform load calculations and to run reports) as required by the programming software. All original manufacturers' software for each interface tool when addressable fire alarm systems are installed shall be provided to the Eglin AFB's E/A section. The following requirements shall apply: all software, hardware, passwords, cables, adapters, security keys (hasps and dongles) etc required for the

maintenance, testing, and reprogramming of the fire alarm system, support systems, and devices shall be unconditionally turned over to the E/A section, and the above noted software, hardware, passwords, etc will become the unconditional property of the government. Software turned over to Gov't shall be the original manufacturer's licensed software on cd (or DVD) with jeweled case; copies of software shall not be acceptable. Software and cd, or DVD, shall be brand new and unused.

- (d) The contractor shall provide the manufacturer's recommended/required level of training on all the installed equipment and software, regarding installation, operation, maintenance, testing, future expansion, and programming of the fire alarm system for two (2) personnel. This training shall meet or exceed NFPA 72 National F/A and Signaling Code 10.4.2.2 for System Installers, 10.4.3.1 (1) for Inspection, Testing and Maintenance Personnel as well as the manufacturer's required level of training and shall guarantee the unconditional operation and future purchase of additional and/or replacement equipment. The training shall take place at one of the locations normally used by the manufacturer and/or distributor to conduct factory training for their in-house employees. The government employees shall be trained alongside technicians employed by the installed equipment manufacture and/or distributor. Upon successful completion of all curricula requirements the government personnel shall be awarded a certification, security keys, and provided full access to all available technical support resources, to include at a minimum, on-line and telephone support provided to manufacture and/or distributor personnel. The Electronic/Alarm section will also require 8 hours, minimum, of familiarization training at the facility on the new panel, all new equipment, and the software. If media is submitted, it shall be filmed in 1080p or greater quality format from a tripod or gimbal.
- (e) Provide as-built drawings and a final testing points list of the fire alarm system, as follows: floor plans shall show all fire alarm system components and their addresses. Fire alarm riser diagram shall show all fire alarm components. Two copies of the programming and of any drawings will be provided to the Eglin Electronic/Alarm Maintenance section on CD, DVD, or thumb drive. Drawings need to be accessible and viewable with the laptop. Points list can be a paper or electronic list showing all points (description and address) to be tested for final acceptance. All requirements shall be accomplished prior to final acceptance.

Provide As-Built Drawings of Fire Alarm System as follows:

1. Floor Plan(s) showing all fire alarm system components and their addresses.
2. Fire alarm riser diagram showing all fire alarm components.
3. Fire alarm legend.
4. Fire alarm notes.
5. Above items 1 through 4 shall be provided electronically in .pdf format on CD with jewel case. Also, provide half-size (11x17) hardcopy.

A14.7.3 Fire Alarm Equipment

A14.7.3.1 This section of the specification includes the furnishing, installation, connection and testing of the microprocessor controlled, intelligent reporting fire alarm equipment required to form a

complete, operative, coordinated system. It shall include, but not be limited to, alarm initiating devices, alarm notification appliances, Fire Alarm Control Panel (FACP), auxiliary control devices, annunciators, and wiring as shown on the drawings and specified herein.

- (a) The fire alarm system shall comply with requirements of NFPA Standard No. 72 for Auxiliary Protected Premises Signaling Systems except as modified and supplemented by this specification. The system field wiring shall be supervised either electrically or by software-directed polling of field devices.
- (b) The fire alarm system shall comply with requirements of NFPA Standard No. 72 for Remote Station Protected Premises Signaling Systems except as modified and supplemented by this specification. The system field wiring shall be supervised either electrically or by software-directed polling of field devices.
- (c) The fire alarm system shall be manufactured by an ISO 9001 certified company and meet the requirements of BS EN9001: ANSI/ASQC Q9001-1994.
- (d) The installing company shall employ NICET (minimum Level III Fire Alarm Technology) technicians on site to guide the final check-out and to ensure the systems integrity.

A14.7.3.2 Scope:

An intelligent, microprocessor-controlled, fire alarm detection system shall be installed in accordance with the project specifications and drawings.

A14.7.3.2.1 Basic Performance for Intelligent Systems:

- (a) Alarm, trouble and supervisory signals from all intelligent reporting devices shall be encoded on NFPA Class B, A, or X only on the Signaling Line Circuits (SLC). Class B circuitry must be installed in series and T-taps will be allowed but must be kept to a minimum so that the resistance level is 10% below the manufacturer's maximum recommended resistance level. All T-taps shall be notated accordingly on as built drawings.
- (b) Notification Appliance Circuits (NAC) shall be wired Class A circuit, to ensure the circuit will operate as designed with only one fault.
- (c) All circuits shall be power-limited, UL864 9th edition requirements.
- (d) A single ground fault on the system Signaling Line Circuit shall not cause system malfunction, loss of operating power or the ability to report an alarm.
- (e) All AC power to the fire systems shall be protected by using surge/lightning protectors. All circuits of the fire systems that enter or exit the protected facility shall have surge/lightning protectors installed. NOTE: **DO NOT** install AC power surge suppressors inside the FACP cabinet.
- (f) Provide a lock-on breaker in the branch panelboard that serves as the primary power supply for the fire protection system. If more than one fire protection circuit is required, provide a panelboard (sized for a minimum of six circuits) dedicated to fire protection and life safety systems powered from a lock-on breaker in the upstream

distribution equipment.

- (g) For facilities that are provided with backup power supplies (i.e. engine driven generator, energy storage system, etc.), fire protection systems must be powered by the backup power supply system. Note: Preferably if there is a generator and a Facility UPS system, connect the Fire & Life safety systems to the UPS system.

A14.7.3.3 Submittals:

A14.7.3.3.1 General:

- (a) Two copies of all submittals shall be submitted to the CE SABER PM/CE Engineer for review.
- (b) All references to manufacturer's model numbers and other pertinent information herein are intended to establish minimum standards of performance, function, and quality. Equivalent compatible UL-listed equipment from other manufacturers may be substituted for the specified equipment if the minimum standards are met.
- (c) For equipment other than that specified, the contractor shall supply proof that such substitute equipment equals or exceeds the features, functions, performance, and quality of the specified equipment.

A14.7.3.3.2 Shop Drawings:

- (a) Sufficient information, clearly presented, shall be included to determine compliance with drawings and specifications.
- (b) Include manufacturer's name(s), model numbers, ratings, power requirements, equipment layout, device arrangement, complete wiring point-to-point diagrams, and conduit layouts.
- (c) Show annunciator layout, configurations, and terminations.
- (d) Wiring diagrams shall indicate internal wiring for each device and the interconnections between the items of equipment.

A14.7.3.3.3 Manuals:

- (a) Submit simultaneously with the shop drawings, installation, programming, operating, and maintenance manuals listed for the manufacturer's panel and product(s), including technical data sheets. This applies to panels installed; main, sub, releasing, etc.
- (b) Provide a clear and concise description of operation that gives, in detail, the information required to properly operate the equipment and system.
- (c) Provide one complete sets of manuals to Civil Engineering Electronic/Alarm maintenance section at acceptance (can be on a compact disc or thumb drive).

A14.7.3.3.4 Software Modifications:

- (a) Provide all hardware, software, programming tools and documentation necessary to modify the fire alarm system on site. Modification includes addition and deletion of devices, circuits, zones and changes to system operation and custom label changes for devices or zones. The system structure and software shall place no limit on the type or extent of software modifications on-site. Modification of software shall not require power-down of the system or loss of system fire protection while modifications are being made.

A14.7.3.4 Guaranty

All work performed and all material and equipment furnished under this contract shall be free from defects and shall remain so for a period of at least one (1) year from the date of acceptance. The full cost of maintenance, labor, and materials required to correct any defect during this one-year period shall be included in the submittal bid.

A14.7.3.5 Applicable Standards and Specifications:

The specifications and standards listed below form a part of this specification. The system shall fully comply with the latest issue of these standards, if applicable.

- (a) National Fire Protection Association (NFPA) - USA:
 - No. 13 Sprinkler Systems
 - No. 70 National Electric Code (NEC)
 - No. 72 National Fire Alarm Code
 - No. 101 Life Safety Code
- (b) All Unified Facilities Criteria (UFC)
- (c) The system and its components shall be Underwriters Laboratories, Inc. listed under the appropriate UL testing standard as listed herein for fire alarm applications and the installation shall comply with the UL listing.
- (d) Local and State Building Codes.
- (e) All requirements of the Authority Having Jurisdiction (AHJ).

A14.7.3.6 Approvals

- (a) The system shall have proper listing and/or approval from the following nationally recognized agencies:
 - UL Underwriters Laboratories Inc.
 - ULC Underwriters Laboratories Canada
 - FM Factory Mutual
 - MEA Material Equipment Acceptance (NYC)
 - CSFM California State Fire Marshal

A14.7.4 Products

A14.7.4.1 Equipment and Material, General:

- (a) All equipment and components shall be new, and the manufacturer's current model. The materials, appliances, equipment, and devices shall be tested and listed by a nationally recognized approvals agency for use as part of a fire protective signaling system, meeting the National Fire Alarm Code.
- (b) All equipment and components shall be installed in strict compliance with manufacturers' recommendations. Consult the manufacturer's installation manuals for all wiring diagrams, schematics, physical equipment sizes, etc., before beginning system installation.
- (c) All equipment shall be attached to walls and ceiling/floor assemblies and shall be held firmly in place (e.g., detectors shall not be supported solely by suspended ceilings). Fasteners and supports shall be adequate to support the required load.

A14.7.4.2 Conduit and Wire

A14.7.4.2.1 Conduit

- (a) Conduit shall be in accordance with The National Electrical Code (NEC), local, and state requirements.
- (b) All wiring shall be installed in conduit or raceway. Conduit fill shall not exceed 40 percent of interior cross-sectional area where three or more cables are contained within a single conduit.
- (c) Conduit shall not enter the fire alarm control panel or any other remotely mounted control panel equipment or back boxes, except where conduit entry is specified by the FACP manufacturer.
- (d) Conduit shall be 3/4-inch (19.1 mm) minimum, red in color.

A14.7.4.2.2 Wire

- (a) All fire alarm system wiring shall be new.
- (b) Wiring shall be in accordance with local, state, and national codes (e.g., NEC Article 760) and as recommended by the manufacturer of the fire alarm system. Number and size of conductors shall be as recommended by the fire alarm system manufacturer, but not less than 18 AWG (1.02 mm) for Initiating Device Circuits and Signaling Line Circuits, and 14 AWG (1.63 mm) for Notification Appliance Circuits.
- (c) Wiring for 24-volt DC control, alarm notification, emergency communication and similar power-limited auxiliary functions may be run in the same conduit as initiating and signaling line circuits. All circuits shall be provided with transient suppression devices and the system shall be designed to permit simultaneous operation of all circuits without interference or loss of signals.
- (d) Wiring installation — practices in ANSI/NECA 305-2001 shall be followed. Cable

must be separated from any open conductors of power, or Class 1 circuits, and shall not be placed in any conduit, junction box or raceway containing these conductors, per NFPA 70 Article 760-136. Power wiring and limited power wiring shall not be co-located in the same conduit, raceway, or enclosure. Such wiring may only be located together within the listed control panel and shall be installed in accordance with the manufacturer's guidance. There should be no stray detectable voltages, no ground faults, open circuits, or short circuits when tested IAW NEC 305.

- (e) All wire and cable shall be listed and/or approved by a recognized testing agency for use with a protective signaling system.
- (f) Wire and cable not installed in conduit shall have a fire resistance rating suitable for the installation as indicated in NEC 760 (e.g., FPLR).
- (g) All field wiring shall be electrically supervised for open circuits and ground faults. UFC 3-600-01 states that wiring between devices shall be splice free.

A14.7.4.2.3 Terminal Boxes, Junction Boxes and Cabinets

All boxes and cabinets shall be UL listed for their use and purpose. They shall be installed to have a working clearance that is unobstructed and be readily accessible.

A14.7.4.2.4 Main Fire Alarm Control Panel

The fire alarm control panel (FACP) shall be one of two manufacturers: Notifier Onyx or Fire-Lite. A third manufacturer, Detronic panels, is currently the only AFCEC approved releasing type panel for use in Air Force hangars. This falls under AFCEC's category of "Management Initiative" to reduce excessive maintenance, training, and support costs. It shall be intelligent and contain a microprocessor-based Central Processing Unit (CPU). The CPU shall communicate with and control the following types of equipment used to make up the system: intelligent initiating devices, addressable modules, printer, annunciators, and other system-controlled devices.

- (a) It should contain all correct modules and printed circuit boards required for the designed system.
- (b) The fire alarm control panel shall be connected to a separate dedicated 120-VAC branch circuit, maximum 20 amperes. This circuit shall be labeled at the main power distribution panel as FIRE ALARM. Fire alarm control panel primary power wiring shall be 12 AWG. The control panel cabinet shall be grounded securely to facility ground. The control panel enclosure shall feature a quick removal chassis to facilitate rapid replacement of the FACP electronics.
- (c) The FACP shall be capable of coding Notification Appliance Circuits in March Time Code (120 PPM), Temporal (NFPA 72 A-2-2.2.2), and California Code. Main panel notification circuits (NACs 1 & 2) shall also automatically synchronize any of the following manufacturer's notification appliances connected to them: System Sensor, Wheelock, or Gentex with no need for additional synchronization modules.
- (d) No more than one Main FACU shall reside in a facility. Nodes are acceptable for addressable systems of the same manufacturer. If an older conventional system is in the same facility, it shall either be totally removed and upgraded with the rest of the system or incorporated into the addressable system by removing the FACU, using conventional zone cards and either integrating the NAC circuits to the main FACU or adding a NAC expander.



DEPARTMENT OF THE AIR FORCE
AIR FORCE CIVIL ENGINEER CENTER
TYNDALL AIR FORCE BASE FLORIDA

5 Jan 2023

MEMORANDUM FOR RECORD

FROM: AFCEC/CO
139 Barnes Drive, STE 1
Tyndall AFB, FL 32403-5319

SUBJECT: Fire Alarm Panel Standardization, Up to 3 Manufacturer Brands can be selected

1. This memorandum serves as AFCEC/CO's official communication approving the selection of 2 manufacturers for Fire Alarm Panels respective to the following installation:

Installation:	Unit:	Manufacturers:
Eglin AFB	796 CES	Notifier Onyx, Firelite

2. The comprehensive inventory analysis is to be repeated after five years from the date of this memorandum. The purpose of this secondary analysis is to document the installation's progress in standardizing fire alarm panels, consider any changes in the decision facts, and confirm no external factors exist that may drive a reconsideration of the approved single manufacturer. Should the BCE determine that a change in the approved manufacturers is required, a new Memorandum of Request (MOR) and analysis will be accomplished.

3. Please direct any questions and/or concerns regarding implementation of this guidance to my POC, Mr. Efreem Rivers, DSN 523-6764, efrem.rivers.1@us.af.mil or to the AFCEC Reachback Center at AFCEC.RBC@us.af.mil.

KLEIN.JEFFREY.ROBERT.1266032575
Digitally signed by
KLEIN.JEFFREY.ROBERT.1266032575
75
Date: 2023.01.06 08:34:00 -06'00'
JEFFREY R. KLEIN, Lt Col, USAF
Deputy Director, Operations Directorate

A14.7.5 System Components

All interfaces and associated equipment are to be protected so that they will not be affected by voltage surges or line transients consistent with UL standard 864.

(a) Fire Alarm Initiating Devices:

1. Shall be compatible with the installed FACP
2. Shall be addressable, UL listed, and of a new condition. All initiating devices shall have a label identifying the node, loop, & address. ex: N1L1D001
 - (i) Manual stations shall be non-glass break, shall have a visual indication that it has been set off, have a key lock for reset and testing, the word "FIRE" shall be on it, (Manual discharge or agent release stations shall not be located within 5 feet of a manual fire alarm pull station. When a manual foam discharge station and a manual fire alarm station are both located at a doorway the stations shall be located on opposite sides of the doorway. Manual discharge or agent release stations shall be housed under a clear plastic tamper proof cover. They shall comply with the signage and color coding in ETL 02-15 UFC 4-211-01).
 - (ii) Heat Detectors shall have a fixed temperature rating for the area/s of installation (135 degrees Fahrenheit (57.2 Celsius) for areas where ambient temperatures do not exceed 100 degrees (37.7 Celsius), and 200 degrees (93.33 Celsius) for areas where the temperature does not exceed 150 degrees (65.5 Celsius), shall be of low profile, shall fit the environment (paint booth, fuel vapors, etc.).
 - (iii) Smoke Detectors shall use the photoelectric (light-scattering) principal to measure smoke density and on command from the control panel, send data to the panel representing the analog level of smoke density.
 - (iv) Laser Smoke Detectors shall have nine sensitivity levels and be sensitive to a minimum obscuration of 0.03 percent per foot; shall support standard, relay, isolator, and sounder detector bases; shall not require other cleaning requirements than those listed in NFPA 72; and shall include two bicolor LEDs that flash green in normal operation and turn on steady red in alarm.
 - (v) Duct Smoke Detectors shall be installed upon the composite supply/return air ducts, be installed with properly sized air sampling tubes that visually extend through the air duct, activation shall shut down units and close dampers, etc. as designed by the FPE, and shall be resettable at the FACP. They shall be reset using the FACP's reset switch and/or a key operated test/reset switch located near the detector. When any Duct Smoke detector is installed higher than 96 inches or not easily accessible from the ground, a remote test switch shall be installed.

- (vi) Multi-Criteria Detectors shall monitor a minimum of photoelectric and thermal technologies in a single sensing device, shall be able to adapt to its environment, and shall allow a wide sensitivity window with no less than 1 to 4% per foot obscuration. The design shall be capable of selecting the appropriate sensitivity levels based on the environment type it is in (office, manufacturing, kitchen etc.) and shall also include the inherent ability to distinguish between a fire condition and a false alarm condition by examining the characteristics of the thermal and smoke sensing chambers and comparing them to a database of actual fire and deceptive phenomena.
- (vii) Flow, Pressure, and Tamper Switches (mechanical switching devices); shall be installed on suppression systems and monitored by the appropriate electronic modules connected to the FACP.
- (viii) Very Early Warning Fire Detection (VEWFD) shall only be installed per UFC 3-600-01 and NFPA 76 or where RF (radio frequency) signals might interfere with equipment and generate false alarms.

(b) Notification Appliances:

1. Shall be compatible with the installed FACP.
2. Shall be UL listed and of a new condition.
3. Shall have an audible sound level of 84-90 dB measured at 10 feet from the device.
 - (i) Horn/Strobes and Sounder Bases shall operate on 24 VDC nominal, shall be field programmable without the use of special tools, and shall be flush or surface mounted as shown on plans.
 - (ii) Speakers shall operate on 25 or 70 VRMS or with field selectable output taps from 0.5 to 2.0 Watts, shall produce a nominal sound output of 84 dB at 10 feet (3m), and shall have a frequency response at a minimum of 400 HZ to 4000HZ. The back of each speaker shall be sealed to protect the speaker cone from damage and dust.
 - (iii) Strobe Lights shall meet the requirements of the ADA, UL Standard 1971, be fully synchronized, shall have a maximum pulse duration of 2/10 of one second. Intensity and flash rate shall meet the requirements of UL 1971. Globes shall have clear lenses and shall be marked "ALERT". Strobes should remain active after system is silenced and ONLY reset once the system has returned to a non-alarm state.
 - (iv) Textual Signs: shall be at points of egress for the hearing impaired and shall have no display text when idle.
 - (v) All NAC devices shall have a label/nameplate identifying what NAC

circuit it is on node/nac circuit. i.e N1NAC1 or if on an extender, i.e N1Ext1NAC1

- (vi) All end of line (EOL) devices shall have a label/nameplate identifying that device as an EOL device and shall be identified on the As-built drawings
- (b) Monitor/Control/Isolation Modules:
- 1. Shall be compatible with the installed FACP.
 - 2. Shall be UL listed, and of a new condition.
 - (i) Zone/Monitor Modules: shall be provided to connect one supervised IDC zone of conventional alarm initiating devices (any N.O. dry contact device) to one of the fire alarm control panel SLCs and shall have a LED flash under normal conditions and a distinctive indication for an alarm condition. For difficult to reach areas, the monitor module shall be available in a miniature package and shall be no larger than 2-3/4 inch (70 mm) x 1-1/4 inch (31.7 mm) x 1/2 inch (12.7 mm). It shall also be capable of addresses 1 thru 159, IDC zone modules shall be wired for Class A operation.
 - (ii) Control/Relay Modules: shall be provided to supervise and control the operation of one conventional NACs of compatible, 24 VDC powered polarized audio/visual notification appliances. NAC audio/visual power shall be provided by a separate supervised power circuit from the main fire alarm control panel or from a supervised UL listed remote power supply. Control modules shall be suitable for pilot duty applications and rated for a minimum of 0.6 amps at 30 VDC and shall be capable of addresses 1 thru 159. Relay modules shall be available for HVAC control and other building functions, and relay module contacts shall be form C and rated for a minimum of 2.0 Amps resistive or 1.0 Amps inductive.
 - (iii) Isolator Modules: shall be provided to automatically isolate wire-to-wire short circuits on an SLC Class A or Class B branch, shall automatically open-circuit (disconnect) the SLC during a short condition and shall automatically reconnect the isolated section, shall provide a single LED that shall flash to indicate that the isolator is operational and shall illuminate steadily to indicate that a short circuit condition has been detected and isolated, shall not be necessary to replace or reset an isolator module to its normal operation, at least one isolator module shall be provided for each floor or protected zone of the building.
 - (iv) Alphanumeric LCD Type Annunciator: shall be a supervised, remotely located back-lit LCD display containing a minimum of eighty (80) characters for alarm annunciation in clear English text, shall display all alarm and trouble conditions in the system, shall be possible to connect up to 32 LCD displays and be capable of wiring distances up to 6,000 feet, shall connect to a separate dedicated

"terminal mode" EIA-485 interface, shall be capable of the following system functions: Acknowledge, Signal Silence and Reset and will be protected from unauthorized use by a key switch or password, shall be UL listed.

A14.7.6 Batteries

Batteries are to be completely maintenance free and none of them no larger than 55 amp-hour. If a larger capacity is figured, parallel sets of batteries, 55 A/H and smaller together. The handling of larger batteries has produced an inherent safety hazard. Fluid level checks for refilling, spills, and leakage shall not be required. Batteries shall have sufficient capacity to power the fire alarm system for not less than 48 hours of supervision, plus 15 minutes of alarm notification upon a normal AC power failure, and batteries shall be labeled with the date of installation. If necessary to meet standby requirements, external battery and charger systems may be used.

A14.7.7 Execution

The Electronic/Alarm and Fire Suppression Section of 96 CEG are technical support to the Authority Having Jurisdiction (AHJ) only. Their responsibility is to review, inspect, and observe tests. They shall not participate in the execution of any portion of an awarded project. Examples of what they will NOT do are; disable, safe, or shut down a complete or partial system, bring systems back on-line, etc. during project execution.

Before any Technician will program the fire alarm transceiver for any project, the Electronic/Alarm Section require the following items to be in their possession; NFPA 72 Record of Completion, a test plan, a copy of all test results (meggar, smoke sensitivity, resistance, intelligibility, and any device and panel), a set of working drawings, sized 12 X 18, the box of spare parts, the technician interface tool (laptop, if required) plus any special connecting cables or devices to interface with all systems to include VESDA, fire pump controllers, and flame detectors, a copy of all data bases on a thumb drive, and (1) copy of all manuals (installation, programming, & operation), which now can be electronic.

A14.7.7.1 Installation

- (a) Installation shall be in accordance with the NEC, NFPA 72, local and state codes, as shown on the drawings, and as recommended by the major equipment manufacturer.
- (b) All Fire Alarm Control Panels and BT-XF transceivers shall be mounted in conditioned air space and no higher than 55 inches from the finished floor to top of the enclosure. A 120v receptacle shall be within 6 feet of the FACU BT-X or any node.
- (c) All fire detection and alarm system devices, control panels and remote annunciators shall be flush mounted when located in finished areas and may be surface mounted when located in unfinished areas.
- (d) Manual fire alarm boxes shall be suitable for surface mounting or semi-flush mounting as shown on the plans and shall be installed not less than 42 inches (1067 mm), nor more than 48 inches (122 mm) above the finished floor.

A14.7.7.2 Testing

The service of a competent, factory-trained engineer or technician authorized by the manufacturer of the fire

alarm equipment shall be provided to technically supervise and participate during all the adjustments and tests for the system. All testing shall be in accordance with NFPA 72.

- (a) Each of the alarm conditions that the system is required to detect should be introduced on the system. Verify the proper receipt and the proper processing of the signal at the FACP and the correct activation of the control points.
- (b) When the system is equipped with optional features, the manufacturer's manual shall be consulted to determine the proper testing procedures. This is intended to address such items as verifying controls performed by individually addressed or grouped devices, sensitivity monitoring, verification functionality and similar.

A14.7.7.3 Final Inspection

At the final inspection, a factory-trained representative of the manufacturer of the major equipment shall demonstrate that the system functions properly in every respect, including connection to with the “Technician Interface Tool” (laptop). Also, provide a box of spare components (smoke detectors, pull stations, etc...), at least two of each device installed on the system. This does not include spare panels, NAC power supplies, or transceivers. At least (2) representatives shall be on site for the final inspection.

A14.7.7.4 Instruction

The contractor and/or the systems manufacturer's representatives shall provide a typewritten documents, to include; NFPA 72 report (listing all devices installed), a system narrative/description (a sequence of operation), a set of working drawings to include a riser diagram, equipment technical data sheets, battery and voltage drop calculations, a written record of completion, a service directory; to include a list of names who’s providing service during the warrantee period, and As- built drawings in a true half size (11 X 17).

A14.8 EGLIN FIRE ALARM & MNS TESTING PROCEDURES

Eglin Fire Alarm and MNS Testing procedures are as detailed below.

1. Contractor submits the FACP and building transceiver (BT) zone designations to USACE or USAF equivalent as soon as they are finalized. These should match the approved shop drawings. Without these, the BT and FD Central Station Equipment cannot be programmed.
2. USACE or USAF equivalent will pass these zone designators to the Eglin MILCON project liaison. The liaison will coordinate these through the Fire Department and Fire Alarm (F/A) Shop.
3. Once the zone designators are concurred with, the F/A Shop will program the Central Station.
4. The MILCON liaison will schedule a time with the Contractor and F/A Shop so the F/A Shop can energize the transceiver and prepare it for download. At that time, the F/A Shop will download the program and perform an initial verification of the program with the electrical sub present. NOTE: The Contractor shall coordinate with dispatch (882-5856) prior to, and at the conclusion of, all testing. Contractor shall turn the transceiver OFF so no false alarms can be sent after each test until acceptance testing is successfully completed.
5. Contractor performs their preliminary testing of the F/A-MNS systems.
6. Contractor contacts USACE to witness a complete testing of the system. This also includes

verifying that fire dispatch receives all FACP zones as approved, all the MNS messages, the batteries pass the specified required test, and the initial wattage output test of the transceiver (part of the manufacturer's testing requirements) meets manufacturer's requirements.

7. Once USACE or USAF equivalent concurs that the system is ready for acceptance testing, USACE or USAF equivalent shall turn over the O&M manuals, a completed Fire Alarm Emergency Communication System Inspection and Testing Form, as called out in NFPA 72, all voice intelligibility readings, and the requested test date/time. USACE will also ensure that the preliminary (red-lined is acceptable) F/A as-built are available at acceptance testing.
8. The MILCON liaison will coordinate this date/time with the F/A Shop and Base FD to turn over all items delivered in item #7 above.
9. The Contractor shall disconnect commercial power to the F/A-MNS systems for the duration called out in the project specifications so that this timeframe will coincide with the beginning of the acceptance test. This disconnection shall be properly labeled with lock out / tag out procedures.
10. On the agreed upon testing date/time, the contractor will first test the F/A-MNS systems on battery power as called out in the project specifications. F/A-MNS is 48 hours on back-up battery and then 15 minutes in alarm condition and the MNS has a separate secondary back-up power test, turn off power and turn on the entire system for 60 minutes.
11. Commercial power will then be restored, and the contractor will continue with the final acceptance testing. The contractor shall perform a wattage output test and complete the final acceptance testing (F/A Shop / Base FD will verify with the fire dispatch that the signals are being properly received at the dispatch computer and that they are being correctly identified on the FACP/BT). NOTE: If a laptop computer is required by contract, it shall be available at this test and will be used to verify that all required software is properly installed. This computer will also be used for all contract required training.

A14.9 EGLIN FIRE ALARM & MNS TRAINING PROCEDURES

1. Instruction shall be provided as required for operating the system. Hands-on demonstrations of the operation of all system components and the entire system including program changes and functions shall be provided.
2. The contractor and/or the systems manufacturer's representatives shall provide a typewritten documents, to include; NFPA 72 report (listing all devices installed), a system narrative/description (a sequence of operation), a set of working drawings to include a riser diagram, equipment technical data sheets, battery and voltage drop calculations, a written record of completion (NFPA 72), a service directory; to include a list of names who's providing service during the warrantee period, and As- built drawings in a true half size (12 X 18).
3. Provide the manufacturer's recommended/required level of factory training on all the installed equipment and software, regarding installation, operation, maintenance, testing, future expansion, and programming of the fire alarm system for two (2) personnel. This training shall meet or exceed NFPA 72 National F/A and Signaling Code 10.5.3 for System Installers, Inspection, Testing and Maintenance Personnel as well as the manufacturer's required level of training and shall guarantee the unconditional operation and future purchase of additional and/or replacement equipment. The training shall take place at one of the

locations normally used by the manufacturer and/or distributor to conduct factory training for their in-house employees. The government employees shall be trained alongside technicians employed by the installed equipment manufacture and/or distributor. This goes for all systems being installed, to include, but not limited to the main fire alarm system, subordinate releasing panels, VESDA systems, mass notification textual sign systems, electrical/electronic fire pump controller, and clean agent systems. Upon successful completion of all curriculum requirements, the government personnel shall be awarded full access to all available technical support resources, to include at a minimum, on-line and telephone support provided to manufacture and/or distributor personnel.

Appendix 15 – Eglin Specific Corrosion Control and Cathodic Protection Requirements

No specific requirements.

Appendix 16 – Eglin Specific Telecommunications Requirements

Refer to 96th Communications Squadron’s Cyber Infrastructure Standards and Installation Specifications.

A16.1 COMMUNICATIONS EQUIPMENT BACKER BOARDS

A16.1.1 Plywood backer boards shall be stamped as FIRE RESISTANT. Fire resistant paint is not acceptable. Manufacture’s stamp shall be visible.

A16.1.2 Telecommunications facilities, rooms and spaces shall use antistatic flooring with low propensity to static or electrostatic discharge.

Appendix 17 – Eglin Specific Cost Estimate Requirements

No specific requirements.

Appendix 18 – Eglin Specific Antiterrorism / Force Protection

A5.1. Bollards

The following shall be the Eglin Specifications for security bollards:

OPTIONS:

1. STANDARD STEEL HEAVY WEIGHT OVER 100LBS
2. MEDIUM STEEL WEIGHT FD APPROVED UNDER 50LBS
3. STAINLESS STEEL MEDIUM WEIGHT FD APPROVED UNDER 50LBS

REQUIREMENTS:

1. STEEL STANDARD BOLLARD

HEIGHT: 6 FEET
OUTSIDE CIRCUMFERENCE: 1 FOOT 6 INCHES
WALL THICKNESS: ¼ INCH (SCHEDULE 40)

TOP HANDLE: 1 INCH FROM TOP OF BOLLARD
 TOP HANDLE LENGTH: 8 INCHES
 MIDDLE HANDLE: 2 FEET 7 INCHES FROM TOP OF BOLLARD
 MIDDLE HANDLE LENGTH: 8 INCHES
 NUMBER OF HANDLES: 4 PER BOLLARD ON OPPOSITE SIDES
 3M REFLECTIVE TAPE: 3 INCHES WIDE
 1ST STRIPE: 4 INCHES FROM TOP OF BOLLARD
 2ND STRIPE: 11 1/2 INCHES FROM TOP OF BOLLARD
 3RD STRIPE: 18 INCHES FROM TOP OF BOLLARD
 NOTE: 3 STRIPES PER BOLLARD
 COLOR: 37769 from Federal Standard 595B color chart

2. *2010 ADDED: STEEL FIRE APPROVED MEDIUM WEIGHT BOLLARD

HEIGHT: 6 FEET
 OUTSIDE CIRCUMFERENCE: 1 FOOT 6 INCHES
 WALL THICKNESS: 1/8 INCH (SCHEDULE 10)
 TOP HANDLE: 1 INCH FROM TOP OF BOLLARD
 TOP HANDLE LENGTH: 8 INCHES
 MIDDLE HANDLE: 2 FEET 7 INCHES FROM TOP OF BOLLARD
 MIDDLE HANDLE LENGTH: 8 INCHES
 NUMBER OF HANDLES: 4 PER BOLLARD ON OPPOSITE SIDES
 3M REFLECTIVE TAPE: 3 INCHES WIDE
 1ST STRIPE: 4 INCHES FROM TOP OF BOLLARD
 2ND STRIPE: 9 INCHES FROM TOP OF BOLLARD
 3RD STRIPE: 14 INCHES FROM TOP OF BOLLARD
 4TH STRIPE: 19 INCHES FROM TOP OF BOLLARD
 NOTE: 4 STRIPES PER BOLLARD
 COLOR: 37769 from Federal Standard 595B color chart

3. (STAINLESS STEEL BOLLARD 2010 OPTION) FIRE APPROVED MEDIUM WEIGHT**

MATERIAL – STAINLESS STEEL – SCHEDULE 10 SIZE – 5 INCH DIAMETER

HEIGHT: 5 FEET - 48 INCHES ABOVE GROUND 12 INCHES IN
 GROUND SOCKET
 FINISH: STAINLESS STEEL – NO PAINT OR TAN COLOR
 REQUIRED

OUTSIDE CIRCUMFERENCE: 1 FOOT 6 INCHES
 WALL THICKNESS: 1/8 INCH (SCHEDULE 10)
 TOP HANDLE: 1 INCH FROM TOP OF BOLLARD
 TOP HANDLE LENGTH: 8 INCHES

MIDDLE HANDLE: 2 FEET 7 INCHES FROM TOP OF BOLLARD
 MIDDLE HANDLE LENGTH: 8 INCHES
 NUMBER OF HANDLES: 4 PER BOLLARD ON OPPOSITE SIDES
 3M REFLECTIVE TAPE: 3 INCHES WIDE
 1ST STRIPE: 4 INCHES FROM TOP OF BOLLARD
 2ND STRIPE: 9 INCHES FROM TOP OF BOLLARD
 3RD STRIPE: 14 INCHES FROM TOP OF BOLLARD
 4TH STRIPE: 19 INCHES FROM TOP OF BOLLARD
 NOTE: 4 STRIPES PER BOLLARD

BOLLARDS SHALL BE MANUAL LIFT AND NOT LOCKABLE TOP – FLAT OR DOME WELDED COVER

FIXED POST & BASE PLATE SECURITY BOLLARDS

Model IBF, SSF, & ABF

For most installations, fixed post security bollards provide solid, uncompromising protection against vehicle incursion. Embedded bollards with an engineered embedment offer the most dependable protection and come in Carbon Steel, Stainless Steel and Aluminum materials. For locations where surface penetration is impractical or impossible, plate-mounted bollards, in Carbon Steel or Stainless Steel keep property and pedestrians safe from most vehicle impacts.



Bollard, Embedded Security

Fixed embedded bollards are the most commonly used safety and security bollard. From protecting stationary objects such as an electrical junction box to providing a protective barrier for pedestrians on busy streets. Fixed bollards are simple to install and unlike concrete or other safety barriers, allow free pedestrian movement between the bollards.



Bollard, Base Plate Security

Fixed base plate bollards are used when the foundation slab available for mounting is too shallow for a deeper, more secure concrete footing. Base plate bollards are not designed for use in perimeter security application. Base plate bollards provide excellent protection in distribution centers and warehouses to protect loading dock doors, machinery inside the warehouse and other internal locations. Use in multi-level parking structures is another practical use for base plate bollards.

SLEEVES FOR SS BOLLARD STORAGE CAN BE PURCHASED AS ACCESSORIES SEE PHOTO BELOW

NOTE SS BOLLARDS REQUIRE ONLY A 12" IN GROUND SLEEVE AND ARE ONLY 5FT NOT 6FT LIKE STEEL BOLLARDS.

Bollard Storage Sleeves



Storage sleeves for 1 to 6 Retractable Bollards

STEEL BOLLARD SLEEVE

TOTAL LENGTH WITHOUT BOTTOM STEM:	2 FEET 6 INCHES
SLEEVE INTERIOR DIAMETER:	1 FOOT 7 INCHES
SLEEVE EXTERIOR DIAMETER:	1 FOOT 9 ½ INCHES
SLEEVE LIP ON TOP OF BOLLARD:	3 ¼ INCHES WIDE BY 1-INCH THICK
BOLLARD SLEEVE STEM LENGTH:	6 INCHES (LOCATED ON BOTTOM OF SLEEVE)
BOLLARD SLEEVE STEM EXT. DIAMETER:	4 ½ INCHES
BOLLARD HOLE COVER EXT. CIRC.:	2 FEETT 4 INCHES
BOLLARD HOLE COVER THICKNESS:	1 ¼ INCHES
BOLLARD COVER KNOTCH:	1 ¼ INCHES WIDE (USED TO INSERT METAL ROD FOR REMOVAL)

BOLLARD SHROUD (TOP PIECE)

FIRST RING EXTERIOR DIAMETER:	3 FEET 2 INCHES
SECOND RING EXTERIOR DIAMETER:	2 FEET 8 INCHES
THIRD RING EXTERIOR DIAMETER:	2 FEET 4 ½ INCHES
FIRST RING INTERIOR DIAMETER:	2 FEET 4 ½ INCHES
SECOND RING INTERIOR DIAMETER:	2 FEET 1 INCHE
SHROUD DEPTH:	2 ½ INCHES



THE BELOW ILLUSTRATION IS FOR STANDARD BOLLARDS
SEE THE 2010 MODIFICATIONS ON PAGE 1 FOR SPECIFICATIONS FOR MEDIUM WEIGHT
BOLLARDS

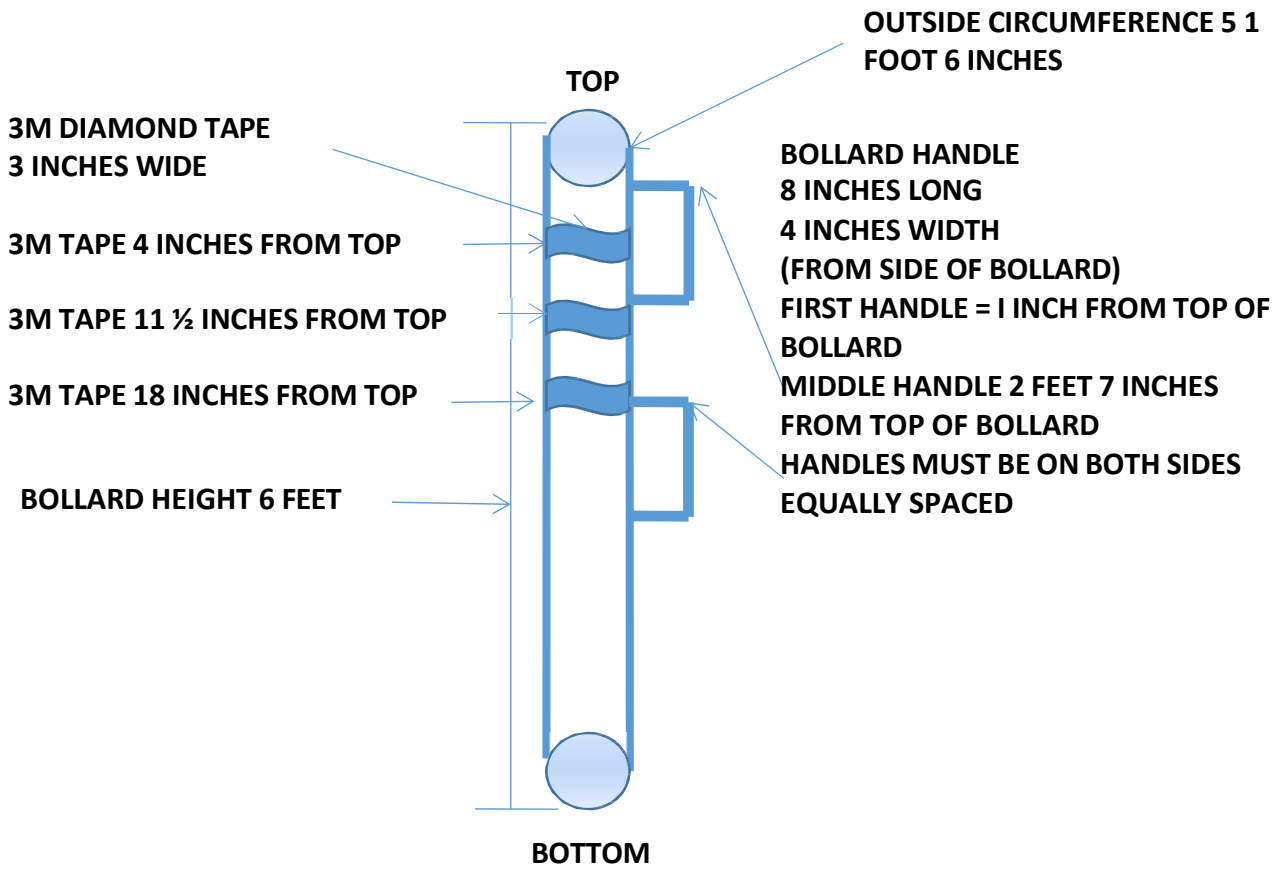





 US Army Corps of Engineers	Request for Information Report (RFI)		RFI NO. RFI-0096	PAGE NO. Page 2 of 2
	CONTRACT NO. W9127820C0020 NA K5005315	CONTRACT TITLE GROC Facility & TROC Facility	PRIME CONTRACTOR Speegle Construction, Inc	

Contractor's Request for Information			
REQUESTED BY Speegle Construction	DATE REQUESTED September 29, 2022		POTENTIAL COST IMPACT No POTENTIAL SCHEDULE IMPACT No
RFI SUBJECT	Removable Bollards		
SPECIFICATION SECTIONS	05 50 13		
DRAWINGS	CS501		
SUBCONTRACTOR			
Information Requested			
Detail calls for removable bollard 5 galv. steel pipe schedule 10 with dimensions 6" above grade and 3' below grade but not to exceed 50lbs. With the requirements being met it exceeds the weight limit resulting in difficulty for one personnel to move bollard in/out of storage hole.			
Contractor Recommendation			
SCI recommends cutting 30" bringing the height size 6' 5" to accommodate more control for one person to move bollard to and from storage hole.			
Contractor Attachments			
Government Response			
ANSWERED BY TITLE Chris E. Brockmeier, PE	DATE RECEIVED	DATE ANSWERED October 25, 2022	
Government Response to Contractor			
COR/ACO has not approved this government response.,			
Government Attachments			
<p>Stantec reviewed UFC 4-022-02 and the notes from the discussion held between the Base Engineer and the Eglin AFB Security Team/Stephen Carrico. A maximum weight of 50 lbs is recommended for the removable bollards. This maximum weight will satisfy criteria for the Eglin AFB Security Team and the Fire Chief for the bollards to be manually lifted. In addition, please refer to attached detail to this RFI for revised dimensions.</p> <p>Chris E. Brockmeier, PE Stantec Consulting Services, Inc. Civil - EOR 850-878-5001 25-October-2022</p>			

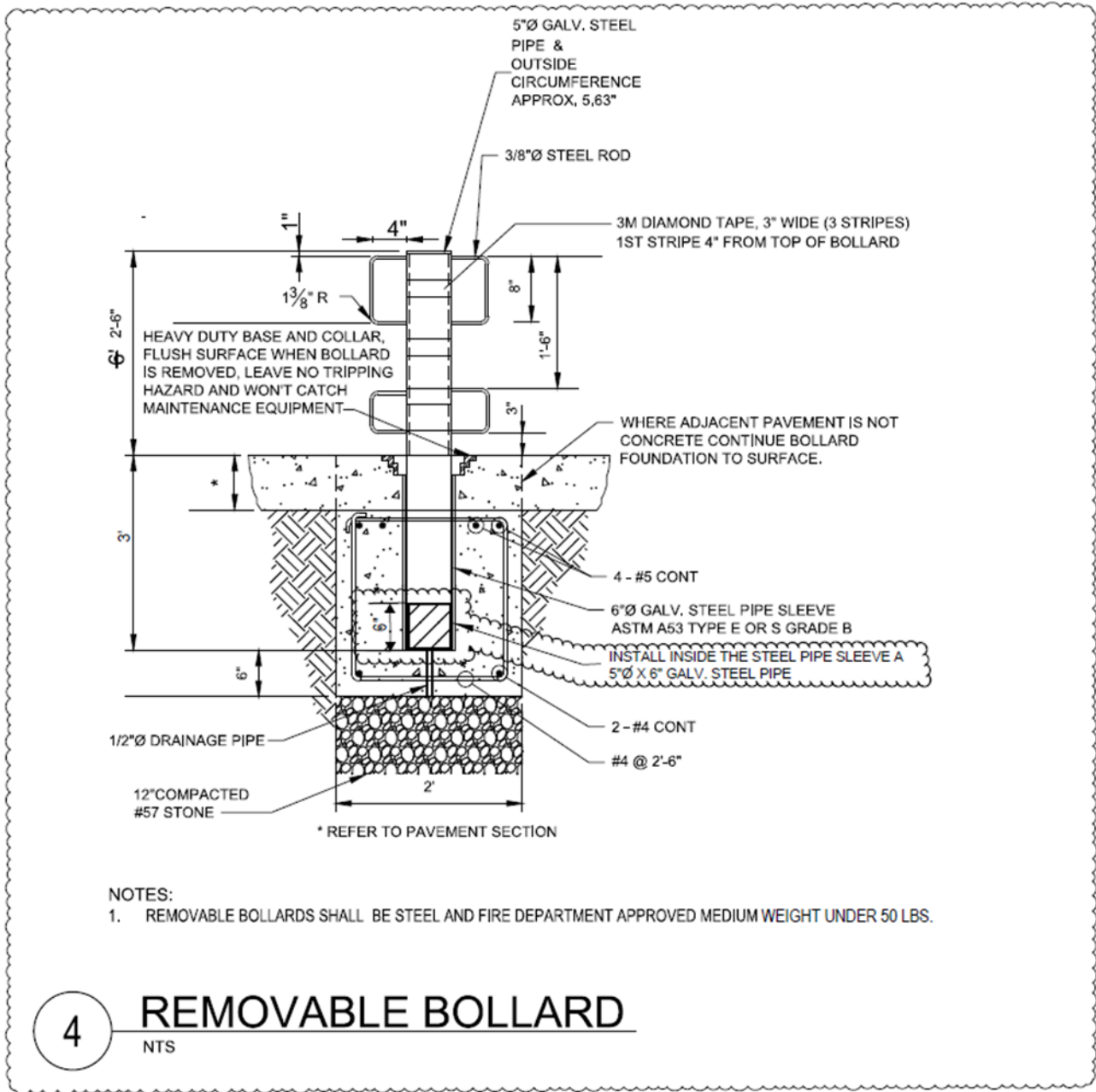

Appendix 19 – Eglin Energy Resiliency



DEPARTMENT OF THE AIR FORCE
HEADQUARTERS 96TH TEST WING (AFMC)
EGLIN AIR FORCE BASE FLORIDA



OCT 11 2017

MEMORANDUM FOR TEAM EGLIN

FROM: 96 TW/CC

SUBJECT: Eglin Energy Conservation Policy

1. Energy conservation and resilience is a critical element of our Air Force strategy. I solicit Team Eglin's support to conserve this vital resource when possible by implementing the attached energy policy that will help enable the Air Force Energy Program Vision of "Enhance Mission Assurance Through Energy Assurance."
2. Various Presidential Executive Orders and Acts of Congress mandate our Federal energy goals, which require agencies to reduce energy consumption per square foot of facilities (energy intensity) by 2.5 percent annually through Fiscal Year 2025 (FY25) and reduce water consumption intensity by 2 percent annually through FY25. One of the key elements in a successful energy conservation program is to develop and sustain a culture of awareness and individual stewardship. Every member of Team Eglin must embrace a culture of conservation and seek innovative ways to conserve and reduce energy consumption. Our collective awareness and stewardship will make a dramatic difference in Eglin's energy consumption, since the cheapest and cleanest power is the power we do not use.
3. The attachment institutes base policy and initiatives that shall be implemented by all, when applicable, in the course of their daily actions to conserve energy and resources. This policy does not cover every possible conservation scenario; therefore, I ask all commanders and equivalent leaders to implement this policy and review your internal processes to identify additional conservation opportunities. To assist you, Eglin's Energy Management team within the 96th Civil Engineer Group (96 CEG) is available upon request.
4. Together, Team Eglin can "Enhance Mission Assurance Through Energy Assurance." For further information or assistance regarding this policy, please contact the 96 CEG Energy Management team, represented by Mr. Daniel Nocher, 96 CEG/CENPE, 882-1510, daniel.nocher.1@us.af.mil.

EVAN C. DERTIEN
Brigadier General, USAF
Commander

Attachment:
Energy Conservation Policy

Attachment 3: Set Point/Setback Temperatures

HVAC control systems will be set to maintain space temperatures not to exceed the conditions in Table 1 during occupied and unoccupied hours.

Table 1: Maximum Heating and Minimum Cooling Temperatures

Occupancy	Heating Max Temp (deg F)		Cooling Min Temp (deg F)	
	Occupied	Unoccupied	Occupied	Unoccupied
Administrative areas*	68	55	74	80
NAF retail space	68	55	74	80
Community Areas such as theaters, youth facilities, etc.	68	55	74	80
Warehouse**	60	55	80	80
Shop Space**	65	55	76	80

*Administrative areas include all facilities with administrative space. Any admin space collocated with mission equipment defaults to the temperature and humidity requirements of the equipment.

**Where eligible for Air Conditioning.

Appendix 20 – Eglin Specific Termiticide Information

A20.1 Documentation Process



DEPARTMENT OF THE AIR FORCE
AIR FORCE CIVIL ENGINEER CENTER
TYNDALL AIR FORCE BASE FLORIDA

NOV 24 2014

MEMORANDUM FOR SEE DISTRIBUTION

FROM: AFCEC/CO
139 Barnes Drive Suite 1
Tyndall AFB, FL 32409-5319

SUBJECT: Documentation Process for Pesticide Applicator Certification in the Integrated Pest Management Information System (IPMIS)

1. This memorandum emphasizes the requirement to record and permanently archive DoD installation pest management operations and pesticide use using the IPMIS per DoDI 4150.07, *DoD Pest Management Program, 5.4.5*. A component of pest management operations is assurance that all pesticide application on DoD installations is accomplished by certified applicators (para. 5.4.20.5). DoD certification is required for DoD pesticide applicators. State certification is mandatory for non-appropriated funded applicators (golf course) and all contract pesticide applicators, to include part-time/seasonal and "on-demand" commercial workers.
2. With the FY15 establishment of Web-IPMIS, all individual applicators are required to establish a web-based IPMIS account and maintain state certification data as certifications are renewed. Pesticide applicator certification numbers, categories, dates of currency, and source (DoD or state) are centrally documented in the tracking tool's individual account component.
2. There is no change in the certification information requirement; however, certification data storage has moved from desktop IPMIS/hardcopy to web-based IPMIS and electronic archival. MAJCOM pest management professionals will continue to review and approve contracts, all pesticides used by contract, and in-house pesticide applicators IAW DODI 4150.07.
3. Request MAJCOMs forward this memo to bases and CE squadrons for compliance. Please refer questions to Mr. Donald Teig, Pest Management Subject Matter Expert, DSN 523-6465, donald.teig.1@us.af.mil.

A handwritten signature in black ink that reads "Tim C. Dodge".

TIMOTHY C. DODGE, Colonel, USAF
Director, Operations Directorate

A20.2 Permittable Pesticides

As stated in an email from Mr. Armondo L. Rosales, Command Entomologist, the following applies regarding pesticide application:

As the approving official for pesticides used at Eglin AFB, I will not approve anything but termiticides containing Fipronil as the Active Ingredient and is to be applied at the label highest rate.

Years of USDA termiticide research has shown that Fipronil at the highest rate provides the longest period of protection in the southeastern United States.

v/r

Armando L. Rosales
Command Entomologist
AFCEC/COSC
129 Barnes Dr. Ste. 1
Tyndall AFB, FL 32403-5319
(850) 283-6830 DSN: 523-

Appendix 21 – Eglin Specific Airfield Criteria

A 21 Follow UFC 3-260-01 (Airfield Criteria), UFC 260-04 (Airfield Marking), UFC 3-535-01 (Airfield Lighting)